

On-site P Recovery from Waste Water – the iPHOS Process

SF-SoepenberG GmbH
29. April 2026

visit: iphos.eu

Save the Date: 4. - 7. Mai 2026
Halle: A3 Stand-Nr.: 504



Interreg
Baltic Sea Region



Co-funded by
the European Union



SF-Soepenberg GmbH

- Headoffice: Hünxe, Germany
- We develop and operate nutrient recycling concepts for industries.
- We produce fertilizers from secondary sources.
- We operate and optimize industrial wastewater treatment plants and dewater sludge.
- We have developed iPHOS.



Motivation: German legislation

Comes into force 2029:

- P-recycling is required
- There is a market for P recycling technologies

iPHOS remobilizes P from activated excess sludge

Without remobilisation struvite technologies cannot recover a significant amount of P from WWTP!

Treatment steps:

1. Remobilisation
2. Slight acidification
3. Precipitation of iron
4. Flocculation
5. P-Precipitation

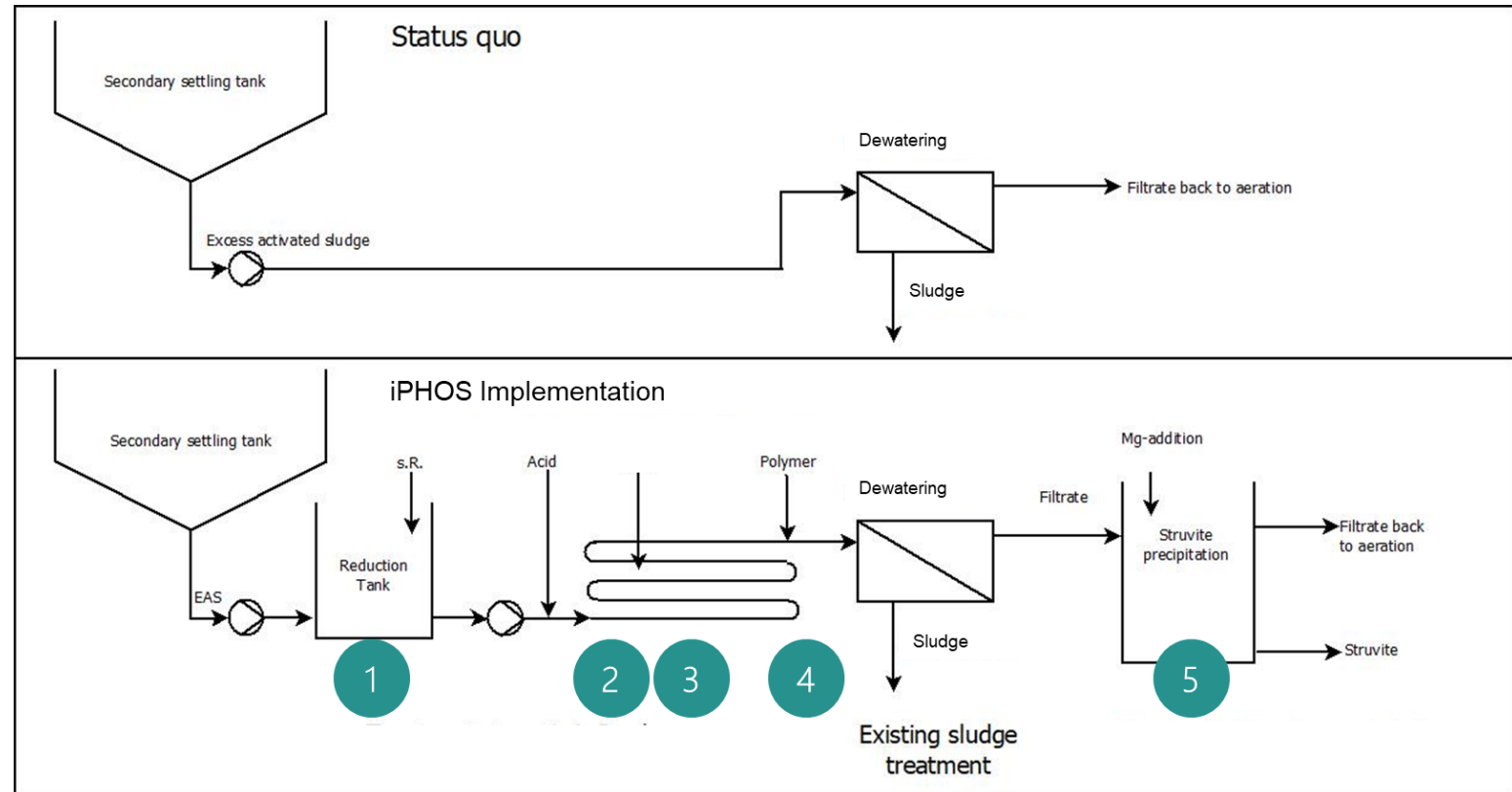

P-Remobilisation in activated excess sludge

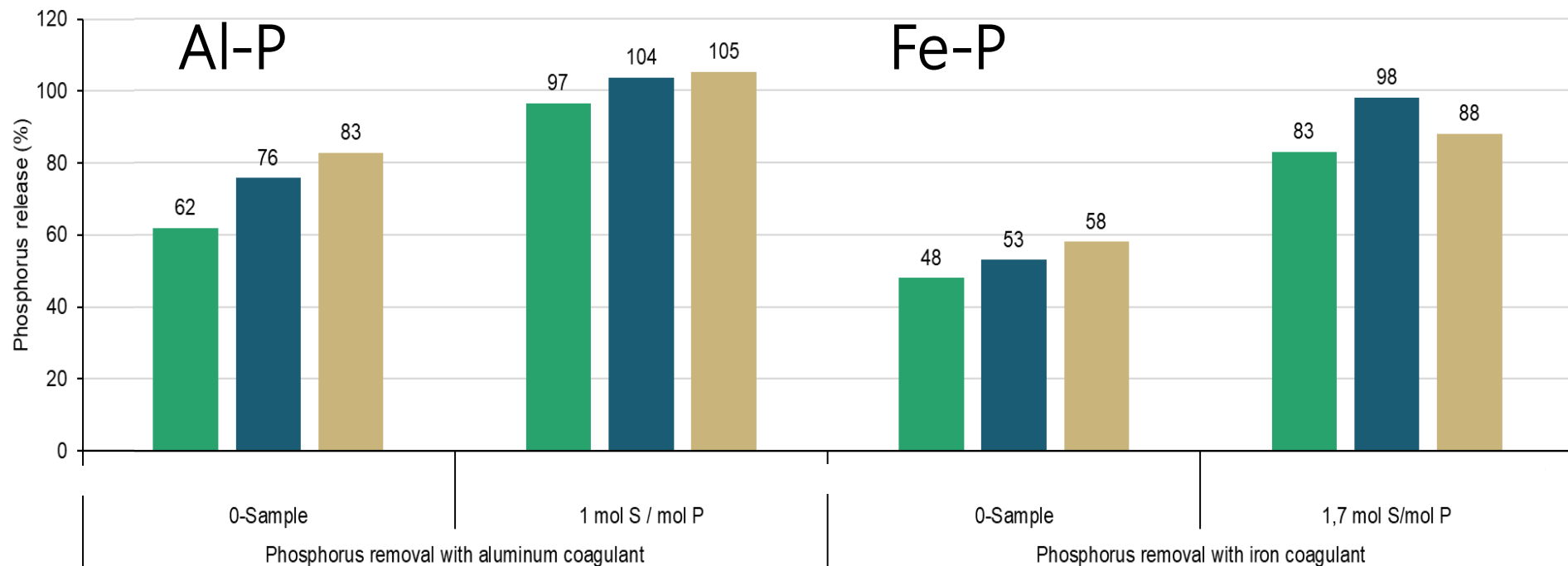
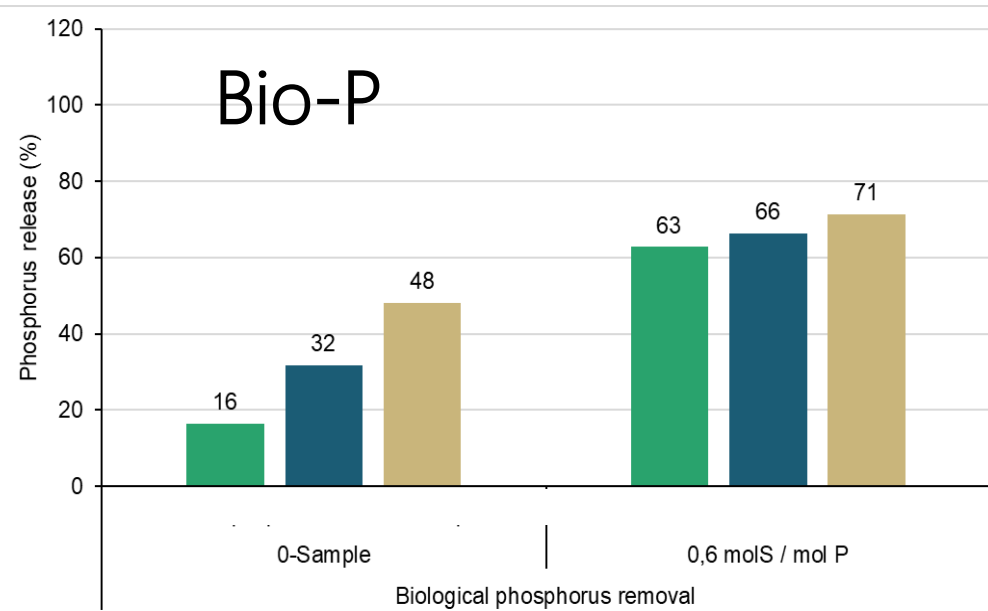

P-Remobilisation

- after 16-19 h
- after 40-42 h
- after 64-69 h

Mobile Plant

- plug & operate
- Treatment of 1 m³/h of activated excess sludge
- 2 trailers

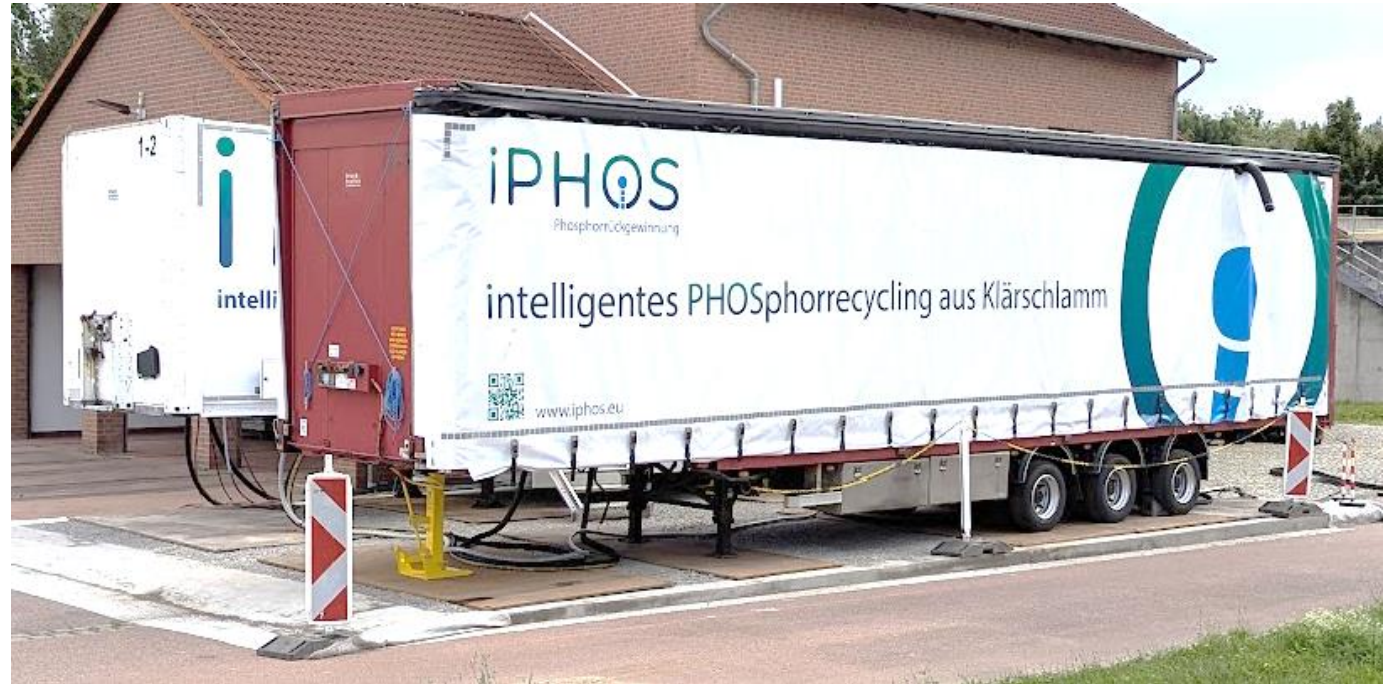

The European P-Recovery Perspective

- P recovery rates of 60% and more depending on:
 - Reduction time
 - Dosage of reducing agent
 - Temperature

Thank you for your attention
j.clemens@soepenbergl.com

iphos.eu

Save the Date: 4. - 7. Mai 2026
Halle: A3 Stand-Nr.: 504

