



Cover Delivery Report

Title of the Deliverable:	D.2.2 SYSTEMIC Business Case Evaluation Report
WP Title and Number:	WP2 Business Case Innovation
Date of completion:	25 September 2019
First Author:	Ludwig Hermann
Co-author(s):	Ralf Hermann
Name of the responsible WP Leader:	Ludwig Hermann
Date of approval by the Coordinator	

The research was undertaken as part of the project called 'SYSTEMIC: Systemic large scale eco-innovation to advance circular economy and mineral recovery from organic waste in Europe.

<https://systemicproject.eu/>

This project has received funding from the European Union's H2020 research and innovation programme under the grant agreement No: 730400. SYSTEMIC started 1 June 2017 and will continue for 4 years.



## Business Case Evaluation of six SYSTEMIC Biogas and Nutrient Recycling Plants



### Authors

Ludwig Hermann and Ralf Hermann

Proman Consulting,  
Auersthal, September 2019

Document type: Public Report

Deliverable 2.2

ISSN xxx-xxx



Horizon 2020

History of changes

Date	Version	Changes	Page
20.08.2019	Final draft	Minor clarifications	Several pages
25.09.2019	Final version		

## Content

PREFACE .....	4
SUMMARY .....	6
1 POLICY FRAMEWORK .....	9
2 LEGAL FRAMEWORK .....	11
2.1 Recast Renewable Energy Directive (RED II) 2018/2001/EU (amending Directive 2009/28/EC)	11
2.2 Energy Efficiency Directive 2018/2002/EU (amending Directive 2012/27/EU).....	12
2.3 Clean Power for Transport Directive (2014/94/EU).....	13
3 ECONOMIC FRAMEWORK.....	14
3.1 Energy flows and status of biogas .....	14
3.2 Share of biogas in the energy mix .....	15
3.2.1 <i>Biogas to power</i> .....	15
3.2.2 <i>Biogas to biomethane</i> .....	16
3.2.3 <i>Feedstock to biogas</i> .....	18
3.3 Supporting schemes and targets in Member States.....	19
3.3.1 <i>Supporting schemes</i> .....	19
3.3.2 <i>Biogas and biomethane policy objectives in EU Member States (EBA, 2018)</i> .....	21
3.3.3 <i>Transport fuel related objectives in EU Member States</i> .....	21
3.4 Barriers to biogas in EU Member States.....	23
4 BIOGAS POTENTIAL AND TRENDS IN EUROPE.....	25
4.1 EU 2050 low or net-zero carbon energy forecast scenarios (European Commission, 2018) .....	25
4.2 Biogas/biomethane potential .....	25
4.3 Conclusions from economic framework evaluation .....	36
5 BUSINESS CASE EVALUATION - APPROACH AND METHODOLOGY .....	38
6 PARTICIPATING BIOGAS PLANTS .....	39
6.1 Demonstration plants Overview .....	39
6.2 Outreach plant .....	41
7 BUSINESS CASE CHARACTERISTICS .....	42
7.1 Acqua e Sole.....	42
7.1.1 <i>Business case with NRR operational</i> .....	42
7.1.2 <i>Business case before/without NRR</i> .....	43
7.1.3 <i>Business case assessment</i> .....	43
7.2 AM-Power.....	44
7.2.1 <i>Business case with NRR operational</i> .....	44
7.2.2 <i>Business case without/before NRR</i> .....	46
7.2.3 <i>Business case assessment</i> .....	46
7.3 BENAS GmbH.....	47
7.3.1 <i>Business case with NRR operational</i> .....	47
7.3.2 <i>Business case without/before NRR</i> .....	49
7.3.3 <i>Business case assessment</i> .....	49
7.4 Groot Zevert Vergisting .....	50
7.4.1 <i>Business case with NRR operational</i> .....	50
7.4.2 <i>Business case analysis without/before NRR</i> .....	51
7.4.3 <i>Business case assessment</i> .....	52
7.5 RIKA Biofuel / Green Create W2V.....	53

7.5.1	<i>Business case analysis with NRR operational</i> .....	53
7.5.2	<i>Business Case without NRR</i> .....	54
7.5.3	<i>Business case assessment</i> .....	55
7.6	A-Farmers / Nurmon Bioenergia.....	55
7.6.1	<i>Business case analysis with NRR operational</i> .....	55
7.6.2	<i>Business Case without NRR</i> .....	56
7.6.3	<i>Business case assessment</i> .....	57
8	NUTRIENT RECYCLING POTENTIAL.....	58
8.1	Current benefits of nutrient recycling .....	58
8.2	Untapped potentials from NRR.....	58
9	BUSINESS CASE EVALUATION CONCLUSIONS.....	61
10	REFERENCES .....	63
11	ANNEX 1 BUSINESS CASE EVALUATION ACQUA E SOLE S.R.L.....	65
12	ANNEX 2 BUSINESS CASE EVALUATION AM-POWER BVBA .....	81
13	ANNEX 3 BUSINESS CASE EVALUATION BENAS GMBH .....	100
14	ANNEX 4 BUSINESS CASE EVALUATION GROOT ZEVERT VERGISTING B.V.....	122
15	ANNEX 5 BUSINESS CASE EVALUATION GREEN CREATE W2V LTD. ....	143
16	ANNEX 6 BUSINESS CASE EVALUATION A-FARMERS NURMON BIOENERGIA LTD.....	163

# Preface

This study was carried out as part of the European demonstration project SYSTEMIC funded by the H2020 Programme (project number 730400). The essence of the SYSTEMIC project are six large scale biogas plants – four in operation and two under construction - with innovative nutrient recovery and recycling techniques that are monitored and assessed by the SYSTEMIC project team regarding their overall technical, economic and environmental performances. Evaluating the business cases is one of the key tasks within the project.

Evaluating SYSTEMIC business cases has been quite a challenging task – entrepreneurs usually don't let somebody review their books except tax consultants. Nonetheless the authors managed to get a deep insight into the businesses of all five demonstration plants and one outreach plant – the beneficiaries of SYSTEMIC. Two more outreach plants were tentatively assessed but in one case the team got stuck while collecting the data and in another case the evaluation was finished but no consent was given to publish the result. The fact that not all assessments could be reported had no influence on the quality and robustness of the overall evaluation. It just shows that without a project like SYSTEMIC with several large-scale biogas plants as partners, an evaluation of business cases would not be possible.

The working thesis of SYSTEMIC is that biogas plants can serve as technology hubs for nutrient recycling, providing a concentrated flow of nutrient rich organic substrate and skilled personnel. The accumulation of aqueous residues after the reactor frequently causes elevated costs and environmental problems, particularly where no more nutrients are needed like in Flanders, the Netherlands and other regions with high livestock density. The concentrated flows through a biogas plant offer an opportunity for combining the need for removing nutrients from the region with recycling them to products that can be transported and used where needed.

To prove the working thesis, three questions needed an answer:

- (1) How relevant is biogas in the energy mix, now and in future energy scenarios?
- (2) Are the proposed technologies mature and performing as designed?
- (3) Are integrated business cases, biogas & nutrient recycling commercially viable – do investments generate a reasonable return in due time?

Question (1) may be perceived of low relevance while evaluating established business cases, at least if going beyond current energy flows, supply and consumption statistics. Yet, the SYSTEMIC team had been asked by the project officer to assess the accessibility of biogas businesses to ESIF (European Structural and Investment Funds) funding, providing, among others, 450 M€ for sustainable, rural development. None of the covered EU Member States has opened ESIF funding to biogas. As a potential alternative, the European Investment Bank (EIB) was approached and three bankable biogas & nutrient recycling investment projects with a total CAPEX of about 100 M€ were proposed for EIB loan co-financing. After promising early-stage discussions at high level, one of the experts later involved was ill-disposed to anaerobic digestion. Consequently, no EIB finance is available for projects following the SYSTEMIC role model. The ESIF/EIB experience, downgrading supporting schemes in some EU Member States and the low profile of biogas in the public climate debate motivated the team to more thoroughly investigate the present and potential future roles of biogas/biomethane in the EU-2050 low or net zero carbon emission energy mix. The partly surprising result: biogas, upgraded to biomethane and e-gas is assigned a relevant share (7-10%) in the renewable energy supply in all eight EU scenarios and an even higher share by private studies. Hence, the authors thoroughly reviewed the most important studies on strategic energy options and provide a biogas related résumé in this study. It includes an update to the EU policy and regulatory framework, particularly addressing the ambitious EU-2050 long-term (energy) strategy and the related updates of the Renewable Energy Directive and the Energy Efficiency Directive.

Question (2) is mainly addressed by other work packages. Nonetheless, the business case assessments provide robust evidence that well-conceived and professionally operated nutrient recycling processes work properly – otherwise they would have a negative impact on the P&L account.

Question (3) was assessed by several rounds of questions and answers in face-to-face meetings, phone conversations and by mail exchange. Participants were convinced that to open the books is in their own

Question (3) was assessed by several rounds of questions and answers in face-to-face meetings, phone conversations and by mail exchange. Participants were convinced that to open the books is in their own interest. In addition, there is nothing to hide since SYSTEMIC business cases are real success stories. Most business cases are highly profitable, offer qualified jobs in rural regions and contribute to reduce greenhouse gas emissions, particularly if they use manure and poultry litter.

Not everything is perfect yet. Businesses can still generate more profit by upcycling and marketing the products to markets where specific properties are in demand. Yet, this is only marginally covered in this study and will be extensively covered by corresponding tasks in the remaining twenty months of the SYSTEMIC project.

The authors owe to the highly committed practitioners and scientists of the SYSTEMIC team, particularly to the owners and operators of demonstration and outreach plants, highly relevant facts and insights to surprisingly innovative businesses that can serve as a role model for a fossil free energy future with bio-methane and recycled nutrients effectively contributing to a sustainable, material efficient, low-emission, Circular economy.

25.09.2019

A handwritten signature in blue ink, appearing to be 'LH' followed by a stylized flourish.

Ludwig Hermann

A handwritten signature in blue ink, appearing to be 'Ralf Hermann' in a cursive style.

Ralf Hermann

More information on the SYSTEMIC business cases can be found in the report on "*Development and application of economic key performance indicators*" published by Wageningen Environmental Research, Wageningen, September 2019.

This research and publication were undertaken as part of the project called 'SYSTEMIC: Systemic large scale eco-innovation to advance circular economy and mineral recovery from organic waste in Europe'. This project has received funding from the European Union's H2020 research and innovation programme under the grant agreement No: 730400.



# Summary

The SYSTEMIC Business Case Evaluation Report addresses the current policy, legal and economic frameworks in the European Union and six individual biogas plant business cases in EU Member States operating in different environments governed by national policies, traditions and corresponding agricultural and food industry activities.

Since biogas (anaerobic digestion) businesses are largely driven by national support schemes, the first critical question to respond was if current and future investors can expect a policy and legal framework providing (continuous or higher) support to conversion of organic (agricultural, domestic and industry) waste and fresh plant material (energy crops) to biogas and electricity, biomethane or bio-LNG/CNG. The "Clean energy for all Europeans" package, adopted 2015 and the adoption of the "2050 Long-term strategy" in November 2018, including the recasts of the Renewable Energy Directive EU 2018/2001 and the Energy Efficiency Directive EU 2018/2002, both adopted in December 2018 provide an EU policy framework and legislation that draws a consistent pathway towards a low or net zero CO<sub>2</sub> emission EU-2050 economy with an energy mix including biomass and biogas as energy carriers. The remaining risk is in national policies that would not transfer European Directives to national legislation.

After having confirmed a favourable policy and legal framework, the economic framework is addressed. Since support schemes are based on energy outputs, the importance of biogas in a low carbon energy mix is evaluated. Currently, gas contributes 245 Mtoe (Million Tons of Oil Equivalent, 10 EJ, 22%) to the final energy consumption in Europe of which 17 Mtoe (0.7 EJ, 7%) is biogas. The EU-2050 scenarios estimate a sustainable (without land-use change) biomethane supply in the order of 50-92 Mtoe, compared to a technical potential of 150 Mtoe. The transport sector (mainly heavy good vehicles) could become a relevant consumer of bio-LNG and bio-CNG. Pipeline grade biomethane and e-gas – as a conversion product of captured CO<sub>2</sub> and H<sub>2</sub> from excess electricity) together could contribute 7-10% to the 2050 energy mix and some 50% of the gas supply. The scenarios seem realistic including the availability of suitable biomass. All strategic options provide a solid growth potential for biogas plants.

The study also addresses national support schemes and barriers to achieve the estimated scenarios. In short, the design of effective support schemes and the barriers to the implementation of biogas plants are similar. Biogas will continue to need support schemes, but it must be considered that biogas is frequently provided by small and medium private enterprises (SMEs) and includes storage and transport options for continuous supply – in contrast to wind and photovoltaics. Biogas/biomethane can be used as chemical building block for carbon based, non-energetic uses and – if manure is used as feedstock – has a negative footprint of up to 100% due to saving large amounts of emissions from livestock rearing.

For the individual business case evaluations, six demonstration/outreach plants were assessed:

**Acqua e Sole S.r.l.**, a thermophilic anaerobic digestion plant in Vellezzo Bellini (30 km south of Milan), Pavia, Lombardy, Italy, in operation since 2016 with a total annual substrate processing capacity of 85,000 t. Processing municipal sewage sludge and source separated domestic food waste.

**AM-Power BVBA**, a thermophilic anaerobic digestion plant in Pittem (40 km west of Ghent), West-Flanders, Belgium, in operation since 2011 with a total annual substrate processing capacity of 180,000 t. Processing biowaste and manure.

**BENAS GmbH**, a mesophilic anaerobic digestion plant in Ottersberg (40 km east of Bremen), Lower Saxony, Germany, in operation since 2006 with a total annual substrate processing capacity of 174,000 t. Processing corn silage, plant residues and poultry litter.

**Groot Zevent Vergisting B.V.**, a mesophilic anaerobic digester plant in Beltrum (35 km southwest of Enschede), Achterhoek Region, Province Gelderland, The Netherlands, in operation since 2004 with a total annual substrate treatment capacity of 135.000 t. Processing manure and biowaste.

**Green Create W2V Ltd.**, a mesophilic anaerobic digester at Fridays' Knoxbridge Farm, Frittenden, Cranbrook, Kent, United Kingdom, currently under construction with a total annual substrate treatment capacity of 60,000 t. Planned to process poultry litter and straw.

**Nurmon Bioenergia Ltd.**, a mesophilic anaerobic digester in Seinäjoki (80 km southeast of Vaasa), South Ostrobothnia, Finland currently under construction with a total annual substrate treatment capacity of 240,000 t. Planned to process manure, industry by-products and plant biomass.

The business cases represent large-scale biogas activities owned and operated by SMEs (4-9 M€ sales) servicing the farming and food industry sector. Plants are located in high livestock density regions (Belgium, The Netherlands), in regions with moderate livestock density (Finland, Germany, UK) and low livestock density (Italy). A variety of feedstock is used including manure, poultry litter, agricultural waste, food industry waste, source separated domestic food waste and sewage sludge. By far the most important source of revenues is energy supplies paid by feed-in tariffs or feed-in premiums. In contrast to all other plants, Acqua e Sole in Italy generates most of its revenues from gate-fees for processing municipal sewage sludge.

Nutrients have a significant impact on the business cases, despite not directly contributing to revenues. Where nutrients are in oversupply due to high livestock density, the business cases are most sensitive. Without/before nutrient recovery and removal (NRR), digestate handling and disposal may eat up 38% - 58% of the revenues whereas in other regions and with NRR the equivalent cost is 0% - 16%. This is not the only drawback of a location with nutrient oversupply. A larger number of biogas plants – desirable for the energy mix and rural jobs – may lead to a shift of negotiation power between the SME service company and the industrial waste producer, leading to payments for processing organic waste. Hence, the pressure is from both sides, supply and disposal markets. Whereas Acqua e Sole receives an average gate-fee of € 63/t of organic waste, AM-Power and BENAS have to pay some 8-25 €/t. Albeit, BENAS is in a comparatively comfortable position due to using all fertilising products on cropland managed by the company. What you can learn from the evaluation is that investors should avoid coming into pressure from the supply and disposal side and NRR is of paramount importance if the plant is located in a region with nutrient oversupply.

Nutrient recycling as such is always positively contributing to the cash flows of biogas operators. In both cases where a direct comparison (before/after) is possible, NRR improves the financial results by 340,000-1.6 M€. In all other plants NRR is part of the initial design and only hypothetical contributions can be calculated – some plants would not convert the selected substrate to biogas, and some would need much larger storage facilities, increasing the cost by 500.000-1.75 M€. Doubtlessly, NRR is a meaningful strategic option to large-scale biogas plants and returns are particularly interesting if the cost of handling and disposing the untreated digestate is high. Apart from costs driven by nutrient oversupply in the region, costs can be high due to restrictions in applying nutrients because of climatic constraints or designated nitrate vulnerable zones according to the Nitrates Directive.

An untapped potential for improving the business cases lies in the upgrading of products from NRR. Currently, none of the plants reports relevant revenues from the recycled fertilising products. Suitable market potentials have only marginally been studied. The focus was on finding technical solutions and on saving costs for handling and disposal. A few potentials have been revealed, bio-degradable pots from the FiberPlus system in Germany and potting soils from the solid digestate fraction in the Netherlands and the UK. However, negotiations are at an initial stage and potential returns cannot be calculated yet. Role models from solution providers in Canada and the US show that product could be sold at much higher prices to determined markets like the gardening or turf markets, if specific properties could be marketed as unique selling propositions. Examples are laid out in the chapter dealing with nutrient recycling potentials.

Nutrient recovery and recycling (NRR) doubtlessly has a positive impact on the P&L account of the evaluated cases and will have the same effect in all cases where some restrictions apply to the use of digestate in the vicinity of anaerobic digestion plants and – of course – if certain quantity thresholds are achieved that generate revenues which can pay-back the investments. Such biogas businesses will generate relevant returns from cost savings, even without explicitly marketing the recycled products to higher end markets. However, much better results may be achieved if markets can be found/developed where the products are in demand. For this purpose, unique selling propositions must be emphasized, i.e. product properties that stand out from the crowd in certain markets. This task should be performed

during the remaining project life by developing the investigations and negotiations with interested parties.

#### **Recommendations to the team**

- Screen (niche) and specific markets (e.g. garden, bio-stimulants, soil, turf, etc.) for promising opportunities
- Screen product properties if in compliance with the requirements of the identified market opportunity
- Provide evidence for the claimed product properties (tests by independent science institutes) and emphasize these properties in the publications
- Determine the total addressable market (TAM) and the serviceable addressable market (SAM) and the total obtainable market (SOM), considering the relation between supply potential and demand of customers. If the demand of one single customer is by orders of magnitude larger than the supply potential, interest may be low.
- Identify target customers and find out the needs of these target customers
- If you find some consensus, adapt the product and start tests with the customer

#### **Policy recommendations**

The EU Policy Framework is largely in conformity with the recommendations of the SYSTEMIC Report on regulations governing AD and NRR in EU member states. However, the European objectives need to be transferred to national legislation – by 30 June 2020 RED II and the Energy Efficiency Directive should be adopted by Member State legislation. SYSTEMIC participants and board members should continuously monitor if this happens and take action, if national governments do not act.

# 1 Policy Framework

The Paris Agreement, adopted by virtually all 195 United Nations in September 2015 (UNFCCC, 2015), sets the frame for global energy policies aiming at keeping global warming “well below 2° C”. The EU, emitting 3472 Mio t CO<sub>2</sub> and responsible for 10.4% of global greenhouse gas emissions, has adopted, within the “Clean energy for all Europeans package” (European Commission, 2017), in November 2018 a strategic long-term vision for a prosperous, modern, competitive and climate-neutral economy by 2050 – A Clean Planet for All (European Commission, Press Release Database, 2018). In December 2018 a recast of the Renewable Energy Directive (Directive 2018/2001/EU) and a recast of the Energy Efficiency Directive (Directive 2018/2002/EU) aiming to increase renewable energy to at least 32% of the EU’s accumulated energy consumption and to improve energy efficiency by at least 32.5% by 2030 were adopted. In addition, by 2030 a minimum of 14% of the energy (fuel) consumed in road and rail transport must be supplied from renewable energy sources (European Union, 2018). The EU climate and energy policies combined are expected to reduce greenhouse gas emissions by 45% by 2030.

Full compliance with the Paris Agreement would require the EU to achieve greenhouse gas emissions neutrality by 2050. The transition towards a net-zero greenhouse gas economy gives energy a central role as it is today responsible for more than 75% of the EU’s greenhouse gas emissions. Imports of fossil fuels are expected to fall to 20% by 2050 cumulatively saving € 2-3 trillion from 2031-2050.

Since an emission peak in 1979, Europeans have managed to decouple greenhouse gas emissions from economic growth: between 1990 and 2016, energy use was reduced by almost 2% and greenhouse gas emissions by 22% while GDP grew by 54% (European Commission, COM(2018) 773 final, 2018). The share of renewable energy in final energy consumption increased from 9% in 2005 to 17% today. The more or less ambitious scenarios of total energy consumption and energy mix by 2050 are shown in figure 1.1. For comparison with energy consumption figures in this and in other studies: 1639 Mtoe (megaton of oil equivalent) corresponds to 68.6 EJ (Exajoule, 10<sup>18</sup> Joule) and 1192 Mtoe to 49.9 EJ.

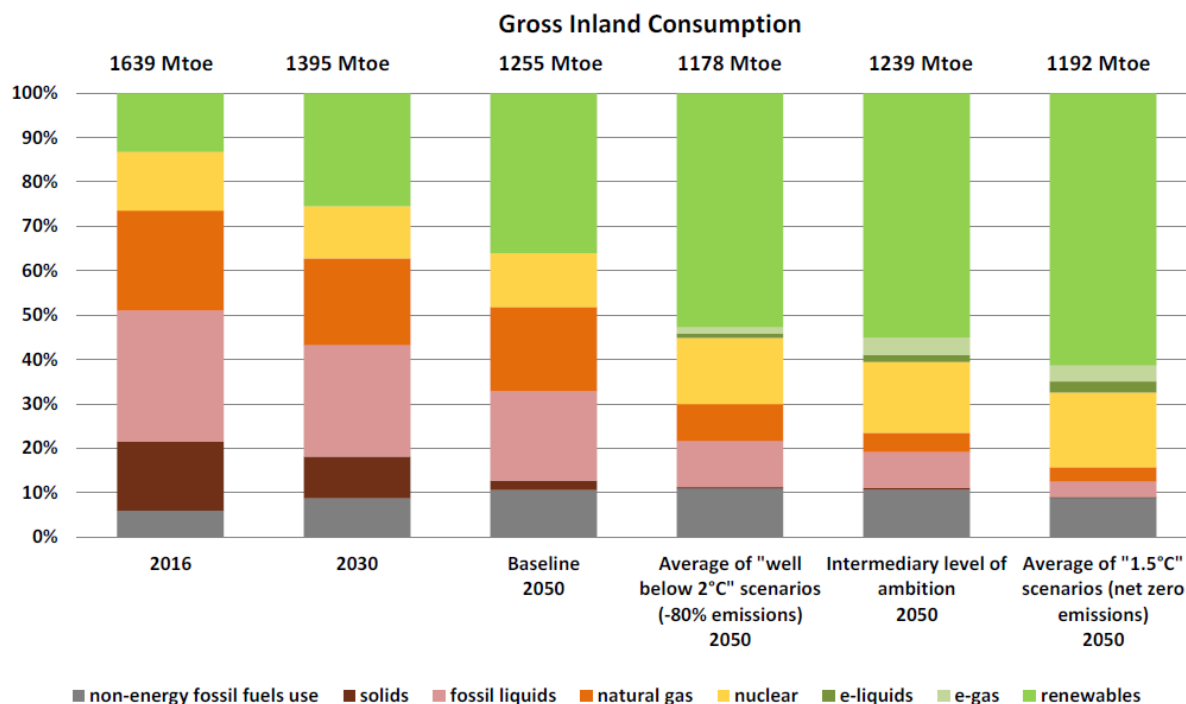

Figure 1.1 Current, 2030 and more or less ambitious 2050 energy consumption and mix scenarios (European Commission, 2018)

The 2050 scenarios correspond to reducing the total energy consumption by c. 30% and covering more than 50% of the remaining energy use by renewables – indeed an ambitious target, also requiring up to 80% higher biomass use compared to 2018.

Biomass can directly supply heat, can be converted to biofuels and to biogas, which after purification and conversion to biomethane, can substitute natural gas and make full use of the existing infrastructure. If biogas is converted to biomethane CO<sub>2</sub> can be used or stored creating negative emissions. Liquefied or compressed natural gas with high blends of biomethane could also be a short-term alternative for long-distance, heavy duty vehicles, a pathway pursued by several Member States (European Commission, 2018).

Methane and nitrous oxide emissions from agriculture currently make up 10-12% of anthropogenic greenhouse gas emissions (Frank, et al., 2018). Precision farming and higher efficiency in fertiliser and plant protection products as well as treatment of manure and agricultural residues in anaerobic digesters have a high potential to reduce greenhouse gas emissions. Farmers, foresters and rural entrepreneurs can find new business opportunities through the circular bioeconomy. Better farming practices can play a double beneficial role in reducing emissions and providing effective carbon sinks in soils and plants (European Commission, 2018).

De-carbonising the EU economy will require significant additional investment, in the order of c. € 520-575 billion per year, up from current € 175-290 billion. Both, European Commission and IPCC agree on the need of annual investments in the energy system in the order of 2.5-2.8% of GDP (European Commission, 2018) (Masson-Delmotte, et al., 2018).

Socially fair environmental taxation, carbon pricing systems and revised subsidy structures are amongst the most efficient tools for environmental policy. Taxes and carbon pricing should be employed to account for negative environmental impacts and focus on increasing energy efficiency, reducing greenhouse gas emissions and enhancing the circular economy. New sources of funding will have to be explored, for example a consistent application of the 'polluter-pays' principles and the phasing out of existing fossil fuel subsidies (European Commission, 2018).

Even under the most ambitious scenario, the EU economy is expected to more than double by 2050 compared to 1990. A trajectory compatible with net-zero greenhouse gas emissions, together with a coherent enabling framework, is expected to have a moderate to positive impact on GDP with estimated benefits of up to 2% of GDP by 2050 and a continuous growth of jobs compared to the baseline (European Commission, 2018).

An EU-wide informed debate should allow the EU to adopt and submit an ambitious strategy by early 2020 to the UNFCCC as requested under the Paris Agreement (UNFCCC, 2015). Apart from the internal strategies, close cooperation with all parties to the Paris Agreement should facilitate a long-term mid-century strategy to be determined 2020 in response to the recent IPCC Special Report on 1.5°C maximum warming (Masson-Delmotte, et al., 2018).

The policy framework does not focus on SYSTEMIC activities but it has all necessary elements to positively accommodate sustainable conversion of agricultural and industrial organic residues to biogas, power and biomethane. Conversion of organic residues to energy will remain the driver for anaerobic digestion and enabler of nutrient recovery and recycling within a circular economy framework.

## 2 Legal Framework

As to the overall legal European and Member States framework relevant to SYSTEMIC demonstration and outreach plants, we refer to the SYSTEMIC Deliverable 2.1 Report on regulations governing Anaerobic Digestion (AD) and Nutrient Recovery and Recycling (NRR) in EU Member States.

This report provides policy recommendations that have been largely included in the recent recast of the Renewable Energy Directive (2018/2001/EU) and the Energy Efficiency Directive (2018/2002/EU) which are part of the Clean Energy for All Europeans package and entered into force in December 2018. Since both Directives are highly relevant for the SYSTEMIC business cases and were adopted after the publication of the mentioned report a summary is provided here.

With regard to the use of liquid or compressed biomethane that may become important for some of the SYSTEMIC business cases, including Acqua e Sole, Nurmon Bioenergia (Atria Farmers) and Rika Biofuels (Green Create W2V), a short description of the Clean Power for Transport Directive (2014/94/EU) is also provided (European Union, 2014).

### 2.1 Recast Renewable Energy Directive (RED II) 2018/2001/EU (amending Directive 2009/28/EC)

The RED II Directive (European Union, 2018), enforced on 11 December 2018 and requiring transposition into national regulation by 30 June 2021, aims to provide new, comprehensive rules on energy regulation for the next decade.

#### **The directive includes:**

- A binding EU overall target for 2030 of at least 32% of energy from renewable sources;
- Rules for cost-effective and market-based financial support for electricity from renewable sources;
- Protection of support schemes from modifications which put existing projects at risk;
- Cooperation mechanisms between EU countries, and between EU countries and non-EU countries;
- Simplification of administrative procedures for renewables projects (including one-stop-shops, time-limits, and digitalisation);
- An improved guarantee of origin system, extended to all renewables;
- Rules allowing consumers to produce their own electricity, individually or as part of renewable energy communities, without undue restrictions;

#### **In the heating and cooling sector:**

- An annual increase of 1.3 percentage points in the share of renewable energy in the sector
- The right for consumers to disconnect from inefficient district heating and cooling systems and
- Third-party access for suppliers of renewables and waste heat and cooling to district heating and cooling networks;

#### **In the transport sector:**

- A binding target of 14% with
- A specific sub-target for advanced biofuels of 3.5% and
- Caps on conventional biofuels and on high indirect land use change risk biofuels;

## Providing

- A stable, market-oriented European approach to renewable electricity;
- Long-term certainty for investors
- Speeds up procedures for permits to build projects;
- The right to consumers to take part in the energy transition with the right to produce their own renewable energy;
- The increased use of renewables in the heating and cooling and the transport sectors;
- EU sustainability criteria for bioenergy;
- The EU's binding target to be achieved cost-effectively.

Providing a harmonised European regulative framework, the RED II Directive will hopefully enable large-scale take up of renewable gas in the next decade. It will facilitate access for biomethane to the natural gas grid, extend guarantees of origin from renewable electricity to renewable gas and make the cross-border trade of biomethane easier.

The new sustainability policy will further regulate the production of biogas and biomethane by introducing sustainability thresholds for all energy sectors. Biogas and biomethane must reach 65%-80% greenhouse gas savings depending on the sector when set against the fossil fuel comparators. Sustainable feedstock types are listed in Annex IX. Annex VI determines the default emission values for different pathways. The Annexes are kept under continuous review. RED II includes a delegated act about high and low "Land use, land-use change and forestry (LULUCF)" risk energy feedstock that is supposed to lead to amendments in the Member States' regulations regarding supported feedstock.

The positive role of biomethane in both compressed and liquid form, particularly in a heavy-duty vehicle sector that is challenging to de-fossilise, is acknowledged by most EU regulations, from the Directive on Alternative Fuels Infrastructure to the Renewable Energy Directive. The third Clean Mobility Package, published in May, puts forward the first ever CO<sub>2</sub> emissions standards for heavy-duty vehicles. The tailpipe approach adopted by the new Regulation is, however, unfavourable to gas vehicles.

## 2.2 Energy Efficiency Directive 2018/2002/EU (amending Directive 2012/27/EU)

The main amendments of the 2018 Energy Efficiency (European Union, 2018) in comparison to the 2012 Directive include:

- A 32.5% energy efficiency target (instead of 20% in the previous Directive) by 2030 and anticipating further improvements after that;
- Removing barriers in the energy market that obstruct efficiency in the supply and use of energy;
- EU countries to set their own national contributions for 2020 and 2030;
- From 2020, EU countries will require utility companies to help their consumers use 0.8% less energy each year (for Malta and Cyprus 0.24%), which will attract private investment and support new competitors in the market;
- Clearer rules on energy metering and billing, strengthening consumer rights, in particular for people living in multi-apartment buildings;
- EU countries must have transparent, publicly available national rules on the allocation of the cost of heating, cooling and hot water services in multi-apartment and multi-purpose buildings where these services are shared;
- Strengthening social aspects of energy efficiency by taking energy poverty into account in designing energy efficiency schemes and alternative measures.

The Energy Efficiency Directive may be relevant to the SYSTEMIC business cases with regard to driving co-generation of heat and power and it may have impacts to the Member States' regulations regarding energy supply of biogas plants. It has been adopted since 24 December 2018 and mostly has to become law in the EU countries by 25 June 2020.

## 2.3 Clean Power for Transport Directive (2014/94/EU)

The Directive 2014/94/EU

- establishes standard rules on rolling out the EU's alternative fuels infrastructure (i.e. electric car recharging stations or natural gas refuelling points) in the different EU countries and
- lays down minimum requirements for building up this infrastructure, to be implemented as part of every EU country's national policy framework.

### KEY POINTS

- EU countries must adopt national policies that aim to develop the market for alternative transport fuels and the infrastructure to support them. In drawing up these policies, EU countries must:
  - Make an assessment of the current state of the market and prospects for future development;
  - Set national targets for deploying the infrastructure and the measures necessary to meet them;
  - Designate networks for this infrastructure.

Countries must provide the following, by the following dates.

- 2020 — sufficient recharging stations to allow electric cars to travel around densely populated areas within the network the country has determined.
- 2025 (end) — sufficient recharging stations for hydrogen (for any country that decides to include hydrogen in its national policy framework).
- 2025 (end) — sufficient liquefied natural gas (LNG) stations at seaports, to accommodate LNG-powered ships.

EU Member States are required to submit a progress report to the European Commission on the implementation of their national frameworks by 2019, and every 3 years after that.

LNG fuelling stations include infrastructure facilities for blends of LNG and liquid biomethane and national targets may cover liquid or compressed biomethane for use as transport fuel.



# 3 Economic Framework

## 3.1 Energy flows and status of biogas

One critical question in evaluating business cases is if the contribution of biogas plants to the European energy mix is relevant and if this relevance continues to exist in future European energy mix scenarios. To facilitate a judgement to the reader, the key European current and projected energy flows are laid out in this chapter. They are mainly based on the most recent publications by Eurostat (European Union, 2018) and the In-depth analysis in support of the Commission Communication COM2018 773 A clean planet for all (European Commission, 2018).

The gross EU inland energy consumption in 2016 was 1641 Mtoe or 68.7 EJ representing c. 8.5% of the gross global energy consumption of 19269 Mtoe (<https://www.iea.org/sankey/>) or 806.8 EJ. According to the Clean Energy for all Europeans package (European Commission, 2017), by 2030 the consumption should go down to 1395 Mtoe (58.4 EJ) to achieve 1192 Mtoe (49.9 EJ) in a net-zero emission scenario in 2050 that is one of eight scenarios conceived in a comprehensive scenario study in preparation of the “Clean Planet for All Europeans” package (European Commission, 2018).

The 2016 final energy consumption (after self-consumption in the energy sector, transformation and distribution losses) was 1108 Mtoe (46.4 EJ) to which petroleum and products contributed 437 Mtoe (18.3 EJ, 39.4%), gas 245 Mtoe (10.3 EJ, 22%), electricity 239 Mtoe (10.0 EJ, 21.5%), renewables 89 Mtoe (3.8 EJ, 8%), derived heat 48 Mtoe (2.0 EJ, 4.3%) and solid fuels 45 Mtoe (1.9 EJ, 4%). 98 Mtoe (4.1 EJ, 8.8%) is consumed for purposes not related to energy use, e.g. by the chemical industries. In terms of sectoral energy consumption, transport is responsible for 367 Mtoe (15.4 EJ, 31.1%), residential 285 Mtoe (11.9 EJ, 25.7%), industry 277 Mtoe (11.6 EJ, 25%), services 150 Mtoe (6.3 EJ, 13.5%), agriculture 24 Mtoe (1.0 EJ, 2.2%) and fishing 1.4 Mtoe (0,06 EJ). The final energy consumption flows by sector are visualised in figure 3.1 below.

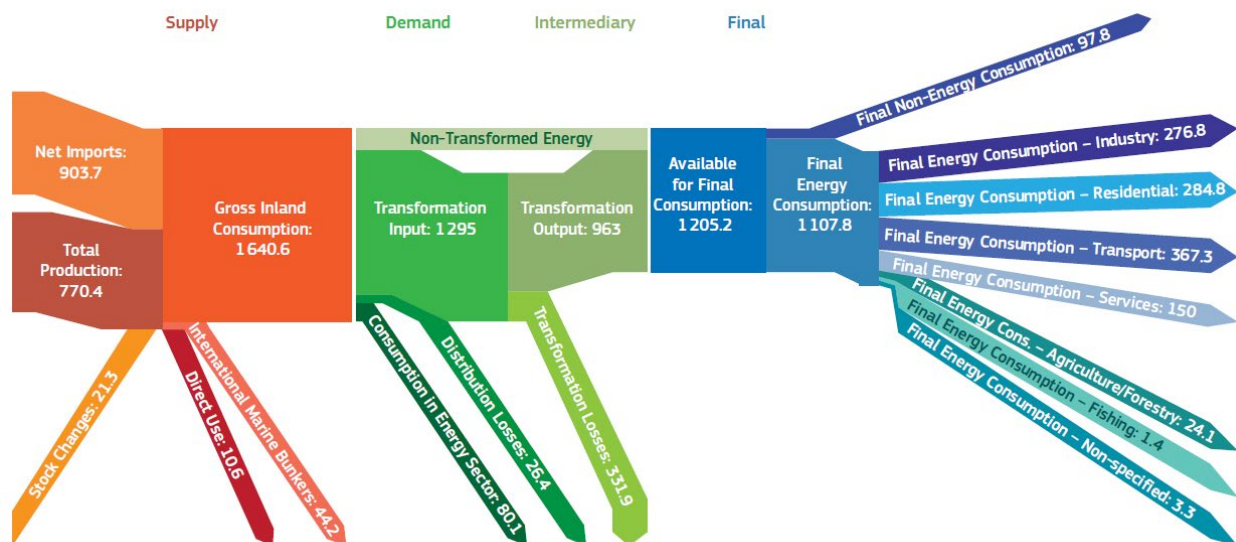

Figure 3.1 EU Energy Flow 2016 (Source Eurostat May 2018)

The installed electricity capacity (IEC) is 991 GW. Combustible fuels contribute 46%, hydro 16%, wind 16%, nuclear 12% and solar 10% to the IEC. The total installed renewable electricity capacity is 412 GW (42%). Total electricity supply is 3255 TWh (280 Mtoe) to which renewable energy carriers contribute 982 TWh (84 Mtoe) or 30%, up from 12.6% in 1990. The breakdown of renewable energy sources is shown in figure 3.2.

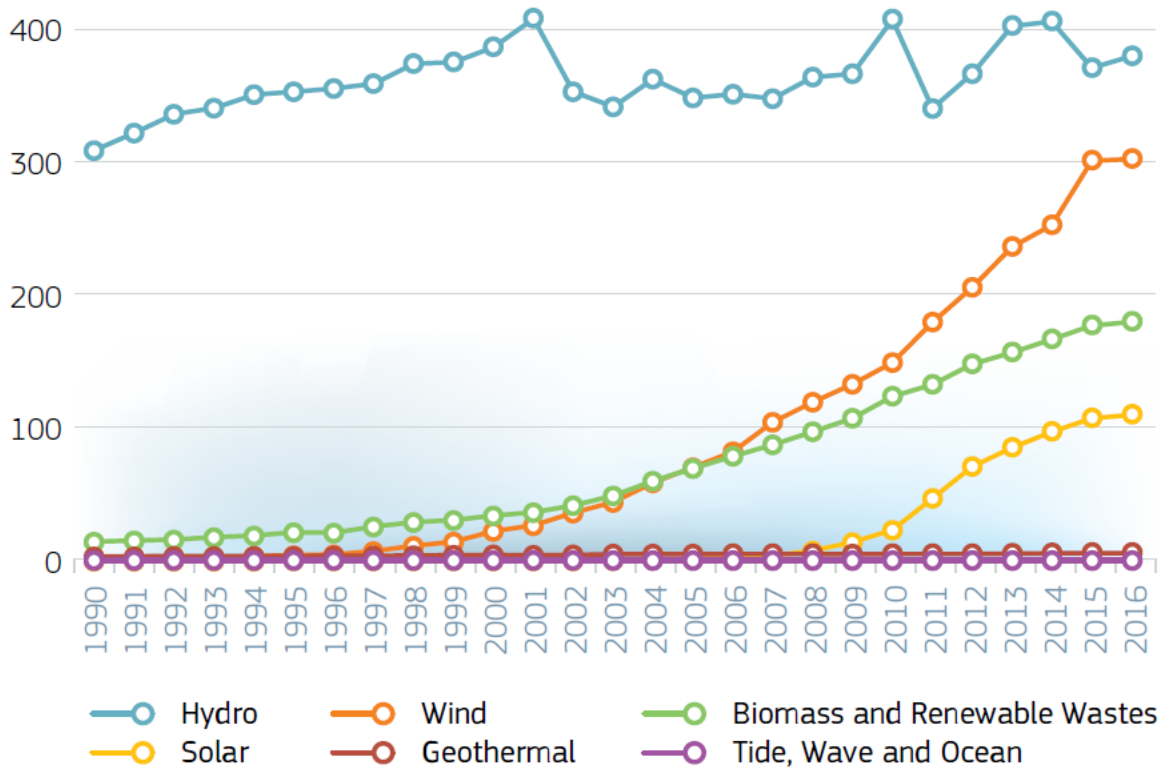

Figure 3.2 Gross conversion of renewables to electricity, 1990-2016, in TWh (European Union, 2018)

## 3.2 Share of biogas in the energy mix

Regardless of the unfavourable, diversified, unstable and uncertain political and legal framework in the European Member States (referred to in the “SYSTEMIC Report on Regulations governing AD”), the biogas sector continued to grow in terms of plants as well as biogas, electricity and biomethane output. By the end of 2017, the European Biogas Association (EBA) reported 17,783 biogas plants and 540 biomethane plants producing c. 17 Mtoe (0.7 EJ) biogas in the EU28, corresponding to 19% of the share of renewables and 1.5% of the total final energy consumption. The total Installed Electric Capacity (IEC) of biogas plants continued growing by 5% to reach a total of 10.5 GW and the power output reached 65.2 TWh (5.6 Mtoe), representing 6.6% of the renewable and 2% of the total European electricity supply. Biomethane output grew by 12% to 19.4 GWh or 1.94  $\text{bm}^3$  in 2017 (EBA, 2018).

### 3.2.1 Biogas to power

Electricity production from biogas started developing from the early 1990s with an annual output of 900 GWh (European Union, 2018) and has grown to 65,179 GWh in 2017 (EBA, 2018). The growth rate in 2017 was 4% (+2,336 GWh) after 3% and 6% in the previous years, resulting in an aggregate output surge of 7,588 GWh (EBA, 2018).

While the general trend of the main producer countries is one of slowdown (the UK, Poland, Italy), and even lower output (Germany, Austria), biogas is still enjoying double-digit growth in four countries – Denmark (34.0%, at 389 ktoe), France (14.0%, at 899.5 ktoe) Finland (11.1%, at 124.5 ktoe) and Estonia (20.5%, at 12.9 ktoe). France increased its output more than any other country in 2017 (by 110.7 ktoe). It had introduced a more lucrative remuneration system which is starting to pay off (feed-in tariff for biogas injection, higher feed-in tariff for small plants of <500 kW, tenders for >500 kW plants and tax advantages for all plants), yet still limits the food crop input allowed (Observ’ER (FR), 2018).

Power production by country was highest in Germany covering 6.63% of the final electricity consumption followed by Latvia (5.94%), Luxembourg (5.24%), Czech Republic (4.55%), Denmark (4.46%), Italy (3.28%), Slovakia (2.55%), UK (2.50%), The Netherlands (1.88%), Belgium (1.27%) and Slovenia (1.08%). In other countries, biogas to power contribution to final electricity consumption is still below 1% (EBA, 2018).

Figure 3.3 below shows the development of power conversion by biogas plants from 2011 and the shares of different feedstock types. The relevant share of unknown feedstock is due to lack of reliable data at national level (EBA, 2018).

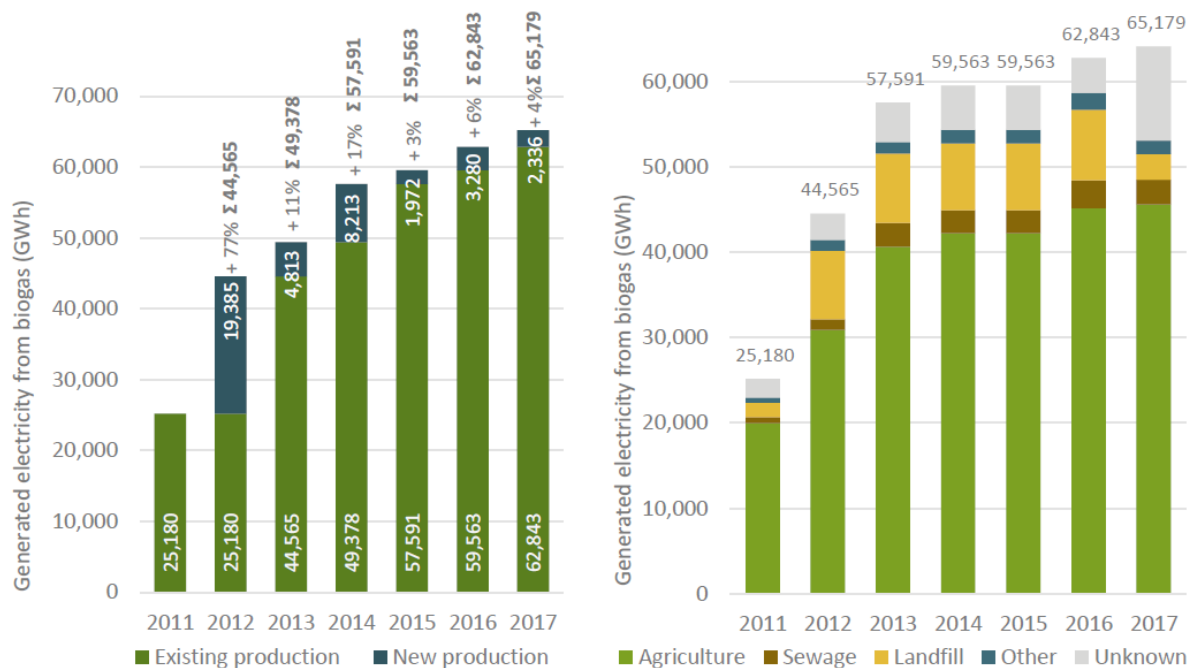

Figure 3.3 Development of total electricity production from biogas with growth rates in Europe (left), and break-down of yearly electricity production by feedstock type (right) (EBA, 2018)

### 3.2.2 Biogas to biomethane

The methane content of biogas is about 50-60% (for this study, usually 55% are calculated) depending on feedstock and digestion process. After separation of CO<sub>2</sub> and minor impurities by mature purification processes, pipeline grade biomethane is supplied that can fully replace natural gas. Consequently, biomethane is a renewable energy carrier that can be stored, transported and processed using the existing infrastructure. In addition, biomethane can be compressed or liquified and used as transport fuel – most truck manufacturers offer gas engines with equal performance to diesel engines in terms of fuel consumption and autonomy (up to 1600 km) which makes these trucks a readily available, low emission choice for long-haul, heavy duty transport. (EBA, 2018)

Since 2011 the number of biomethane plants in Europe grew from 187 facilities to 540 in 2017. They are located in Austria, Denmark, Germany, Finland, France, Hungary, Island, Italy, Luxembourg, the Netherlands, Norway, Spain, Sweden, Switzerland and the UK. In three countries, the first biomethane plants have been commissioned in 2018: Belgium, Estonia and Ireland. Total output in GWh and billion cubic meters (bm<sup>3</sup>) are shown in figure 3.4. Biomethane is calculated with a lower heating value (LHV) of 9.97 kWh/m<sup>3</sup>.

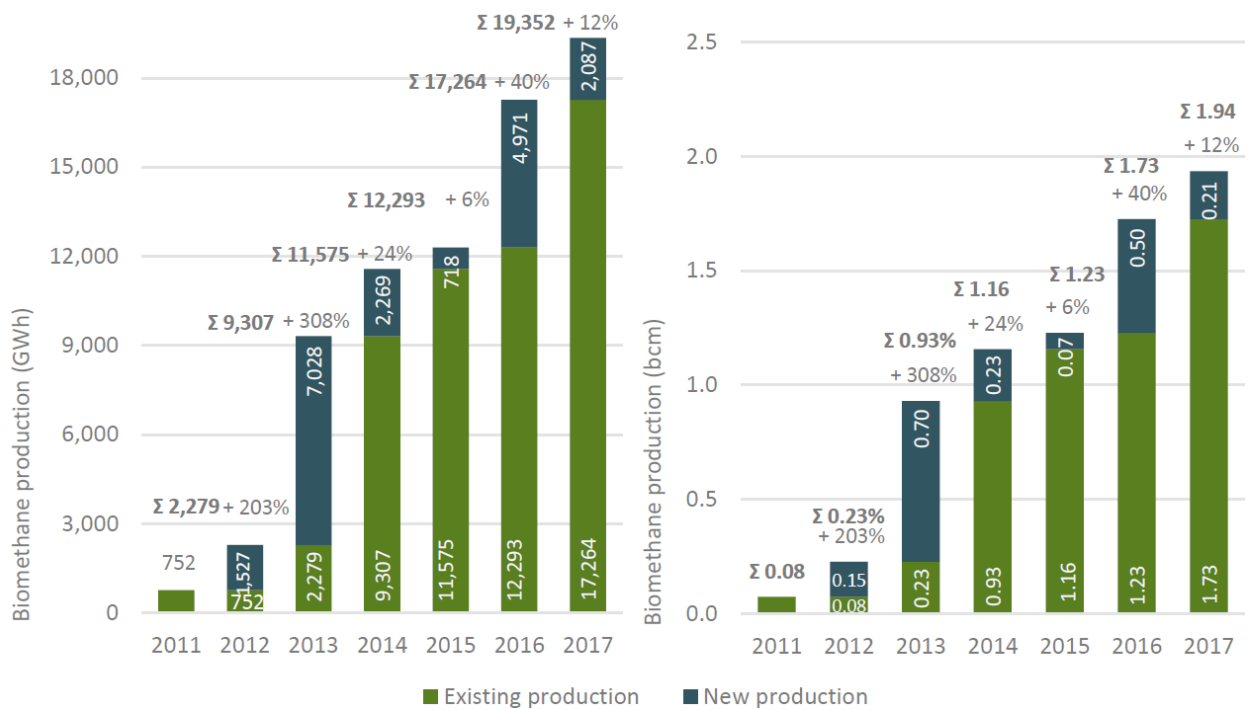

Figure 3.4 Development of European biomethane production in GWh with growth rates (left) and  $\text{bcm}^3$  (right) (EBA, 2018)

#### Advantages of biomethane over natural gas and conversion of biogas to power:

- Avoidance and mitigation of GHG emissions;
- Use of existing infrastructure, with no significant changes necessary – pipelines, network, facilities, storage in caverns/aquifers, gas turbines, appliances compatibility, etc.
- Flexibility: depending on the market situation and the infrastructure, energy can be transferred between different energy carriers;
- Non-variable: no periodic or seasonal on and off cycles;
- Dispatchable: for on-demand use, according to market needs;
- Existing and affordable consumer applications: as vehicle fuel in the form of biological compressed natural or liquid gas (bio-CNG and bio-LNG);
- Raw material: methane is a sought-after raw material in the chemical industry;
- Power-to-Methane technology and biomethane production are synergetic, can be easily integrated and have a high potential for negative emission by utilising  $\text{CO}_2$  streams from biogas upgrading.

In terms of biomethane output per capita, Denmark is in the lead with 160 kWh/person, followed by Sweden with 133 kWh/person and Germany with 121 kWh/person. Several other European countries follow suit with current outputs in the range of 40-80 kWh/person in Norway, the Netherlands, UK and Luxembourg. Details are shown in Figure 3.5 below.

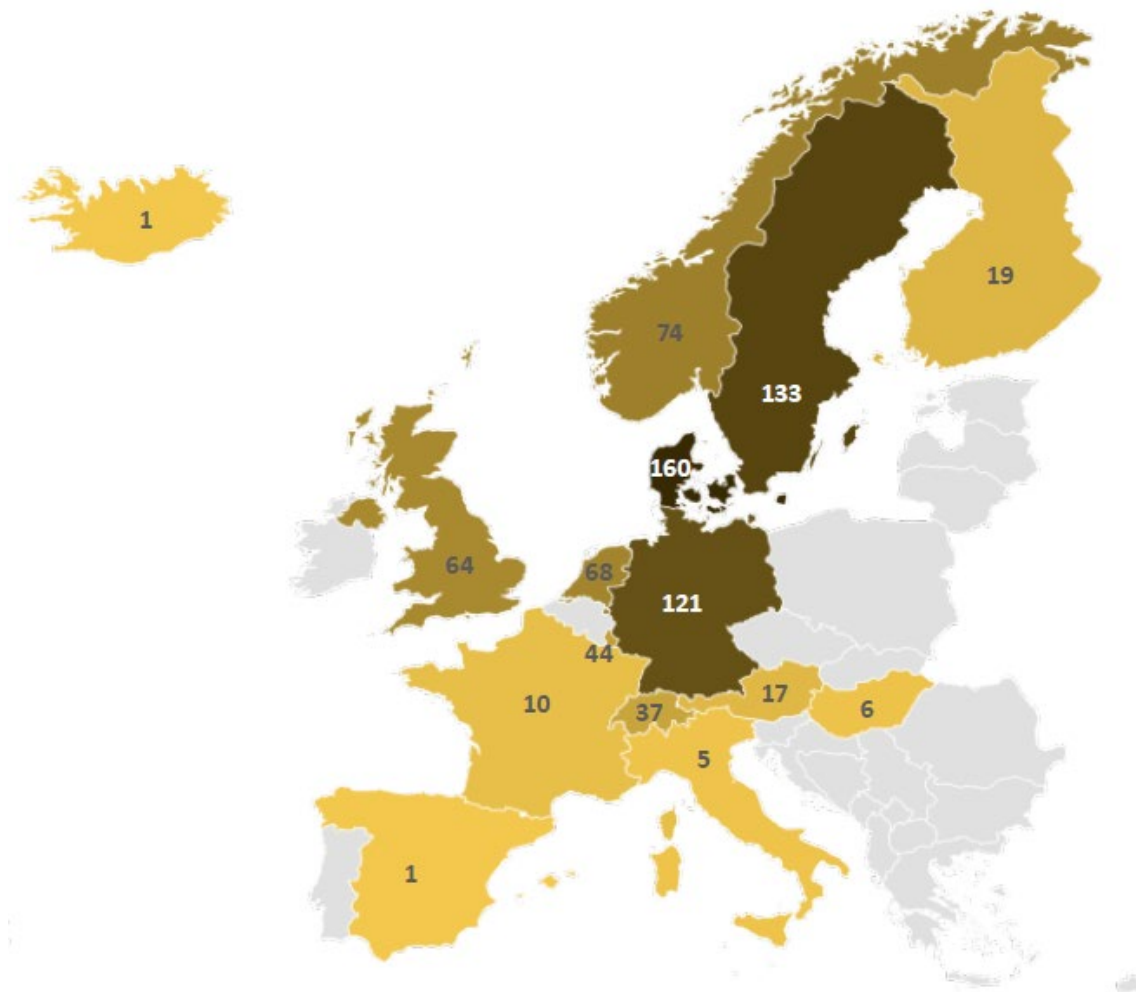

Figure 3.5 Biomethane production per capita in European countries (EBA, 2018)

### 3.2.3 Feedstock to biogas

In most countries one dominant feedstock type is used for conversion to biogas, but the feedstock may be different from country to country. In Austria, Germany, Hungary, Italy and Latvia, energy crops and agricultural residues make up more than 70% of the feedstock used. In Italy however, energy crops include a significant share of catch and cover crops. Under the slogan "BiogasDoneRight", the biogas market in Italy is being redefined, with the aim of making better use of farmland by double or multiple cropping and using the additional biomass for biomethane production, a strategy with significant benefits in terms of sustainability and greenhouse gas abatement. In Denmark, Switzerland and Poland, a large share of industrial organic wastes from the food and beverage industry is used for conversion to biogas and electricity from biogas. Sewage sludge from wastewater treatment plants is the predominant input to biogas facilities in Sweden and the UK. Figure 3.6 displays the different feedstock profiles of European countries (EBA, 2018).

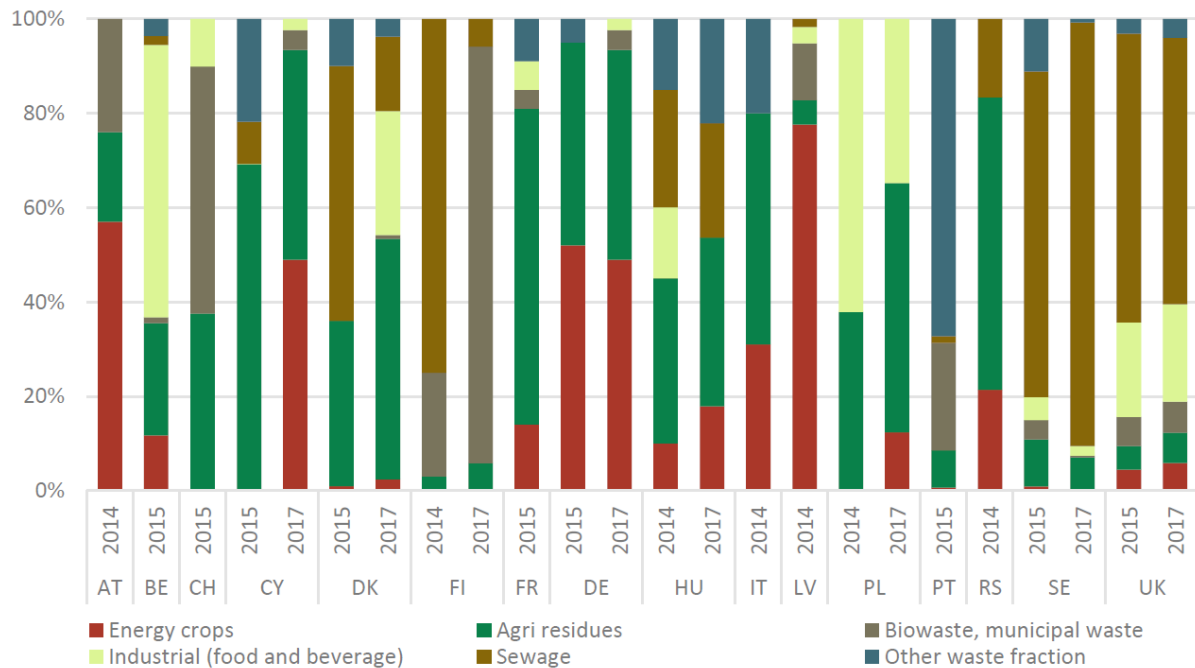

Figure 3.6 Feedstock use for conversion to biogas in European countries (excluding landfill), expressed as a mass percentage (EBA, 2018)

According to EBA (EBA, 2018), the preeminent feedstock for biogas plants are agricultural substrates comprising livestock manure, farm residues, plant residues and energy crops with a market share of 60-70%. Non-agricultural feedstock, including organic, municipal waste and organic, industrial waste from the food and beverage industry is still underrepresented (see Figure 3.6). Eurostat has slightly different figures reporting, non-hazardous waste and raw plant matter accounting for three-quarters of feedstock for biogas (74.9% in 2016) (Observ'ER (FR), 2018). Sustainable, organic residue- and waste-based as well as cover crop-based feedstocks make sure that biogas plants fully integrate into a bio-based, circular economy and do not raise land-use-change debates.

The RED II Directive, coming into force in 2021, will further boost the use of organic residues due to extending sustainability criteria from the transport sector to all energy sectors, also addressing biogas and biomethane used in the heat and power sectors. It caps the use of food and feed crops for biofuels and biogas. Producers must quantify value chain related greenhouse gas emissions and achieve at least 65% - 80% savings relative to the Fossil Fuel Comparator (FFC). For compliance, producers must focus on sustainable feedstock types as outlined in the RED II Annexes. Annex IX lists the feedstocks for advanced biofuels and biogas and Annex VI determines the default greenhouse gas emission values. Annexes are continuously reviewed (EBA, 2018).

### 3.3 Supporting schemes and targets in Member States

#### 3.3.1 Supporting schemes

A report published in August 2018 by EBA within the BiogasAction Project (<http://biogasaction.eu/>), suggests that 70.0% of biogas production in 2016 was developed thanks to the main support scheme in the relevant country. On average, a lag phase of around three years can be identified between the start of the main support scheme and a significant rise in biogas production. Adequate support schemes are crucial for the development of renewable energy (EBA, 2018). 17 Mtoe biogas output would not have been achieved without the various national schemes in place in the different EU countries. In turn, the current austerity policies having led to significant cuts to the support schemes in several countries like, for instance, Germany are reflected by a visible slowdown and a sharp decline in new projects. Since support for biogas, electricity from biogas and biomethane production remains to be decided at Member State level in the EU, the effect of the RED II Directive and the subsequent National Renewable Energy

Action Plans (NREAP) should initiate a new phase of tangible support policies towards renewable energy and biogas projects.

Preferred support schemes are Feed-in Tariffs (FiT), Feed-in Premiums (FiP) and Green Certificates (GC) that are typically based on national targets and frequently capped in terms of maximum available public budgets and tendered by the competent authorities to support the most competitive projects. These schemes may be flanked by carbon taxes and green energy quotas imposed on utilities or transport fuel suppliers similar to the established practice requiring the admixture of a certain percentage of biodiesel and bioethanol to fossil fuels.

### **Feed-in Tariff (FiT)**

A feed-in tariff is a support scheme granting a technology-specific price per unit of renewable energy. Public authorities determine and guarantee the tariff for a specified time period. The ultimate goal of a FiT is to offer cost-based compensation to renewable energy suppliers, providing fixed revenues per energy unit which are essential to finance renewable energy investments.

Feed-in tariffs are typically adjusted to the installed energy capacity (smaller plants get higher tariffs) and are guaranteed only for a determined time period. They may exclude certain feedstock types (e.g. sewage sludge) and be flanked by certain bonuses like a combined heat and power (CHP) bonus for plants that make use of the by-product heat and/or other, frequently feedstock-based bonuses. More recently, flexibility bonuses are granted for plants that provide higher storage capacities and higher installed power capacities to allow the utility to adjust power supplies to the fluctuating grid capacity due to intermittent, not demand driven power supplies from wind and solar power suppliers. FiT contracts may include degressive tariffs to encourage technological cost reductions.

### **Feed-in premium (FiP)**

A feed-in premium (FiP) aims at compensating the difference between the spot market price per unit of energy and the cost of its supply. Suppliers receive a premium on top of the market price of their electricity or biomethane output. A FiP can either be fixed at a constant level independent of market prices or sliding (floating), i.e. (periodically) adjusted according to the spot market price at which energy is supplied. Fixed FiPs are usually combined with predetermined minimum (floor) and maximum (cap) levels, either for the FiP or for the total remuneration (FiP + market price).

FiPs are typically differentiated according to conversion technologies and installed capacities in a similar way as FiTs. The same holds true for underpinning measures mentioned above like bonuses for heat use, feedstock selection, storage capacities, etc. and a degressive design of the FiP support scheme.

FiPs are more flexible than FiTs encouraging the supplier to consider ups and downs in the spot market and adapt his supplies accordingly.

### **Renewable Energy Certificates (RECs) or Green Certificates**

RECs are tradeable assets which renewable energy suppliers can sell per unit of energy supplied (e.g. to the grid) and which companies buy to offset their non-renewable energy consumption. RECs are frequently linked to quota systems whereby an industry/utility must include a determined share of renewable energy in its energy mix.

Typically, a company signs a contract to buy certificates from renewable energy supplier and it buys electricity from the market. Meanwhile, the renewable power supplier sells the electricity directly to the wholesale market. The price of RECs may depend on the type of energy, conversion technology, quotas imposed vs. renewable energy supply, etc. and is another instrument to compensate for the elevated cost of renewable energies, generally perceived as closer to a market economy.

RECs may be considered the opposite of an emission certificate. Whereas European Emission Certificates (EUAs), impose a cost on non-renewable energy use and set a maximum to total emissions, green certificates create an extra revenue for conversion of renewable feedstock and may guarantee a minimum quota of renewables in supply. Green certificate policies are in place in Poland, Belgium, Sweden and the UK.



### **Fiscal or other monetary incentives**

Tax exemptions or reductions are usually additional support systems, frequently provided for end-users e.g. tax incentives for buying a low emission car or bio-LNG/CNG exempt from fuel/road taxes. Some Member States (e.g. France) exempt renewable energy suppliers from selected taxes including CO<sub>2</sub> taxes where applicable (e.g. Finland, Sweden). Apart from periodic or permanent tax incentives, grants facilitating investments into renewable energy facilities may be offered (e.g. Norway).

### **More and frequently updated information**

Project developers and investors can find more and updated information about biogas related projects, developments and support programs in EU Member States in the BiogasAction toolbox (EBA, 2018)

- <http://tools.biogasaction.eu>

Targeted information on legislation and support schemes in EU Member States can be found under

- <http://www.res-legal.eu/home/>

Both websites are frequently updated and contain valuable information.

## **3.3.2 Biogas and biomethane policy objectives in EU Member States (EBA, 2018)**

### **Denmark**

- Cover 10% of gas consumption by 2019 by biomethane
- Ambition to become the first country to reach 100% renewable gas in the grid by 2035

### **Ireland**

- 4 TWh (0.34 Mtoe) of renewable gas injected into the gas grid by 2025
- 8 TWh (0.69 Mtoe) of renewable gas injected into the gas grid by 2028
- 12 TWh (1.04 Mtoe) of renewable gas injected into the gas grid by 2030
- 20% renewable gas consumption by 2030

### **France**

- 90 TWh (7.7 Mtoe) biogas by 2030 of which
- 1.7 TWh (0.15 Mtoe) biomethane by 2018
- 8 TWh (0.69 Mtoe) biomethane by 2023
- 60 TWh (5.16 Mtoe) biomethane by 2028
- Vision to achieve 100% renewable gas by 2050

### **Italy**

- 80 TWh (5.88 Mtoe) biogas by 2030

### **Finland**

- 15 TWh (1.29 Mtoe) biogas by 2045

### **Sweden**

- 15 TWh (1.29 Mtoe) biogas by 2030
- Vision of a fossil-free transport sector by 2050

## **3.3.3 Transport fuel related objectives in EU Member States**

Currently, the transport sector in the EU consumes 33% of the final energy, has the highest NO<sub>x</sub> and high particulate matter emissions and the lowest use of renewables among all sectors. If manure and agricultural residues are used for conversion, greenhouse gas emission savings in the order of 200% are



achievable – with current infrastructure, readily available technologies and consequently, moderate investments. Locally produced biomethane from organic municipal and industrial wastes can offer a solution which provides environmentally friendly, low greenhouse gas-emission transport fuels for public transport in urban areas, in an integrated circular economy concept (European Commission, 2018). This is one of the lowest hanging fruits in the transition to a zero-carbon economy.

To push forward the deployment of environmentally friendly transport fuels and the mitigation of emissions in the transport sector, RED II imposes an obligation for fuel suppliers to achieve at least 14% renewables in the transport sector by 2030 (EBA, 2018).

Several countries have taken targeted measures to promote the use of liquid or compressed biomethane for transport. In Nordic countries the emphasis is on heavy-good vehicles (e.g. gas driven city buses) and long-haul transport. The truck industry provides a range of modified heavy-good trucks with gas engines that offer advantages in terms of operating costs (€/km) and provide autonomies of up to 1600 km, comparable to the diesel trucks.

### **Some examples for measures related to infrastructure and promotion of bio-CNG/LNG (EBA, 2018):**

#### Germany

- 120 bio-CNG gas filling stations (100% biomethane)
- 170 gas filling stations (biomethane blend)

#### Estonia

- The new decree for the 'Implementation of measures to increase the use of vehicles that use alternative fuels (including biogas)' was enforced and has resulted in the first biomethane plant (commissioned in 2018).

#### Finland

- Roughly one quarter of biomethane production was used as vehicle fuel in 2016.

#### Ireland

- The Green Gas Certification Scheme design has been completed in 2018 and implementation starts in 2019
- The Causeway Project is rolling out 14 compressed natural gas (CNG) fuelling stations, the first fast filling station in Dublin and 3 private filling stations across Ireland.

#### Italy

- The 2017 Biomethane Decree update promotes and subsidizes biomethane use as a transport fuel up to a maximum annual production of 1.1  $\text{bm}^3$  (11 TWh or 0.94 Mtoe)

#### Norway

- In 2009, Norway, having reached its National Renewable Energy Action Plan (NREAP) 2020 target for biogas-to-power has now set a facultative goal of converting 1 TWh (0.09 Mtoe) of biogas to biomethane by 2020. A large part of it which will be used as vehicle fuel (bio-CNG or -LNG).

#### Sweden

- 175 gas fuelling stations (biomethane/bio-CNG and natural gas blend);
- 6 gas fuelling stations (biomethane/bio-LNG and LNG blend);
- 88% of biomethane production was used as transport fuel in 2017;
- Use of biomethane in transport is subsidised by tax advantages, bonuses like free parking and other benefits for low or no emission vehicles.

EBA, together with the Natural Gas Vehicle Association, estimates the potential development of gas-driven buses, trucks and light duty vehicles along such lines that, even in the most cautious of forecasts, biomethane could easily make up as much as 30% of gaseous fuels by 2030 (EBA, 2018).

### 3.4 Barriers to biogas in EU Member States

In the SYSTEMIC “Report on regulations governing AD and NRR in EU Member States” authors formulated six recommendations for a more favourable economic framework for biogas and nutrient recycling: further regulatory harmonisation in Europe, continued support for biogas and a long-term, reliable and consistent regulatory framework were considered highly relevant. RED II seems having considered these recommendations albeit, harmonisation will still be limited as Member States can choose their own pathways towards a net-zero greenhouse gas emission European Union.

Kampman et al. investigated in their EU-funded study “Optimal use of biogas from waste streams” the key barriers to biogas growth, identifying the five main barriers per sector (electricity, heating and transport) and distinguishing between the three different types of market (i.e. mature, moderate and immature market). The identification of the main five barriers was based on the selection of the main three barriers in each of the sectors per Member State. In a second step the barriers were grouped according to the predefined categories and subcategories in order to identify the top five barriers per sector per market. The data collection was to certain extent challenging since in some Member States, especially those with immature markets, there is still a lack of business cases (Kampman, et al., 2016).

The conclusion is quite similar to the one in the SYSTEMIC report: **the key barriers are existence, stability and reliability of the framework and support scheme(s)** as figures 3.7 and 3.8 clearly demonstrate (Kampman, et al., 2016)

The key barriers in all three sectors (only two graphs shown) and in all three markets relate to the existence, stability and reliability of the framework and effective support scheme(s) – clearly the key issue that determines biogas growth. Since installation of biogas plants is linked to relatively high investment cost, financial incentives and a policy framework in place that ensure profitable operation at least for the years until the investment is paid back. A well established and stable legal and political framework along with stable income from biogas production and possibly support for the investment cost reduces the payback time of the project and makes the project attractive to project developers and investors (Kampman, et al., 2016)

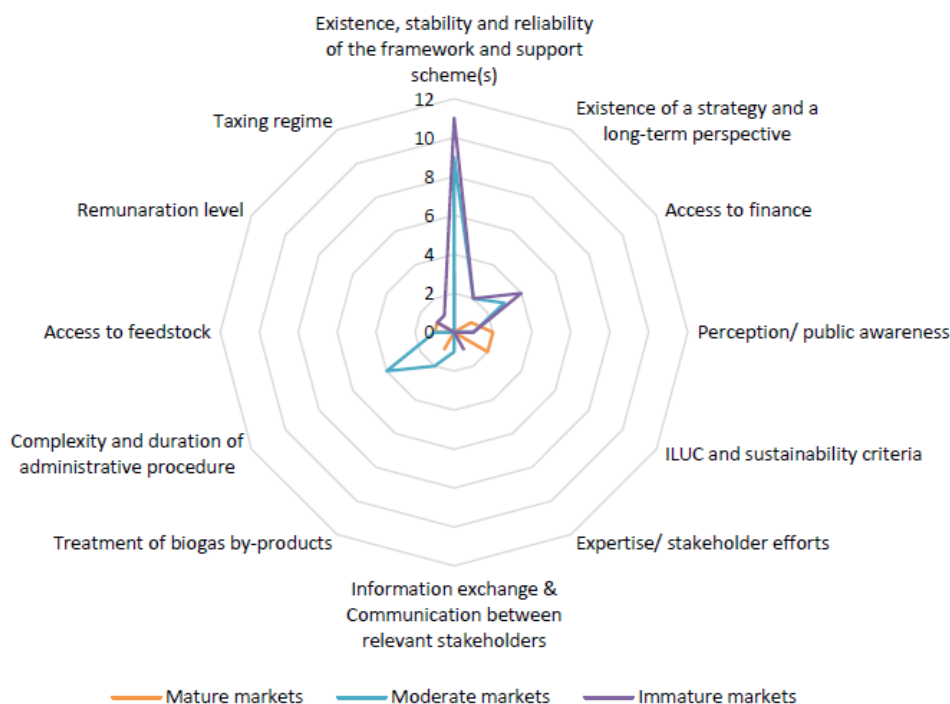

Figure 3.7 Barriers for electricity generation from biogas/biomethane (Kampman, et al., 2016)

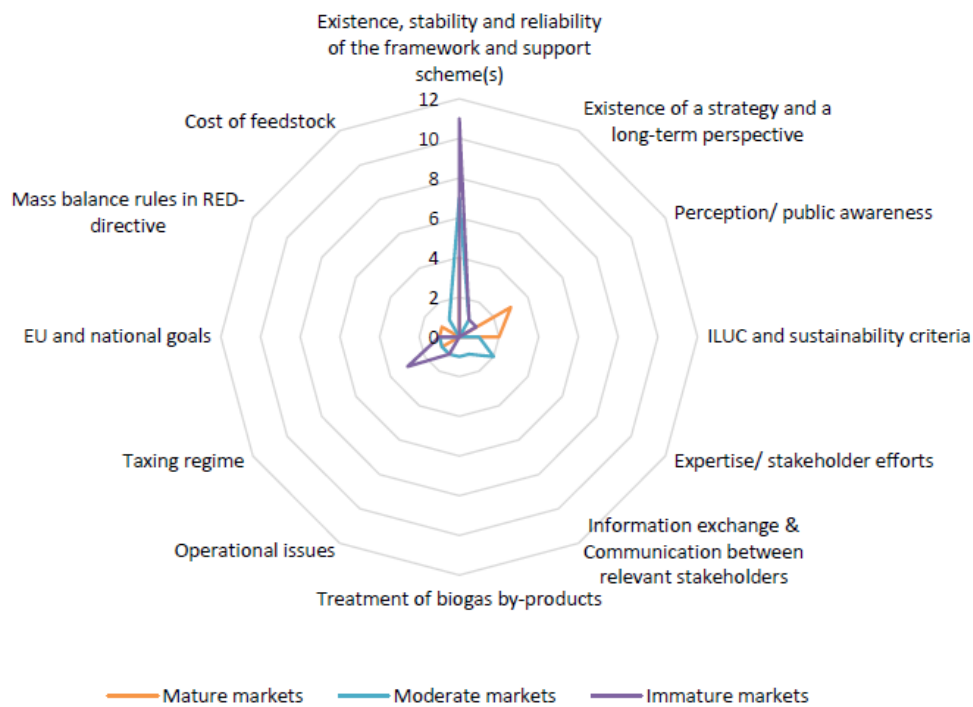

Figure 3.8 Barriers for biogas/biomethane in the transport sector (Kampman, et al., 2016)

Barriers related to the policy framework and support have been detected in 22 Member States in the electricity sector, 20 Member States in the heating sector and 16 Member States in the transport sector (Kampman, et al., 2016).

With regards to electricity sector in mature markets, this barrier has (had) been identified in Germany, France, and the United Kingdom. In Germany, lack of support schemes sufficiently promoting the extended usage of biogas is the main barrier for further development of biogas in all three sectors. In the United Kingdom, the main barrier hindering biogas projects in all three sectors is the permanent revision of support schemes. In France, biogas projects have suffered from different interpretation of regulatory requirements for emission thresholds in the regions (this barrier should have been removed by new regulation recently). In moderate markets, framework and support schemes related issues have been communicated as a barrier in several Member States including Denmark, Finland, Hungary, the Netherlands, Portugal and Poland. The issues vary from country to country – from reliability problems and permanent revision of schemes in the Netherlands to a lack of visibility of supporting schemes beyond 2020 in Denmark, or lack of support schemes for new plants in Italy (Kampman, et al., 2016).

In immature markets, projects in several Member States are (or were) suffering from lack of incentives for biogas (Bulgaria, Spain, Ireland, Cyprus, Luxembourg), which hampers the access to financing for biogas projects.

Framework and support schemes related issues in the heat sector have been communicated by less Member States, however the problem in this sector can be expected to be more severe, since the number of Member States having no support for heat generation from biogas/biomethane exceeds the number in the electricity sector (Kampman, et al., 2016).

In contrast to the other two sectors, missing incentives in the transport sector have been a barrier also in mature markets like Austria, France and Germany (Kampman, et al., 2016).

# 4 Biogas Potential and Trends in Europe

## 4.1 EU 2050 low or net-zero carbon energy forecast scenarios (European Commission, 2018)

The Commission has developed and studied eight different pathways (hereafter also called scenarios or long term strategy options). All include a wide range of technological and organisational options to reduce emissions. Some pathways focus on specific technologies or options, others focus more on demand-side measures, such as promoting energy efficiency or a circular economy.

Scenarios 1 and 2 illustrate possible GHG emission pathways and mitigation potentials only based on technologies that are available today. Both scenarios count on greenhouse gas reductions that are either a linear extrapolation of past trends ("business as usual" scenario 1) or due to the use of best available technique (BAT) potentials (scenario 2). Scenario 1 can be interpreted as a baseline scenario to which the results of other scenarios can be compared. In terms of diffusion of today's BAT, scenario 2 is more ambitious but still does not consider new disruptive technologies to enter the market.

The long term strategy options (forecast scenarios) frequently referred to in this chapter are briefly explained in Figure 4.1.

Long Term Strategy Options								
	Electrification (ELEC)	Hydrogen (H2)	Power-to-X (P2X)	Energy Efficiency (EE)	Circular Economy (CIRC)	Combination (COMBO)	1.5°C Technical (1.5TECH)	1.5°C Sustainable Lifestyles (1.5LIFE)
<b>Main Drivers</b>	Electrification in all sectors	Hydrogen in industry, transport and buildings	E-fuels in industry, transport and buildings	Pursuing deep energy efficiency in all sectors	Increased resource and material efficiency	Cost-efficient combination of options from 2°C scenarios	Based on COMBO with more BECCS, CCS	Based on COMBO and CIRC with lifestyle changes
<b>GHG target in 2050</b>	-80% GHG (excluding sinks) ["well below 2°C" ambition]					-90% GHG (incl. sinks)	-100% GHG (incl. sinks) ["1.5°C" ambition]	
<b>Major Common Assumptions</b>	<ul style="list-style-type: none"> <li>Higher energy efficiency post 2030</li> <li>Deployment of sustainable, advanced biofuels</li> <li>Moderate circular economy measures</li> <li>Digitilisation</li> </ul>				<ul style="list-style-type: none"> <li>Market coordination for infrastructure deployment</li> <li>BECCS present only post-2050 in 2°C scenarios</li> <li>Significant learning by doing for low carbon technologies</li> <li>Significant improvements in the efficiency of the transport system.</li> </ul>			
<b>Power sector</b>	Power is nearly decarbonised by 2050. Strong penetration of RES facilitated by system optimization (demand-side response, storage, interconnections, role of prosumers). Nuclear still plays a role in the power sector and CCS deployment faces limitations.							
<b>Industry</b>	Electrification of processes	Use of H2 in targeted applications	Use of e-gas in targeted applications	Reducing energy demand via Energy Efficiency	Higher recycling rates, material substitution, circular measures	Combination of most Cost-efficient options from "well below 2°C" scenarios with targeted application (excluding CIRC)	COMBO but stronger	CIRC+COMBO but stronger
<b>Buildings</b>	Increased deployment of heat pumps	Deployment of H2 for heating	Deployment of e-gas for heating	Increased renovation rates and depth	Sustainable buildings			CIRC+COMBO but stronger
<b>Transport sector</b>	Faster electrification for all transport modes	H2 deployment for HDVs and some for LDVs	E-fuels deployment for all modes	Increased modal shift	Mobility as a service			<ul style="list-style-type: none"> <li>CIRC+COMBO but stronger</li> <li>Alternatives to air travel</li> </ul>
<b>Other Drivers</b>		H2 in gas distribution grid	E-gas in gas distribution grid				Limited enhancement natural sink	<ul style="list-style-type: none"> <li>Dietary changes</li> <li>Enhancement natural sink</li> </ul>

Figure 4.1 Overview of the EU FORECAST / long term strategy scenarios (WWF Briefing Paper, 2019)

## 4.2 Biogas/biomethane potential

Biomethane related technologies have seen considerable progress in terms of efficiency and maturity. A currently untapped resource is using Power-to-Methane (P2M) technology by which CO<sub>2</sub>, after separation from biogas for biomethane supply, can be reacted with renewable hydrogen produced from excess renewable electricity. Hydrogen and CO<sub>2</sub> react to renewable methane which can fully avoid greenhouse gas emissions from anaerobic digestion and virtually double the biomethane output of a traditional AD

plant. Several studies (European Commission, 2018) (Observ'ER (FR), 2018) (EBA, 2018) conclude that based on the existing biogas and biomethane output, around 13.5  $\text{bm}^3$  of  $\text{CO}_2$  could be methanised (P2M), exploiting 54  $\text{bm}^3$  of renewable hydrogen. However, to produce such an amount of renewable hydrogen, around 213 TWh (18.3 Mtoe) of excess (peak supply) renewable electricity would be necessary, corresponding to the current final electricity consumption in Spain. Using carbon dioxide waste streams will significantly increase the biomass conversion efficiency and the overall technological effectiveness of the plants, as well as increase the value of renewable electricity because of the additional storage capacity.

Depending on the sector, gaseous fuels will be necessary and natural gas can be replaced by carbon-neutral forms of gas like biomethane or e-gas (the conversion product of captured  $\text{CO}_2$  and hydrogen from excess electricity) or possibly by hydrogen, which can substitute some traditional uses of gas (e.g. in buildings heating) but which cannot be used in all industrial applications (European Commission, 2018).

As shown by the current consumption pattern shown in this report, biomethane is increasingly used in decarbonisation scenarios (Figure 4.2) as it is fully interchangeable with natural gas and its combustion is considered having low or zero greenhouse gas emissions or even having a negative emission value (e.g. if manure is used as feedstock). If RED II is systematically implemented in EU Member States, total consumption of biogas would increase from 17 Mtoe (198 TWh) in 2017 to about 30 Mtoe (349 TWh) in 2030 and then range between 45 Mtoe (523 TWh, EE scenario) and 79 Mtoe (919 TWh, P2X scenario) in 2050 – close to five times the current supply - and will be mainly used in the power and industry sectors. These projections are in line with other studies that also see a potential for a much higher contribution renewable gas in the EU energy system. For instance, the Green Gas Grids Project estimated that a supply of 48–50  $\text{bm}^3$  (about 50 Mtoe) of biogas (including raw biogas, biomethane and syngas) could be achieved by 2030, out of the technical potential of 151  $\text{bm}^3$  (about 130 Mtoe), hence almost tripling the current production level within the next decade. The Gas for Climate study expects biomethane to reach up to 92  $\text{bm}^3/\text{year}$  in 2050 (about 84 Mtoe), hence about 34% of current natural gas consumption (European Commission, 2018). Figure 4.2 shows the consumption of biomethane and waste-based gases by industry sector in the different scenarios.

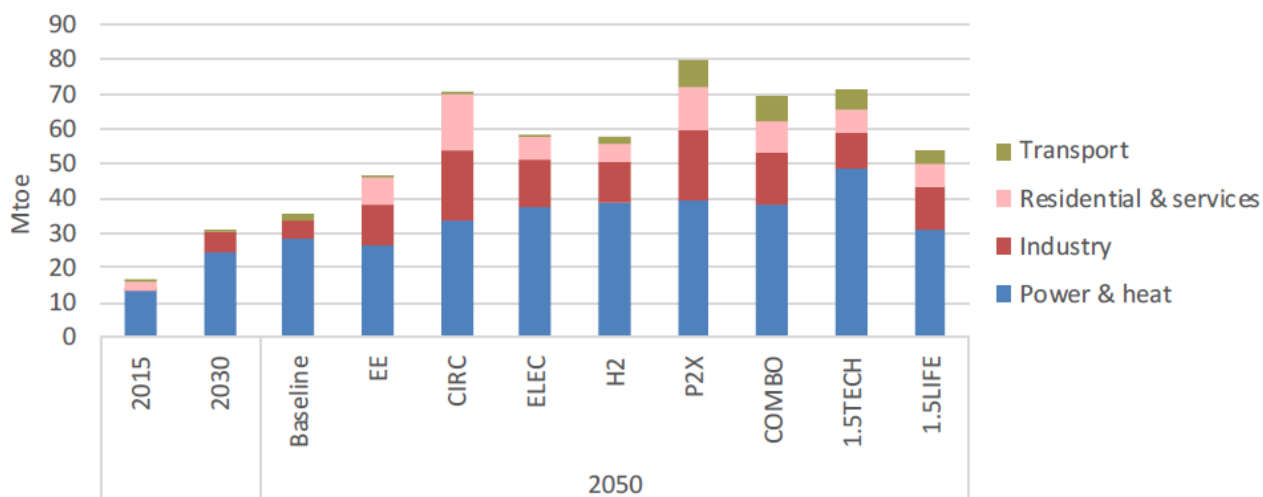

Figure 4.2 Consumption of biogas and gas from waste by sector in different EU-2050 scenarios (residential & services includes agriculture) (European Commission, 2018)

As previously discussed, all EU-2050 pathways forecast a decreasing final energy consumption in comparison to 2016. Starting from a final energy consumption in the EU of 1108 Mtoe in 2016, a final energy consumption of about 1050 Mtoe is expected for 2030 and, depending on the scenario, a final energy consumption of about 620-820 Mtoe can be expected for 2050.

Fossil fuels, which represented 43% of the electricity production in 2015, become marginal contributors the decarbonised power system. In fact, by 2050, natural gas is the only fossil fuel left in the mix, with a share (of the production) falling from 16% in 2015 to 12% in 2030 and then in 2050 to between 5%

(P2X) and 1% (EE, CIRC) and the scenarios achieving highest GHG reductions that lie within this range. It can be noted that the use of biogas in the power system develops, and, with a consumption between 22 and 45 Mtoe in 2050 in the decarbonisation scenarios, comes closely on par with natural gas in several of the decarbonisation scenarios (European Commission, 2018).

The overall fuel mix in final demand also changes significantly and the specific drivers are described for each of the sectors. Looking at overall picture the following trends can be noticed. First of all, solids, already marginal in 2030 disappear by 2050 and that already in the Baseline. Fossil liquids and natural gas remain in the system, but their quantities are substantially reduced. In these scenarios where e-fuels develop (P2X, COMBO, 1.5 TECH and 1.5 LIFE), fossil liquids and natural gas are partially replaced by e-fuels: e-liquids represent 3%-7% of the final demand in 2050 whereas e-gas represents 7%-10% of the final demand in 2050. Figure 4.3 shows the different energy carriers in supply (European Commission, 2018).

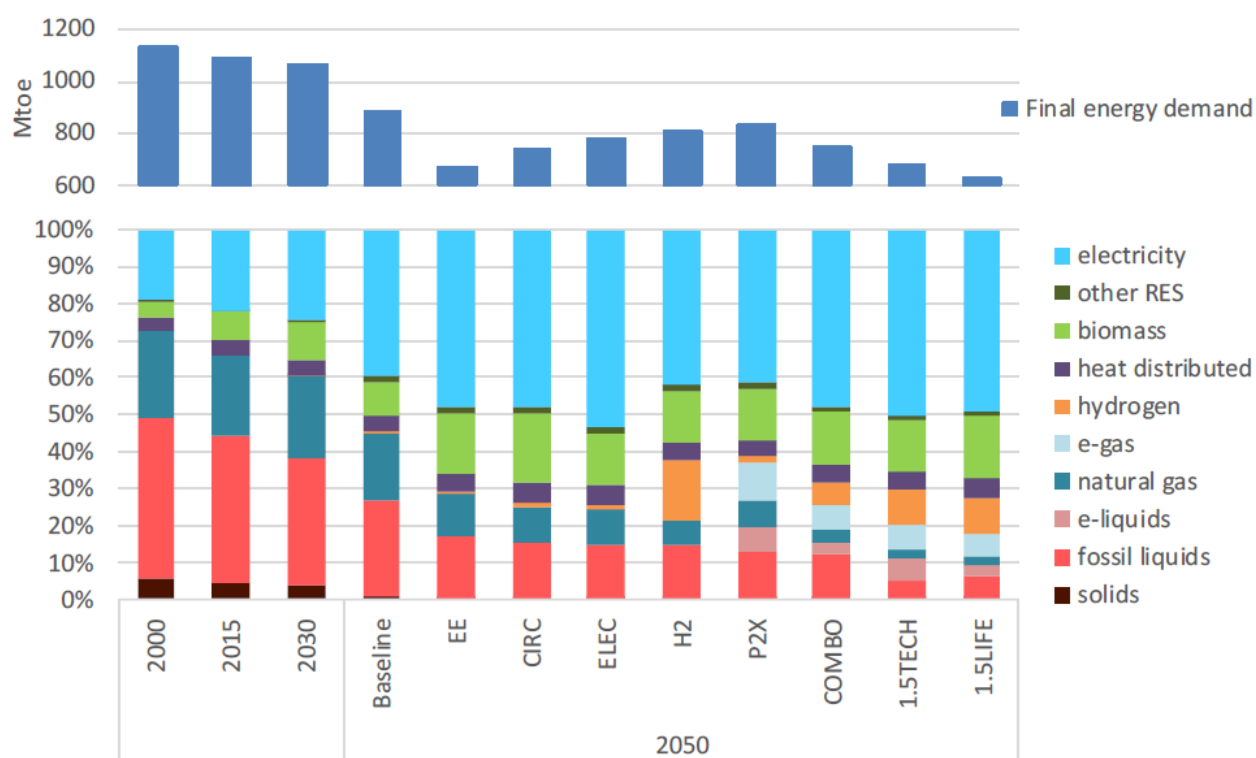

Figure 4.3 Share of energy carriers in final energy consumption in 2050 (e-gas = gas from reaction of renewable hydrogen and CO<sub>2</sub>) (European Commission, 2018)

Summing up the developments for natural gas, e-gas and biogas, in the Baseline scenario, gas gross inland consumption (covering all gas types, before conversion losses and non-energy use) stands at 320 Mtoe in 2030 and declines only slightly thereafter (compared to 370 Mtoe in 2015 vs. 245 Mtoe final energy consumption). In the decarbonisation cases, the total consumption in 2050 (Figure 4.4) varies from some 300 Mtoe (P2X, which projects the highest quantities of e-gas) to some 150 Mtoe (EE, which reduces the overall energy demand with energy efficiency measures). Scenarios that achieve close to complete emission reduction are in this range, as they forecast a rather moderate substitution of natural gas by e-gas, complemented by a substantial role of biogas but also by high levels of savings due to high energy efficiency as well as circular economy and consumer choice curbing the overall energy demand for 1.5 LIFE. The projections indicate that the development of both e-gas and biogas could play a key role in making the best use of the existing EU natural gas infrastructure in a decarbonised energy system (European Commission, 2018).



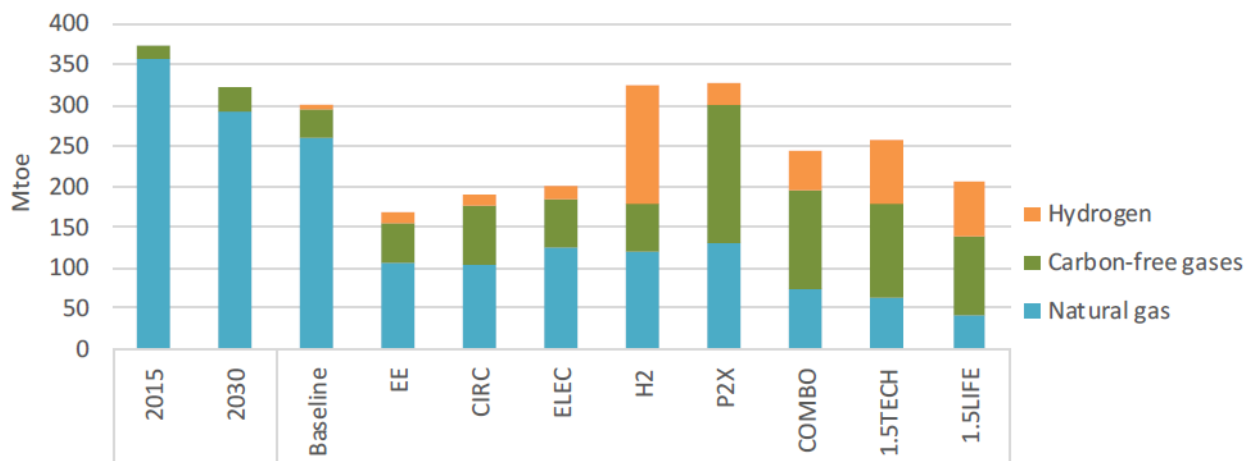

Figure 4.4 Gross inland gas consumption per gas type in 2050, "carbon-free" gases referring to e-gas, biogas and waste-gas (European Commission, 2018)

### Transport fuels (European Commission, 2018)

Regarding transport fuels for heavy goods vehicles (HGVs) the scenarios reflect the uncertain and diverse technology expectations: they show a variety of HGV technologies being used in different circumstances, depending on technology preferences, the distance travelled, the load, and the infrastructure choices that are available.

The heavy goods vehicles (HGV) stock is currently almost entirely dominated by conventional diesel powertrains. In the Baseline scenario their share is projected to decrease significantly (to around 51% by 2050, excluding hybrids), driven by the CO<sub>2</sub> standards for new heavy goods vehicles. Gas-fuelled vehicles are projected to represent around 18% of the HGV stock in 2050 and hybrids around 29%. Overall, electric and fuel cell vehicles would only provide around 2% of the stock by 2050 in the Baseline scenario. It should be noted that the Baseline scenario keeps the CO<sub>2</sub> standards for new heavy goods vehicles unchanged post-2030, consistent with the Commission's proposal for 2030. Further evolution is thus driven by the turnover of the fleet, technological progress and the assumed availability of refuelling infrastructure for LNG.

Looking at the scenarios reducing CO<sub>2</sub> emissions by 80% by 2050, hybrids would represent 22-33% of the HGV stock in 2050. Electric drivetrains (fully electric and HGVs with pantograph) would provide 17-20% of the stock in the EE and ELEC scenarios, but only 3 and 6% in the P2X and CIRC scenarios, respectively. Fuel cells are projected at 15% of the vehicle fleet by 2050 in the H<sub>2</sub> scenario, driven by the faster learning assumptions for fuel cells and the large scale availability of hydrogen refuelling stations. Gas-fuelled vehicles would represent 14% of the stock in the H<sub>2</sub> scenario and 35% in the P2X scenario by 2050. At the same time, conventional diesel drivetrains, excluding hybrids, are projected to still provide 37-58% of stock by 2050 in the scenarios reducing CO<sub>2</sub> emissions by 80% by 2050. However, the carbon intensity of fuels would be reduced due to the blending of advanced biofuels in diesel, and in addition by e-liquids in the P2X scenario. Similarly, the blending of biomethane and e-gas reduces the carbon emissions of gas-fuelled heavy goods vehicles. Thus, low carbon fuels reduce the greenhouse gas emissions of trucks, even when used in conventional drivetrains. As an example, the use of liquid biofuels in trucks by 2050 ranges from 21% in the H<sub>2</sub> scenario to 26-27% in ELEC and EE scenarios, and up to 34% in the CIRC scenario. In P2X, liquid biofuels only make up 8% of the energy demand, as e-liquids provide around 21% of the fuel mix and gaseous fuels another 44% (of which 21% is e-gas, 9% biomethane and 14% natural gas). E-liquids and e-gas are nearly absent in the other scenarios reducing CO<sub>2</sub> emissions by 80% by 2050 while gaseous fuels, including biomethane, would provide around 7% of the fuel mix in the H<sub>2</sub> scenario.

The COMBO scenario shows moderate uptake of electric drivetrains and fuel cells (around 10% of the stock) by 2050, while hybrids would represent around 19% and gas-fuelled vehicles 32% of the stock. As in the scenarios reducing CO<sub>2</sub> emissions by 80% by 2050, the fuel mix plays an important role in

driving the greenhouse gas emissions reduction. For example, e-liquids are projected at around 11% of the energy demand of trucks, hydrogen at 14%, liquid biofuels at 16% and gaseous fuels at around 33% of the fuel mix (of which more than 15% is e-gas, 8% biomethane and 9% natural gas). In the 1.5 TECH and 1.5 LIFE scenarios, as illustrated in Figure 4.5, the uptake of powertrains by 2050 is broadly similar to the COMBO scenario. However, the uptake of low carbon fuels in the mix, in particular of e-fuels and biofuels, is higher. Both COMBO and the scenarios reaching net zero by 2050 would require significant deployment of refuelling infrastructure for hydrogen and gaseous fuels.

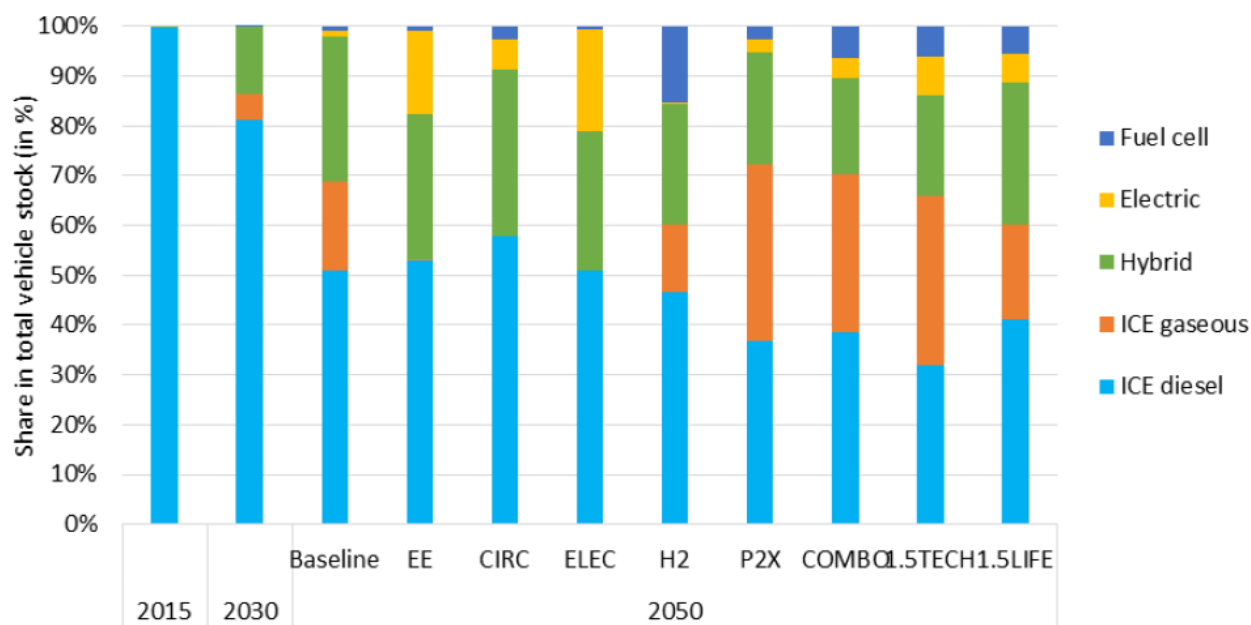

Figure 4.5 Shares in total heavy goods vehicles (HGV) stock by drivetrain technology in the Baseline and scenarios reaching -80% to net zero emissions by 2050. ICE = internal combustion engine (European Commission, 2018)

Generally, for HGVs, the PRIMES model suit scenarios show that ICE and hybrid powertrains using fuel blends with very low carbon intensity, either liquid or gaseous, would represent the dominant technology. However, hydrogen would also play a significant role for long distance road haul and electricity in particular for urban deliveries. Given the high uncertainties, care should be taken when interpreting these results.

The IEA has analysed Scenarios for the Future of Trucks. In the Reference Case, penetration of alternative drivetrains remains limited. The Modern Truck Scenario implements a large number of systemic efficiency improvements, as well as vehicle technology improvements. By 2050, drivetrains remain varied, with electrification becoming important for light trucks, especially for urban delivery, and a variety of technologies, from conventional diesel, hybrids, LPG/CNG and some electrification being used for medium and long-haul heavy good trucks. While the report states that the price of fuel cells can be brought down to become competitive, the uncertainty is still large. As in the PRIMES scenarios underpinning this strategy, no obvious technology winner appears for trucks (International Energy Agency (IEA), 2019). However, a recent report by Scania shows battery electrification as the most cost-effective option, providing an alternative viewpoint (European Commission, 2018).

For buses and coaches, the Baseline scenario projects significant uptake of hybrids (36%) and gas-fuelled vehicles (21%) as a share of the stock by 2050. Electric drivetrains (battery and trolleys) would represent around 5% of the fleet in 2050. However, in the scenarios reaching minus 80% to net zero emissions by 2050, the picture is mixed due to their different uses and technologies available. While buses are mostly used in the urban environment where electrification is a viable option, coaches travel longer distances and face similar limitations to those faced by heavy goods vehicles. For buses, the EE, ELEC and CIRC scenarios show almost full electrification of the vehicle fleet by 2050. In the H<sub>2</sub> scenario fuel cells are dominant in the stock (84%) while electric vehicles (battery and trolleys) represent around 16% in 2050. However, in the P2X scenario, conventional diesel drivetrains still represent around 26% of



the stock and gas-fuelled vehicles around 24% in 2050, while electric buses reach 41% of the stock by 2050. In the P2X scenario, low carbon fuels like e-gas, e-liquids, liquid and gaseous biofuels play a significant role in the greenhouse gas emissions reduction. COMBO and the scenarios reaching net zero emissions by 2050 show shares of electric buses in the range of 79-88%, while fuel cells would represent between 3% and 14% and gas-fuelled vehicles between 6 and 8%. In addition, e-gas, e-liquids, liquid and gaseous biofuels play a significant role in reducing the carbon intensity of fuel used in ICE powertrains. For coaches, the outcome is relatively similar to that for heavy goods vehicles, although fuel cells gain significant market shares in the 1.5 TECH and 1.5 LIFE scenarios.

A driver for bio-CNG or bio-LNG use in the transport sector could be the very favourable greenhouse gas balance. The average well-to-wheel greenhouse gas emission reduction potential lies between 66% and 97% and can be negative if manure is used as feedstock for anaerobic digestion.

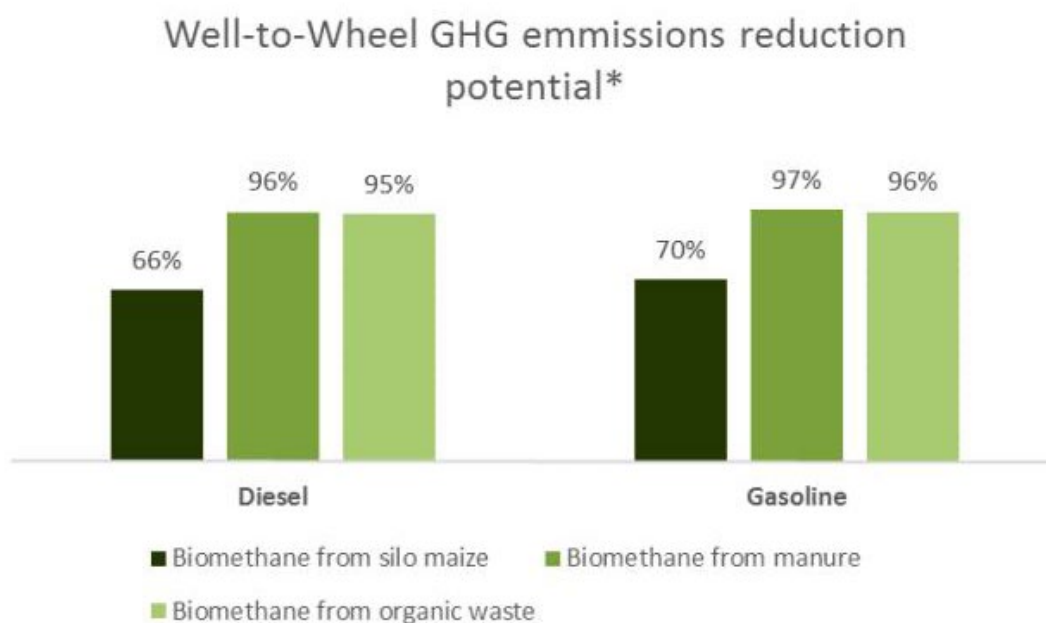

Figure 4.6 Well-to-Wheel GHG emissions reduction potential of biomethane compared to diesel/gasoline (EBA, 2016) \*The data do not include the avoided emissions of raw manure storage, landfilled organic waste and benefits of the produced digestate able to replace mineral fertilisers

#### Organic feedstock availability (European Commission, 2018)

All the scenarios analysed in the PRIMES-GAINS-GLOBIOM model suit set-up (European Commission, 2018) rely on a substantial use of biomass for energy. The 2050 gross inland consumption of biomass and waste of these scenarios is ranging from 190 Mtoe in the EE scenario to just over 250 Mtoe in 1.5 TECH scenario (in 2016 the energy sector consumed 140 Mtoe of biomass). The demand for biomass is similar for all scenarios until 2030 but diverges afterwards with more demand in the net zero GHG scenarios than in the scenarios achieving 80% GHG reduction until a peak in 2045 (dash line in Figure 4.7). Post 2045 the biomass demand is decreasing in net zero GHG scenarios, partly due to the deployment of other energy carriers (including the introduction of e-fuels). The scenarios achieving 80% GHG reduction continue to increase their biomass consumption after 2045.

In addition to the standard scenarios, a low biomass variant of the 1.5 LIFE scenario has been introduced, 1.5 LIFE-LB, to better analyse the implications of achieving net zero GHG emissions with less increases in biomass use. Most of the characteristics of the 1.5 LIFE scenario apply to this variant (circular economy, changing consumer preference and a high incentive to enhance the natural land use sink). However, compared to the standard 1.5 LIFE, the 1.5 LIFE-LB variant combines this with much more use of technology options available in 1.5 TECH scenario that require less biomass. This results in considerably less use of biomass, with particular implication on its use in industry, residential and transport sectors. The biomass use development in the different scenarios is shown in figure 4.7.

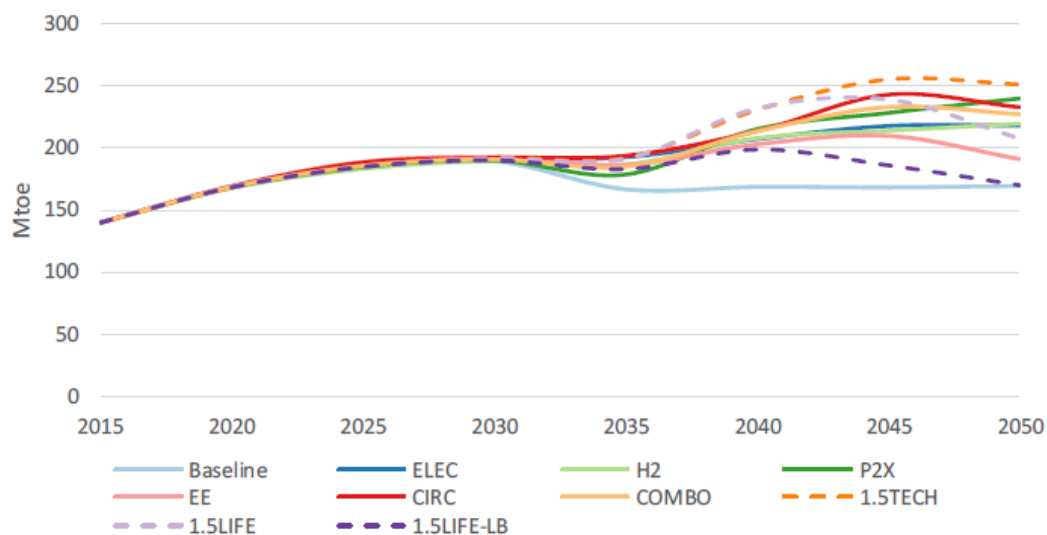

Figure 4.7 Gross inland consumption of biomass and waste (European Commission, 2018)

Power generation and residential heating are consuming today most of the biomass demand. Towards 2050 the use of biomass in the residential sector is expected to significantly decrease in all scenarios whereas the power and industrial sectors would absorb most of the additional demand in bioenergy. About 40% of the total biomass would be used to produce electricity in a demand-side scenario (EE, CIRC) and up to 75% in the 1.5 LIFE-LB. The 1.5 LIFE-LB scenario stands out by its low requirement in biomass for industry through the high penetration of hydrogen and electricity for industrial heating as well as a very strong reduction of biomass used for residential heating and less use in transport. The decarbonisation of road and air transport requires advanced biofuels that could be produced at scale after 2030, nevertheless it would not represent more than 20% of the total use of biomass in any of the scenarios – see use of biomass by sectors in figure 4.8 (European Commission, 2018).

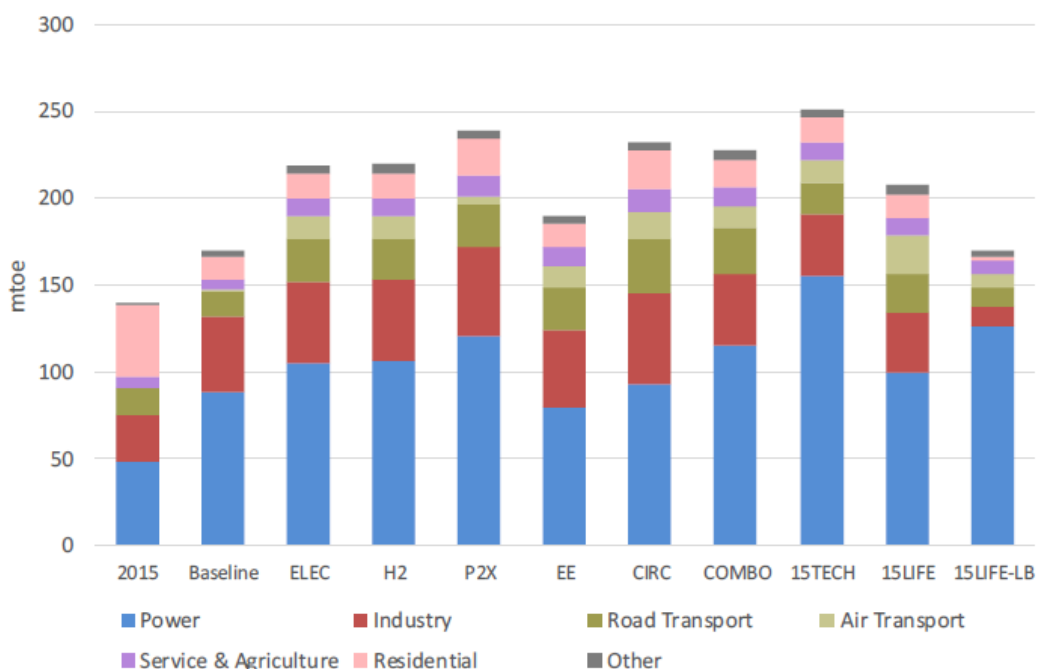

Figure 4.8 Use of bioenergy by sectors and by scenario in 2050 (European Commission, 2018)

All scenarios assume that most of the biomass used in the 2050 EU economy is produced domestically (only 4 to 6% of the solid biomass is imported by 2050, no assessment has been made on the overall climate impacts if biomass were to be imported instead). The domestic production of feedstock to fulfil

the EU demand for bioenergy is ranging from 214 Mtoe in the 1.5 LIFE-LB scenario to more than 320 Mtoe in 1.5 TECH scenarios (Figure 4.9).

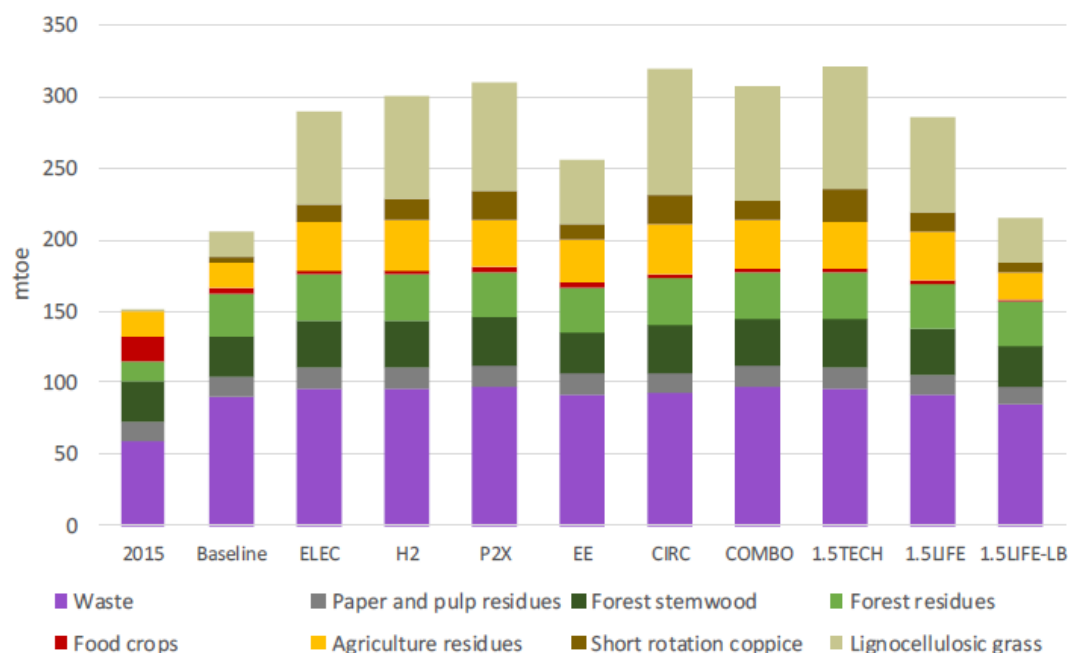

Figure 4.9 Break down of bioenergy feedstock in 2050 (European Commission, 2018)

A significant share of the feedstock used to produce this bioenergy is coming from the waste sector with an improvement in the industrial and municipal waste collection that could supply about 100 Mtoe of feedstock to the energy sector. The use of harvested stem wood stays at the 2015 level in all scenarios while the sustainable extraction of forest residues increases, in total the forest sector provides 60 to 65 Mtoe of wood for energy. Biogas or biofuels produced from food crops will be marginal in EU by 2050 but more agriculture residues are used for the production of biogas or solid biomass. The optimisation of the sustainable exploitation of all these classical sources of biomass could supply just over 200 Mtoe of feedstock for bioenergy production to the EU economy (European Commission, 2018).

Fast growing energy crops will provide for the rest of needs in biomass. Scenarios vary substantially in their demand for these new energy crops. The 1.5 LIFE-LB scenario requires 38 Mtoe of bioenergy whereas the demand in CIRC and 1.5 TECH reach 108 Mtoe. Most of the demand is supplied via lignocellulosic grass such as switchgrass and miscanthus while short rotation coppices, poplar and willow, provide only 20 to 25% of the demand in energy crops.

**Stakeholder expectations and opinions on the future of the energy system** (European Commission, 2018)

When asked to rank the importance of energy technologies in the clean energy transition, respondents indicated that renewable energy was the most preferred technology with the highest average rating of 4.37 (see the average rating, including the ranking of technologies in Figure 4.10). The least important role was envisaged for fossil fuels with carbon capture and sequestration with the lowest average rating of 2.14.

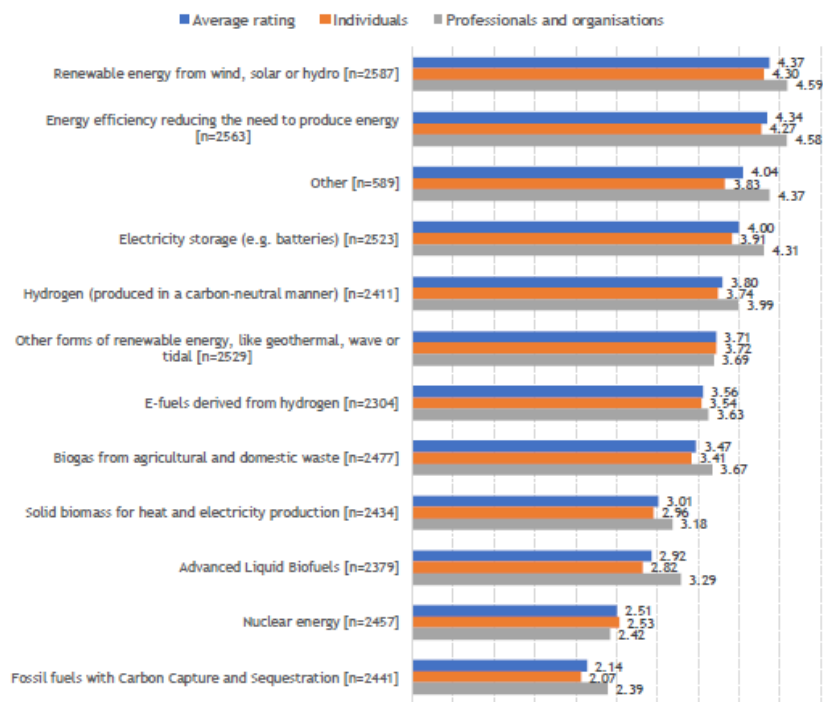

Figure 4.10 Stakeholder ranking of energy technologies (from 1 = not important to 5 = very important) (European Commission, 2018)

An even more favourable scenario with almost twice the potential estimated in the studies commissioned by the European Commission, is laid out in a Navigant study, which has been published recently. The study was initiated by a group of gas-grid utilities and shows that the grid industry is interested in the supply of biomethane.

**Navigant ([www.navigant.com](http://www.navigant.com)) Gas for Climate Forecast** (Terlouw , et al., 2019)

The "Gas for Climate: a path to 2050" initiative advocates an affordable solution in the transition towards a sustainable energy system and highlights the role of renewable gas. Gas for Climate estimates that by 2050, annual sustainable biomethane production could reach 1,072 TWh (110 Bm<sup>3</sup> / 92 Mtoe) representing roughly 22% of current natural gas consumption. Additionally, around 24 bm<sup>3</sup> of renewable hydrogen can be produced by converting low cost wind and solar electricity. Thus, a combined renewable gas potential of 122 bm<sup>3</sup> (1186 TWh / 102 Mtoe) of renewable gas per year is possible. This valuable renewable energy should be allocated over those economic sectors where highest societal cost savings are possible: heating and power generation, transport and additionally heavy industry. According to the study, taking into account the remaining 72 bm<sup>3</sup> for heating and power generation from sustainable biomethane and hydrogen will allow annual societal cost savings of 138 billion € by 2050, an equivalent of 600 € for each EU household (van Melle, et al., 2018).

As in the previous Gas for Climate study, Navigant concludes that biomethane production in the EU can be scaled up significantly. Today, biomethane production totals 2 bm<sup>3</sup>, even though biogas production has already reached a significant scale of 14 bm<sup>3</sup>. It is possible to increase biomethane production sustainably while ensuring that biomethane will be a net-zero emissions renewable gas. By 2050, a quantity of 22 bm<sup>3</sup> of biomethane could be produced based on the anaerobic digestion of agricultural wastes, food waste, and sewage sludge plus 41 bm<sup>3</sup> from the anaerobic digestion of sustainable silage cultivated as autumn, winter, and spring crop and 33 bm<sup>3</sup> from the thermal gasification of woody residues. This leads to a total 2050 biomethane potential of 95 bm<sup>3</sup> of biomethane by 2050, of which 76 bm<sup>3</sup> will be gas grid transported and 19 bm<sup>3</sup> be supplied per truck as bio-LNG (Terlouw , et al., 2019).

From Navigant's overall energy system analysis, 205 TWh (17.6 Mtoe) of excess electricity would be available by 2050 to produce 200 TWh (17.2 Mtoe) of green hydrogen. To produce power to methane with the same amount of hydrogen, 33 million tonnes of CO<sub>2</sub> is required, which requires, in turn, a raw biogas production volume of 43 bm<sup>3</sup> natural gas equivalent with a CO<sub>2</sub> content of 45% and methane

content of 55%. Assuming a methanation reaction efficiency of 80%. This results in total EU-wide production of 160 TWh (HHV=high heating value, 13.8 Mtoe) of renewable methane from power to methane, or 15  $\text{bm}^3$  of natural gas equivalent in terms of energy density (Terlouw, et al., 2019). The “optimised gas” scenario includes a total renewable methane potential of 1,170 TWh or 110  $\text{bm}^3$ .

- By 2050, about 200 TWh of green hydrogen from curtailed electricity can be supplied for an average cost of 29 €/MWh. In addition, more than 2,000 TWh of green hydrogen from dedicated renewable electricity generation can be supplied for 52 €/MWh. Total green hydrogen demand in various sectors amounts to 1,710 TWh (147 Mtoe) or about 160  $\text{bm}^3$  of natural gas equivalent.
- Hydrogen is a storable energy source that can balance fluctuating demand and enable high shares of intermittent renewable electricity sources. Hydrogen can also provide inter-seasonal storage, both of which are needed in a net-zero energy system.
- For green hydrogen production to satisfy the total hydrogen demand by 2050, the relevant policy framework must be in place as early as possible in order to foster implementation.

### Soil organic carbon sequestration

The production of sustainable biomethane can enable a business case for sustainable agriculture. To produce feedstock for their anaerobic digesters, a group of 600 Italian farmers, organised in the Italian Biogas Consortium (CIB), have developed the concept of growing a sequential crop after their annual (food or feed) crop. This ensures that the soil is covered almost throughout the year, which reduces loss of organic carbon by erosion and the need of mineral fertiliser. This sequential (cover) crop is fed into an anaerobic digester, together with animal manure and food waste, and the remaining digestate is brought back into the soil, directly or after application of SYSTEMIC technologies as shown in this project. Among other nutrients, this practice brings back organic carbon to the soil. This Biogas-Done-Right (Dale, et al., 2016) concept has demonstrated an increase in soil fertility, water retention properties, and a reduction of erosion. Due to the sequestration of additional carbon into soils, the agriculture sector can also make a noteworthy contribution in decarbonising and compensating part of their hard-to-abate nitrous oxide and methane emissions.

### Role of renewable gas in the energy mix

The contribution of gaseous (hydrogen and biomethane) energy carriers, electricity and other energy types to an optimised gas EU-2050 scenario is shown in table 4.1. Biomethane and hydrogen together contribute 2882 TWh (248 Mtoe), power 4461 TWh (384 Mtoe) and other carriers 1669 TWh (144 Mtoe) - solar, wind and hydropower not included.

Table 4.1 Allocation of gas, electricity and other energy carriers in the “optimised gas” scenario in 2050 (in TWh) (Terlouw, et al., 2019)

Sector	Biomethane	Hydrogen	Electricity	Other
Buildings (heating)	185	46	399	396
Industry (iron & steel, ammonia & methanol, cement & lime)	69	627	286	484
Transport (road, shipping, aviation)	595	252	772	534
Electricity consumption in other sectors	-	-	3,004	-
Power*	322	786	-	254
<b>Total</b>	<b>1,171</b>	<b>1,711</b>	<b>4,461</b>	<b>1,669</b>

\* Demand of biomethane, hydrogen and other describe the fuel use in the power sector. This does not include energy input from variable renewable electricity generation, like solar, wind, and hydropower.

The “Gas for Climate 2050” study includes forecast estimations of the feedstock cost which is shown in table 4.2. The forecast assigns a cost to all considered feedstock types, even to manure and other low value organic substrates (sewage sludge is not included), hence the real cost could be lower than calculated in this study. However, as shown by the real business cases analyses in this study, it cannot be excluded that in the end operators of digesters would have to pay for most substrates.

Table 4.2 Estimated cost per feedstock type (Terlouw , et al., 2019)

Feedstock category	Feedstock type	Feedstock cost 2050 (€/tonne-dry matter)
<b>Sequential crops</b>	Triticale, wheat, or ryegrass silage	78
<b>Agricultural residues</b>	Cereal crop residues	47
	Oil crop residues	47
<b>Biodegradable waste<sup>213</sup></b>	Manure	5-50
	Barks	92
<b>Woody residues</b>	Branches and tops	92
	Early thinnings	92
	Landscape care wood	92
	Road side verge grass	92
	MSW	12
<b>Residual and post-consumer waste</b>	Wood waste	12

Estimated CAPEX and OPEX figures for biogas plants and gas upgrading units are shown in table 4.3. The cost data for a typical 500 m<sup>3</sup>/h biogas plant was provided by the Consorzio Italiano Biogas (CIB, <https://www.consorziobiogas.it>) whereas the costs for the upgrading facility were obtained from the Biosurf study (Sternberg, et al., 2016, [www.biosurf.eu](http://www.biosurf.eu)). The production costs in the decentralised scenario are estimated to be € 57/MWh. The grid injection and connection costs are about € 2.8/MWh and € 1.9/MWh (assuming 1 km steel pipes), respectively while the costs for biogas pipelines are estimated to be at € 5/MWh.

Table 4.3 CAPEX and OPEX for anaerobic digestion (Terlouw, et al., 2019)

Technology	Plant size (m <sup>3</sup> /h)	CAPEX	OPEX	Biomethane yield
		(M€)	(M€/yr)	(m <sup>3</sup> /t DM)
Anaerobic digestion	500	5.86	0.60	Feedstock specific
Anaerobic digestion	1000	9.89	0.63	Feedstock specific
Anaerobic digestion (upgrading unit only)	1000	2.00	0.11	NA

### Forecast 2050 demand for electricity and gas in a “minimal gas” and “optimised gas” scenario

The “minimal gas” and “optimised gas” scenarios both require a large increase in renewable electricity. Also, full decarbonisation of high temperature industrial heat requires a share of renewable gas in both study scenarios. Yet significant differences between both scenarios exist. In the “optimised gas” scenario, existing gas infrastructure is used to transport and distribute 1,170 TWh (100 Mtoe) renewable methane and 1,710 TWh (147 Mtoe) hydrogen to the EU buildings, industry, transport, and power sectors. This corresponds to a 2050 gas consumption of 272 billion cubic metres of natural gas equivalent (in terms of energy). The “minimal gas” scenario assumes that gas infrastructure would be mostly decommissioned and flexibility in the electricity system will be either provided by expensive solid biomass power or even more expensive battery seasonal storage. Battery storage remains expensive compared to gas grid storage, even if battery costs go down to € 60,000/MWh of storage capacity by 2050. It should be noted that renewable methane use is supply-driven whereas hydrogen use is demand driven. Furthermore, hydropower and liquid biofuel are supply-driven and direct electricity consumption throughout the energy system is demand driven.

Figure 4.11 below illustrates the supply and demand of renewable and low-carbon gas in the “optimised gas” scenario. Subsequently, the allocation of energy to demand sectors is described for both scenarios.

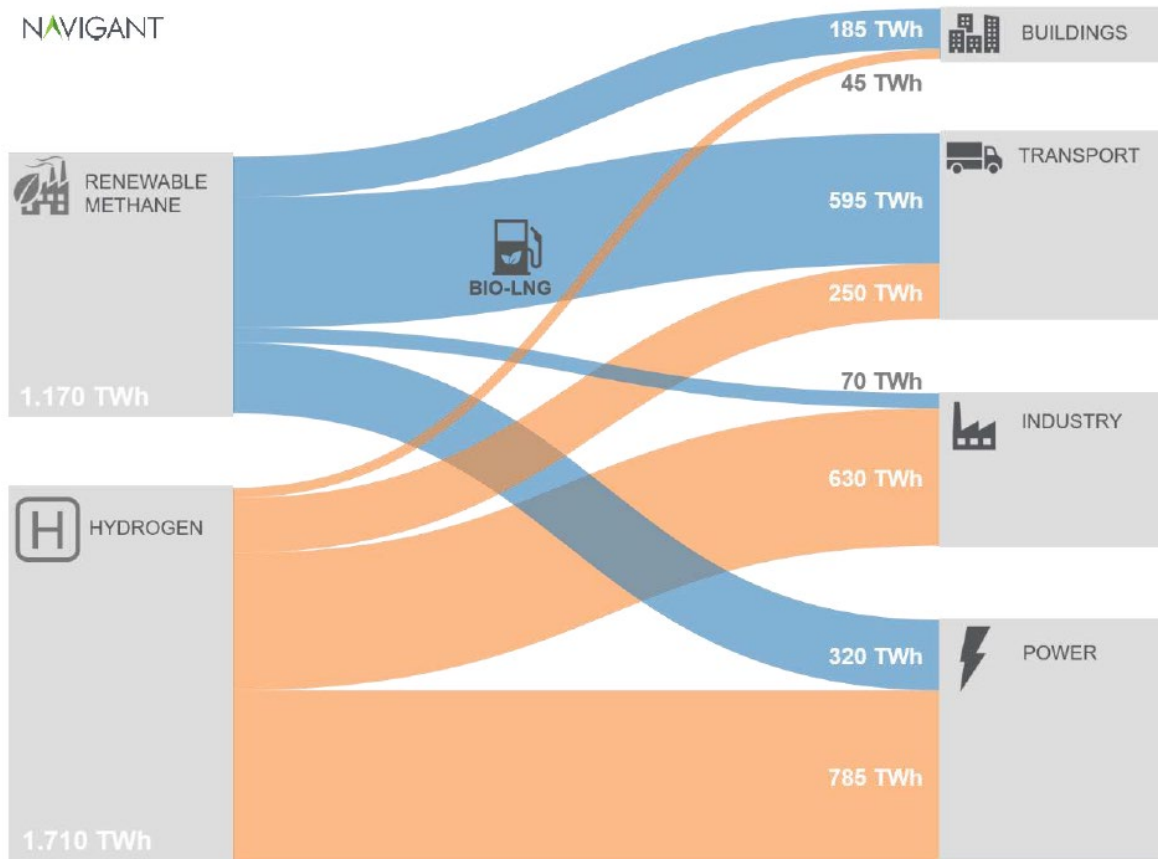

Figure 4.11 Renewable and low-carbon gas supply and demand in the "optimised gas" scenario (Terlouw, et al., 2019)

### 4.3 Conclusions from economic framework evaluation

A large number of current studies has been reviewed to evaluate the economic framework for SYSTEMIC business cases from the perspective of the current and future (projected EU-2050 low and net zero GHG emissions) EU policy and regulatory framework: (EBA, 2016), (EBA, 2018), (Eichhammer, Herbst, Pfaff, Fleiter, & Pfluger, 2018), (European Commission, 2018), (European Commission, 2017), (European Commission, 2018), (Frank, et al., 2018), (International Energy Agency (IEA), 2019), (IRENA, 2019), (Kampman, et al., 2016), (Kovacs, 2015/1), (Masson-Delmotte, et al., 2018), (Observ'ER (FR), 2018), (Scarlat, Dallemand, & Fahl, 2018), (Sternberg, et al., 2016), (Terlouw, et al., 2019), (Tsao, Lewis, & Crabtree, 2006), (UNFCCC, 2015), (WWFF Briefing Paper, 2019), (van Melle, et al., 2018).

Virtually all studies have a role for biogas and biomethane in future, low or zero-carbon energy mixes. Project developers and investors should know that in all eight scenarios considered by the European Commission include a relevant share of 7-10% of biomethane and e-gases in the final energy mix, on par with natural gas and highly relevant for industry and transport fuels, particularly for long-haul heavy good vehicles. Biomethane can be easily blended with natural gas and gradually substitute natural gas for all gas purposes in which gas is used as chemical building block and as transport fuel, including CNG and LNG. Biomethane options allow the use of the existing gas grids and of readily available gas fuelling stations in certain European Member States.

Since the European Communication COM(2018) 773 final lays out the policy framework for the current and future European energy policies and is embeded in a series of energy related Directives (Directive 2014/94/EU, Directive (EU) 2018/2001 and Directive (EU) 2018/2002) that will govern legislation in Member States, at least for the next decade, the framework for investments in and operations of biogas plants should be quite stable and more harmonised in the near future.

The focus on the energy related framework was chosen due to the nature of SYSTEMIC business cases to be evaluated. Essential revenues of five out of six cases come from energy sales. Nutrient recovery and recycling (NRR) is in most cases highly relevant for operations but direct sales of nutrient recycling products contribute only marginally to the profit & loss statement of the operating companies. Currently, a promising biogas plant project could only be developed on the basis of relevant incomes from energy sales – with only few exceptions where gate-fees for substrate are the main cash-flow contributors. Even in cases where gate-fees are high, a relevant income from energy sales must be considered as a robust business case back-up in case the substrate supply market changes.



# 5 Business case evaluation - approach and methodology

One task of SYSTEMIC is to evaluate business cases of demonstration and outreach plants and derive key performance indicators and business models for other plants.

For this purpose, operators of demonstration and selected outreach plants were approached with a structured questionnaire asking for an individual business case description. This description had to include relevant financial figures to make the business case understandable. Individual business case descriptions are available in Annexes 1-6.

The questionnaire was discussed with the plant operators in face-to-face meetings and several question and answer rounds. Some questions and the corresponding answers may seem to be redundant due to having been addressed in WP1. However, in contrast to the technical process context in WP1, here the subjects were discussed in the business case context. This holds particularly true for the SWOT analyses where specific properties like strengths and weaknesses were assessed by their relevance for the single business case with an attempt to facilitate a comparison between the plants and to show how certain strengths or weaknesses are connected to a more or less positive financial result.

The disclosure of usually confidential financial data was a major issue and subject to extended discussions. Finally, a format was agreed allowing the reader to understand the business cases without disclosing all operational details of the plant so that all six project participants gave their consent to publication. However, including outreach plants that do not participate in the project and consequentially don't benefit from the H2020 grant did not agree to disclose their business case. The WP1 team was able to study the cases but was not allowed to publish the results. Since NRR had no or only limited roles in the investigated cases, refraining from publication has no influence on the evaluation of biogas and NRR related businesses.

Due to the importance of the European policy, regulatory and economic framework in which the anaerobic digestion businesses operate, a complete review of these elements was performed and included in this report. A summary of the results of the framework analysis is given above. All-in-all, one can conclude that large scale biogas plants representative for SYSTEMIC operate in an environment that is expected to be more favourable in the future compared to the current situation. While support schemes were scaled back in some countries during the last couple of years, the pathway towards low or zero-net carbon emissions Europe has taken should be reflected in a rebound of support schemes. This does not mean that some of the SYSTEMIC operators did not find favourable conditions for their business when signing the energy supply contracts five or ten years ago.

Investigations and this report were conceived to provide a biogas focused and easily understandable insight into the business environment and six individual business cases. Authors were trying to make policies and energy supply and consumption patterns and trends understandable – quite a challenging task when operating with eight and more different scenarios, large numbers and different denominators, as well as distinctions between supply and demand numbers, self-consumption by the sector and losses that characterise energy flows in Europe.

## 6 Participating biogas plants

### 6.1 Demonstration plants Overview

**Acqua e Sole S.r.l.**, a thermophilic anaerobic digestion (AD) plant in Vellezzo Bellini (30 km south of Milan), Pavia, Italy, in operation since 2016 with a total annual substrate processing capacity of 85,000 t. Processing municipal sewage sludge and source separated domestic food waste.

*Table 6.1.1 Acqua e Sole Plant characteristics*

Date of commissioning	2016
Annual substrate processing capacity / processed	85,000 t / 72,000 t (62 kt sludge/10 kt food waste)
Installed electric capacity (IEC)	1.6 MW
Installed biomethane capacity	none
Digester volume	13,500 m <sup>3</sup>
Annual biogas output / biogas per t of feedstock	4.0 Mm <sup>3</sup> / 56 m <sup>3</sup> /t
Annual electricity net-output (fed to the grid)	5,547 MWh
Annual bio-methane output	None
Digester type	Thermophilic Continuous Stirred-Tank Reactor (CSTR)
Nutrient recovery & recycling (NRR) facilities	Ammonium recovery system (stripper, scrubber, ancillary equipment)
NRR Products	Hygienised digestate, ammonium sulphate
Framework conditions relevant to the business case	Owners cultivate 1,400 ha agricultural land Low livestock density in the region, dominant crop is rice.

**AM-Power BVBA**, a thermophilic anaerobic digestion (AD) plant in Pittem (40 km west of Ghent), West-Flanders, Belgium, in operation since 2011 with a total annual substrate processing capacity of 180,000 t. Processing biowaste and manure.

*Table 6.1.2 AM-Power Plant characteristics*

Date of commissioning	2016
Annual substrate processing capacity / processed	180,000 t / 171,000 t (150 kt biowaste/21 kt manure)
Installed electric capacity (IEC)	7.5 MW
Installed biomethane capacity	None
Digester volume	20,000 m <sup>3</sup>
Digester type	Thermophilic Continuous Stirred-Tank Reactor (CSTR)
Annual biogas output / biogas per t of feedstock	30 Mm <sup>3</sup> / 170 m <sup>3</sup> /t
Annual electricity net-output (fed to the grid)	34,645 MWh (39,407 MWh <sub>el,tot</sub> + 64,694 MWh <sub>heat</sub> )
Annual bio-methane output	None
Nutrient recovery & recycling (NRR) facilities	Solid/liquid separation by centrifuge; dryer for solid fraction; evaporator and reverse osmosis for liquid fraction
NRR Products	Hygienised, dry, P-rich digestate Hygienised, NK concentrate from liquid fraction Dischargeable (possibly reusable) water
Framework conditions relevant to the business case	High livestock density in the region Products need to be transported to other regions or treated

**BENAS GmbH**, a mesophilic anaerobic digestion (AD) plant in Ottersberg (40 km east of Bremen), Lower Saxony, Germany, in operation since 2006 with a total annual substrate processing capacity of 174,000 t. Processing corn silage, plant residues and poultry litter.

*Table 6.1.3 BENAS Plant characteristics*

Date of commissioning	2006
Annual substrate processing capacity / processed	174,000 t / 102,000 t (82 kt corn & plant residues / 20 kt poultry litter)
Installed electric capacity (IEC)	11.3 MW
Installed biomethane capacity	1,200 m <sup>3</sup> /h
Digester volume	26,000 m <sup>3</sup>
Annual biogas output / biogas per t of feedstock	20 Mm <sup>3</sup> / 194 m <sup>3</sup> /t
Annual electricity net-output (fed to the grid)	26,972 MWh (23,610 MWh <sub>el,tot</sub> + 25,580 MWh <sub>heat</sub> )
Annual bio-methane output	8,78 Mm <sup>3</sup> (1,200 m <sup>3</sup> /h)
Digester type	Thermophilic Continuous Stirred-Tank Reactor (CSTR)
Nutrient recovery & recycling (NRR) facilities	FiberPlus ammonium stripping system Screw press for solid/liquid separation Rotary drum dryer for digestate
NRR Products	Hygienised dewatered / dry digestate Ammonium sulphate (3,700 t/a) Calcium carbonate (1,000 t/a) Hygienised, dry digestate / fibres
Framework conditions relevant to the business case	Biogas storage capacity 39,000 m <sup>3</sup> Owners cultivate 3,500 ha agricultural land, 2,000 ha about 200 km distant from biogas plant Double IEC for full flexibility Desulphurisation gypsum used for ammonium sulphate production FibrePlus system for future production of fibres

**Groot Zevert Vergisting B.V.**, a mesophilic anaerobic digester (AD) plant in Beltrum (35 km southwest of Enschede), Achterhoek Region, Province Gelderland, The Netherlands, in operation since 2004 with a total annual substrate treatment capacity of 135.000 t. Processing manure and biowaste.

*Table 6.1.4 Groot Zevert Vergisting Plant characteristics*

Date of commissioning	2004
Annual substrate processing capacity / processed	135,000 t / 120,000 t (90 kt manure / 30 kt biowaste)
Installed electric capacity (IEC)	6.5 MW
Installed biomethane capacity	None, biogas is directly sold to FrieslandCampina
Digester volume	15,000 m <sup>3</sup>
Annual biogas output / biogas per t of feedstock	10 Mm <sup>3</sup> / 75 m <sup>3</sup> /t
Annual electricity net-output (fed to the grid)	3,200 MWh (5,000 MWh <sub>el,tot</sub> )
Annual biogas output	6,5 Mm <sup>3</sup>
Digester type	Thermophilic Continuous Stirred-Tank Reactor (CSTR)
Nutrient recovery & recycling (NRR) facilities	GENIAAL – flotation, microfiltration, reverse osmosis RePeat – acidification and struvite reactors
NRR Products	Mineral NK concentrate Struvite, P-depleted organic product
Framework conditions relevant to the business case	High livestock density in the region Products need to be transported to other regions or treated

**RIKA Biofuels / Green Create W2V Ltd.**, a mesophilic anaerobic digester (AD) at Fridays' Knoxbridge Farm, Frittenden, Cranbrook, Kent, United Kingdom, currently under construction with a total annual substrate treatment capacity of 60,000 t. Planned to process poultry litter and straw.

*Table 6.1.5 Rika Biofuels / Green Create W2V Plant characteristics*

Date of commissioning	2019
Annual substrate processing capacity / to process	60,000 t / 57,500 t (55 kt poultry litter / 2,5 kt straw)
Installed electric capacity (IEC)	1.8 MW
Installed biomethane capacity	450 m <sup>3</sup>
Digester volume	16,000 m <sup>3</sup>
Annual biogas output / biogas per t of feedstock	7.2 Mm <sup>3</sup> / 125 m <sup>3</sup> /t
Annual electricity net-output (fed to the grid)	3,750 MWh (4,125 MWh <sub>heat</sub> )
Annual bio-methane output	2,8 Mm <sup>3</sup>
Digester type	Mesophilic mixed plug-flow digester (system DVO)
Nutrient recovery & recycling (NRR) facilities	N-stripper and reactor Modified dissolved air flotation (DAF) Screw press for solid/liquid separation
NRR Products	Ammonium sulphate Hygienised P-rich digestate
Framework conditions relevant to the business case	Moderate livestock density in the region Products can be used in the region Plug-flow digester

## 6.2 Outreach plant

**A-Farmers / Nurmon Bioenergia Ltd.**, a mesophilic anaerobic digester (AD) in Seinäjoki (80 km southeast of Vaasa), South Ostrobothnia, Finland currently under construction with a total annual substrate treatment capacity of 240,000 t. Planned to process manure, industry by-products and plant biomass.

*Table 6.2.1 A-Farmers / Nurmon Bioenergia Plant characteristics*

Date of commissioning	2021
Annual substrate processing capacity / to process	240.000 t / 210.000 t (90 kt manure, 100 kt industry by products and 20 kt plant biomass)
Installed electric capacity (IEC)	None
Installed biomethane capacity	~20 t of bio-LNG/d
Digester volume	~20 000 m <sup>3</sup>
Annual biogas output / biogas per t of feedstock	15 Mm <sup>3</sup> /50–60 m <sup>3</sup>
Annual electricity net-output (fed to the grid)	-
Annual bio-methane output	9 Mm <sup>3</sup> (90,000 MWh) bio-LNG
Digester type	Mesophilic Continuous Stirred-Tank Reactor (CSTR)
Nutrient recovery & recycling (NRR) facilities	Centrifuges for solid/liquid separation, N-stripper and evaporator
NRR Products	Separated solid fraction of digestate, NPK- (or PK-concentrate and ammonium sulphate)
Framework conditions relevant to the business case	Moderate livestock density in the region All feedstock converted to bio-LNG as a transport fuel

# 7 Business case characteristics

## 7.1 Acqua e Sole

### 7.1.1 Business case with NRR operational

The Acqua e Sole business case is quite special and has not much in common with the other SYSTEMIC demonstration and outreach plants due to

- Not depending on subsidies – electricity is sold at market prices
- 90% of revenues being based on substrate supply based gate-fees and only 10% on energy supplies
- Technically depending on NRR – operating the plant without ammonia stripping is not possible

Table 7.1.1 P & L summary in EUR

<b>Acqua e Sole</b>	<b>Revenues</b>	<b>Expenses</b>	<b>Balance</b>
Substrates (feedstock)	4.536.000		4.536.000
Energy and Green Certificates	306.604		306.604
Product sales / savings *)	0		0
Consumables (chemicals, spare parts)		17.202	-17.202
Digestate & NRR product handling (storage, application)		650.000	-650.000
Operations (personnel, overhead, maintenance, repair)		2.210.000	-2.210.000
Amortisation (15 years)		1.210.569	-1.210.569
	4.842.604	4.087.771	754.833
<b>EBITA (Earnings before interest, amortisation and tax)</b>		<b>1.965.402</b>	<b>EBITA Margin 41%</b>
<b>EBIT (Earnings before interest and tax)</b>		<b>754.833</b>	<b>EBIT Margin 16%</b>

\* Savings of mineral fertilisers: Acqua & Sole in order to valorise nutrients in digestate has agreements with local farmers for mutual exchange of organic fertilisers; so Acqua & Sole does not have accountable savings from chemical fertilizers replacement.

Not depending on public subsidies is positive but it does not necessarily mean that the business case is much less depending on regulation than other SYSTEMIC businesses: the business model requires digested sludge being allowed for application on cropland.

However, only one European country currently prohibits sludge use on cropland: Switzerland. Sweden whose government has launched an enquiry to assess sludge application on agricultural soils and intends to replace this practice by technical nutrient recycling could follow the Swiss example. The European Commission has not shown any signs of stopping the most common nutrient and organic carbon recycling route for sewage sludge. Inorganic pollutants in sludge significantly decreased over time but the concern has shifted towards organic pollutants like hormones, pharmaceuticals and microplastics. More efficient removal of these substances from wastewater will transfer larger fractions to the sludge leading to increased concentrations and potentially calling for restrictions. The medium- and long-term risk for limitations regarding the direct use of digestate on cropland must be considered.

Apart from the risks related to policies and regulations, the risk of restrictions from food industry must also be considered. For instance, in Austria, Germany and Finland, relevant food industry stakeholders prohibit the use of sewage sludge based fertilisers on farmland where contract products, for instance sugar beet, are grown. The interdiction applies to all land where during certain seasons contracted

products are grown due to crop rotation leading to more widespread restrictions than by considering only the area where during one season such products are grown.

On the other hand, Acqua e Sole's digestate products are comparatively low in (measured) inorganic pollutants, including among SYSTEMIC demonstration plants that do not use sewage sludge as a feedstock. Concerns regarding the accumulation of inorganic pollutants in agricultural soils do not seem to be justified. The thermophilic process also reduces pathogens significantly to levels that are considered acceptable by many scientists.

Acqua e Sole has comparatively high operating expenses – reflecting the – compared to the company size and activity – unusual presence of an R&D department with several employees and a pilot plant. Expenses for R&D may not only improve operations and results of the anaerobic digester, but also have an impact on the fertilising products management and crop yields.

The P&L situation of Acqua e Sole is comfortable with earnings before interest and tax (EBIT) in the order of € 750,000 and an EBIT margin of 16%. In contrast to other SYSTEMIC cases, Acqua e Sole does not account the savings for the nutrients used on own farmland due to agreements with farmers that would compensate nutrient needs in case Acqua e Sole would not have sufficient nutrients from its own resources. Consequently, NRR does not directly contribute to the financial result of the plant – in terms of accounting, it reduces the profit. However, without NRR the plant would not be operable in thermophilic mode and the digestate would not be exposed to higher temperatures killing most of the pathogens. Hence, the cost of NRR could be attributed to hygienisation, i.e. a relevant improvement for save use of the digestate. Ammonium sulphate (AS) is a safe mineral product that could contribute to the financial results of the plant if sold to third parties. However, in the form of AS solution it cannot be transported over long distances and possibly not provide relevant market opportunities. The efforts in marketing ammonium sulphate actively may not pay back.

Currently, prices for taking-off sewage sludge tend to rise and further contribute to the profit of Acqua e Sole. Producing bio-methane instead of electricity may be a strategic option for higher earnings from energy – volatile carbon conversion to bio-methane is more efficient and even without additional subsidies bio-methane production could increase Acqua e Sole's profit. This option is favoured by the new Italian renewable energy targets and policies mentioned earlier in this study.

### 7.1.2 Business case before/without NRR

Running the plant with the present substrate mix in thermophilic mode – this was decided for pathogen removal during anaerobic digestion - without nutrient recovery technologies would be inhibiting the conversion of organic matter to biogas after a few weeks due to excessive nitrogen concentration in the digester. A different substrate mix could (partly) solve the problem but would be a different business case. In addition, ammonium sulphate would not be produced and consequently the possibility of adapting the nutrient balance of the fertilising product to crop requirements would not exist. No possibility for future revenue streams from ammonium sulphate

Consequently, the Acqua e Sole business case does not have the option of operating without NRR – it simply would not work.

### 7.1.3 Business case assessment

In conclusion, the business case of Acqua e Sole is highly positive and has a low short-term risk since wastewater treatment plants will continue to produce sewage sludge and are in need for disposal/use routes. The mid- and long-term risk is higher. Larger municipalities may invest in sludge incineration plants. The cost of incineration may be € 60-80, depending on the size of the plant. Sludge incinerators would increase the capacity of disposal routes and possibly reduce the gate-fee for companies like Acqua e Sole. However, if a decision to build a sludge incinerator were taken, for instance in Milan, the plant would not be operational within 5 years from the time of the decision. Such decision, if taken, would leave plenty of time for Acqua e Sole to adapt to a new strategy bringing similar financial results as now.

Table 7.1.2 Acqua e Sole SWOT Analysis

<p><b>Strengths</b></p> <p>Revenues largely based on gate-fee</p> <p>Business not dependent on subsidies</p> <p>A relevant fraction of the organic fertilising product can be used on-site</p> <p>Fertilising product performance can be demonstrated on own farmland</p> <p>Effective nitrogen recovery: Ammonium sulphate can be blended with other end products to tailor-made fertilisers</p> <p>No waste streams</p>	<p><b>Weaknesses</b></p> <p>Sludge management in Italy is regulatory driven and regulations change frequently</p> <p>Currently no relevant revenues from energy conversion</p> <p>No AD without NRR</p>
<p><b>Opportunities</b></p> <p>A relevant CO2 tax may be introduced opening an additional source for revenues.</p> <p>New regulations may offer a new revenue stream from bio-methane conversion</p> <p>If farmers in the vicinity can be convinced of the benefits of the digestate based fertilising products, additional revenues will be generated in the future</p> <p>Marketing and raising awareness may lead to higher revenues for fertilising products</p> <p>High substrate flexibility due to NRR</p>	<p><b>Threats</b></p> <p>The gate-fee for sewage sludge may come under pressure due to alternative disposal routes or more confidence in direct use</p> <p>Revenues largely based on gate-fee</p> <p>Legal or customer restrictions for use of sewage sludge based fertilising products</p> <p>Unforeseeable regulatory changes</p>

Our judgement is that Acqua e Sole has a resilient business case with room for improvement from higher gate fees and/or higher energy borne revenues from bio-methane (bio-CNG/bio-LNG). At least at short-term, almost no downside risk is visible. Upside is provided by the option to produce bio-methane including for transport which will be supported by the Italian government.

## 7.2 AM-Power

### 7.2.1 Business case with NRR operational

The business case of AM-Power is characterised by very high expenses for the feedstock (about 1,750 M€/y) and high expenses for disposal/application of the digestate. The former is determined by the high local competition for substrate having caused the loss of bargaining power to the food industries as main substrate suppliers and having turned an initial gate-fee into a price (currently about € 15/ton of biowaste). The substrate price will not change as long as demand exceeds supply.

In turn, digestate disposal/application costs which were extremely high before the new NRR cascade was implemented (over 2.9 M€/y) have now returned to manageable costs of about 1,25 M€. Apart from some savings on chemicals use and maintenance, NRR makes the difference between a modest profit and high losses. Within the prevailing economic and regulatory framework, NRR is key to turn around the business case of AM-Power.

Table 7.2.1: P & L summary in EUR (forecast, after cascade NRR implementation)

<b>AM-Power</b>	<b>Revenues</b>	<b>Expenses</b>	<b>Balance</b>
Substrates (feedstock)	446.103	2.192.531	-1.746.428
Energy and Green Certificates	7.163.986		7.163.986
Product sales / savings			0
Consumables (chemicals, spare parts)		400.285	-400.285
Digestate & NRR product handling (storage, application)		1.238.984	-1.238.984
Operations (personnel, overhead, maintenance, repair)		1.885.000	-1.885.000
Amortisation (12 years)		1.691.797	-1.691.797
	7.610.089	7.408.597	201.492
<b>EBITA (Earnings before interest, amortisation and tax)</b>		<b>1.893.289</b>	<b>EBITA Margin 25%</b>
<b>EBIT (Earnings before interest and tax)</b>		<b>201.492</b>	<b>EBIT Margin 3%</b>

Due to the current biogas support system in Belgium and the corresponding agreements of AM-Power, revenues from heat and power supply are satisfactory, in the order of 7 M€. The main contribution to the annual revenues stems from "green certificates" at a value of € 100/MWh, covering the whole electricity production and a reasonable bonus for heat use. However, the current legislative framework in Belgium does not leave room for alternative options, for instance upgrading biogas to biomethane. If SYSTEMIC can contribute to convincing political decision makers in Belgium to provide more options for biomass and biogas conversion, AM-Power would have more upside potential. The European Commission has done its homework and published the RED II Directive for a more harmonized European framework for renewable, biomass-based energy.

Among the SYSTEMIC demonstration plants, AM-Power managers have to navigate business in the most challenging environment. The high cost on both ends – feedstock and digestate – seems to be the main problem. NRR solves the problem at one end but cannot contribute anything to the feedstock end. Focusing on negotiations with suppliers and possibly looking for new supply sources could be a promising strategy.

Due to the constraints of using the products in Belgium, even the recycled products do not produce net revenues – because of elevated transport cost. However, similar to the situation in The Netherlands the highest upside potential lies in the products.

If the recycled fertilising products were mineral fertilisers, the market value of the nutrients in the recycled product would come close to 750,000 €, even if modestly calculated at € 500/t for each N, P and K. It is clear that recycled products typically cannot achieve similar sales prices as mineral fertilisers, albeit some examples for customers paying similar or even higher prices exist (e.g. Ostara Nutrient Recovery Inc. for struvite produced from sewage sludge or Magic Dirt potting soil in the US). Companies like Ostara invested heavily in creating a product brand (Crystal Green™) and started selling the product to niche markets. Even if Ostara typically operates in a more favourable environment, they too had to confront real barriers, for instance offering a product derived from sewage sludge. Even if location, quantities produced, risk averseness in Europe and legal framework may provide more constraints for AM-Power than Ostara had to face, the fact that examples of developing a market and demand for recycled products at high prices exist, indicates that looking for niche markets and adapting the product to the requirements of such markets will most likely be the best option for increasing the operational profit of the plant.

However, marketing, sales and application of the recycled materials as chemical product is subject to REACH application. It is expected, that the European Commission will exempt digestate from REACH registration similar to compost (to be published in Qu3/2019) but this exemption will most likely not apply to products derived from digestate.

Another opportunity for higher profits and a more resilient business case may be opened if the definition of "treated manure" in the Nitrates Directive were amended. However, it is still questionable if the NK-



concentrate qualifies as pure mineral fertiliser, which could be exempted from the use restrictions under the Nitrate Directive.

In conclusion, the business case of AM-Power does not fly without nutrient recovery and recycling. On the contrary, the company faced substantial losses before having implemented the upgraded cascade NRR system due to the exorbitant expenses for disposing of the digestate. Like in every region with high livestock density, the key to profitable operations is reducing the quantity of effluents from the plant by solid/liquid separation and by production of N-P-K concentrates with higher nutrient concentrations that can be transported with lower specific costs. The nutrient depleted liquid fraction must be purified to be dischargeable to the sewage system. AM-Power has implemented the most promising NRR system and can hope that the expected performance and corresponding financial results will be achieved.

## 7.2.2 Business case without/before NRR

Disposal of large volumes of raw digestate ( $\pm 150,000$  tons/year) represents an important cost for AM-Power, which could not be handled and disposed of economically because of the competition with manure and digestate from other suppliers in the region.

On top of this, the agro- and food industry in the Pittem area has realized that their waste streams are valuable and started to charge a price to biogas plants for off-taking their waste. Competition between biogas plants makes it difficult to make the business break even.

AM-Power believed that on top of trying to achieve a positive value for the end products, optimizing the process by NRR could balance their business case financially. Among others

- Removing larger parts of water from the digestate, lowering transportation costs
- Lowering the maintenance costs of the existing reverse osmosis (RO) by pre-treatment of the liquid fraction of the digestate by an evaporator
- Using less polymers and chemicals in the centrifuge and skipping the dissolved air flotation (DAF)

Taking into account the impact factors, the comparative headline figures and return profiles for the two scenarios: 'With NRR' and 'Without NRR' are presented below:

Table 7.2.2 EBIT with and without<sup>1</sup> NRR (without NRR corresponds to 2017 operational result)

<b>AM-Power</b>	<b>With NRR in €</b>	<b>Without NRR in €</b>	<b>Difference in €</b>
Substrates (feedstock)	-1.746.428	-1.746.428	0
Energy and Green Certificates	7.163.986	7.163.986	0
Consumables and maintenance	-400.285	-554.264	153.979
Digestate & NRR product handling	-1.238.984	-2.914.403	1.675.419
OPEX	-1.885.000	-1.885.000	0
Amortisation (12 years)	-1.691.797	-1.691.797	
<b>EBIT</b>	<b>201.492</b>	<b>-1.627.906</b>	<b>1.829.398</b>

## 7.2.3 Business case assessment

In conclusion, the business case of AM-Power does not fly without nutrient recovery and recycling. On the contrary, the company faced substantial losses before having implemented the upgraded cascade NRR system due to the exorbitant expenses for disposing of the digestate. Like in every region with high livestock density, the key to profitable operations is reducing the quantity of effluents from the plant by solid/liquid separation and by production of N-P-K concentrates with higher nutrient concentrations that can be transported with lower specific costs. The nutrient depleted liquid fraction must be purified to be

<sup>1</sup> AM-Power had an inadequate NRR system installed that failed to deliver the required results

dischargeable to the sewage system. AM-Power has implemented the most promising NRR system and can hope that the expected performance and corresponding financial results will be achieved.

Table 7.2.3 AM-Power SWOT Analysis

<p><b>Strengths</b></p> <p>Evaporation is an existing, proven technology for digestate</p> <p>Low energy consuming configuration</p> <p>Effective solid reduction: protection of the reverse osmosis (RO) membranes</p> <p>Mineral concentrates, concentrate of evaporator, ammonium water and dried solid fraction can be mixed to form a fertiliser which meets nutrient ratio demands of clients</p> <p>Dischargeable wastewater</p>	<p><b>Weaknesses</b></p> <p>Ammonium water is caustic product (pH 10), which makes it not an attractive fertiliser</p> <p>Mineral concentrate is an unknown product with negative value for farmers at the moment</p> <p>Risk of fouling and clogging of the evaporator during full-scale operations</p> <p>Evaporator does not protect RO from certain oily contamination (volatile fatty acids evaporate)</p> <p>Financial pressure from regional substrate providers (demand exceeds supply)</p>
<p><b>Opportunities</b></p> <p>Ammonium water can be used as reducing agent in (SNCR) DeNOx of exhaust gases or used to improve nutrient ratio of fertiliser blends</p> <p>Sales of high quality dried solid fraction of digestate (custom-made blends)</p> <p>Lower transport costs (less water)</p> <p>Less maintenance costs on RO</p> <p>Possibility of Hygienisation of liquid fraction of digestate in evaporator (needs to be certified)</p>	<p><b>Threats</b></p> <p>Quality of the dischargeable water meeting the discharge limits</p> <p>Scenario of recirculation of mineral concentrates to evaporator needs to be evaluated in practice</p> <p>Flexibility of the process towards future technology developments</p> <p>Unforeseeable regulatory changes</p>

Among the SYSTEMIC business cases, AM-Power's is the most challenging one. Apart from the cost reductions provided by the new cascade NRR system, continuous efforts are needed to reduce costs – e.g. on the feedstock front – or find high priced niche markets for the new recycled products.

## 7.3 BENAS GmbH

### 7.3.1 Business case with NRR operational

The BENAS demonstration plant is a good example for a Circular Economy approach. Currently, all by-products are used to grow the crops fed into the plant and all consumables except fuels for transport are waste products. The minor flaws are land use for energy crop production and the transport distance between the cropland and the biogas plant. The corresponding environmental impact will be shown in the LCA to be performed as task three of WP2. Following the modifications of German legislation, the use of energy crops is gradually replaced by agricultural waste material and poultry litter.

Table 7.3.1: P & L summary in EUR

<b>BENAS</b>	<b>Revenues</b>	<b>Expenses</b>	<b>Balance</b>
Substrates (feedstock)		3.016.626	-3.016.626
Energy and Green Certificates	7.920.373	398.400	7.521.973
Product sales / savings	277.160		277.160
Consumables (chemicals, spare parts)		17.604	-17.604
Digestate & NRR product handling (storage, application)		374.430	-374.430
Operations (personnel, overhead, maintenance, repair)		1.450.000	-1.450.000
Amortisation (12 years)		1.850.000	-1.850.000
	8.197.533	7.107.060	1.090.473
<b>EBITA (Earnings before interest, amortisation and tax)</b>		<b>2.940.473</b>	<b>EBITA Margin 36%</b>
<b>EBIT (Earnings before interest and tax)</b>		<b>1.090.473</b>	<b>EBIT Margin 13%</b>

The BENAS business case is characterized by high substrate costs and high revenues from energy supplies (power and biogas) due to the high tariffs for feeding-in electricity (180 €/MWh) including the bonuses for heat use and flexibility, transferring the control of taking the plant from the electricity grid in case of periodical overload to the local utility.

Biogas which is upgraded to biomethane by the local utility (owning and operating the gas purification plant) almost offsets the substrate cost, both in the order of 3 M€. Electricity contributes almost 5 M€ to the annual revenues. BENAS is prepared for lower feed-in tariffs that may be expected after the expiry of the current contracts: i) the company has invested in large (39,000 m<sup>3</sup>) biogas storage facilities and almost doubled its installed power generation capacity enabling operators to concentrate electricity supplies to periods with high demand and corresponding high electricity prices; ii) the (non-subsidised) revenues from biogas are not much below the revenues from electricity, hence gradually switching energy conversion from power to biomethane does not significantly hamper the business case. However, electricity cannot be fully replaced by biomethane due to the need of heat for NRR which is provided by the highly efficient (>40% conversion efficiency) gas engines.

The direct contribution of NRR is due to savings of mineral fertilisers for growing the energy crops, representing about two thirds of the total feedstock, in the order of 280,000 €. However, indirect savings of NRR by additional power output and savings for processing poultry litter instead of energy crops amount to 950,000 €. Taking the additional CAPEX payback (10 years amortisation) of 521,000 € per year into consideration, net annual savings amount to 713,000 €.

Comparing the current business case with NRR, generating earnings before tax (EBIT) of 1,090,000 € and a satisfying EBIT margin of 13% to a business case without NRR, the EBIT margin would drop to 4%. The current resilience of the business case would be sacrificed, and the positive EBIT margin would be at risk in case of minor cost increases for the substrates.

The most recent recycling development, production of biodegradable, lignocellulosic fibres from digestate, has a high potential for improving the business case. BENAS has proved the concept by supplying fibres for the production of fibreboards but the output of BENAS does not meet the quantitative requirements of fibreboard producers – production is too small for being approved as a regular supplier. More promising are the newest developments like producing biodegradable pots for plants (avoiding the need to remove pots before planting the plants, e.g. in the garden) and producing special papers from the fibres. These products have the potential to improve the business case significantly but require additional marketing efforts and entail higher dependency on third parties.

An – at least theoretical – environmental improvement of the plant could be achieved by replacing the fossil fuel used for transporting raw materials and products by bio-LNG (liquid biomethane) or bio-CNG (compressed biomethane). This would require additional on-site investments to biogas liquefaction or compression. If this would be undertaken, all input materials to any of the plant's flows would be renewable and land use would be the only remaining issue. The corresponding benefits and impacts need to be discussed in the LCA report.

### 7.3.2 Business case without/before NRR

BENAS was an early adopter of nutrient recovery and recycling, starting as early as 2005 with the second digester plant of the company in Ottersberg, subject to this study.

NRR is motivated by two elements: i) the flexibility in selecting different input substrates, for instance replacing energy crops by poultry litter and other organic waste materials ii) the continuous endeavour for improvement in terms of technology, performance and financial results.

Without NRR, BENAS could not replace energy crops by poultry litter (about 20.000 t/year) and would consequentially have to accept a significantly higher cost of substrates and a slightly lower energy yield. In addition, the feed-in tariff would be lower by 20 EUR/MWh due to the missing use of heat that is positively accounted for in the German feed-in tariff scheme. The corresponding savings of CAPEX and OPEX do not compensate the income losses. More than 713.000 EUR of annual earnings would be sacrificed without nutrient recovery as shown in the table below.

Table 7.3.2 Financial results with and without NRR in EUR (only items with differences)

<b>BENAS</b>	<b>With NRR in €</b>	<b>Without NRR in €</b>	<b>Difference in €</b>
Electricity output	4.855.000	4.220.000	635.000
Cost of substrates	-3.017.000	-3.339.000	322.000
Fertiliser replacement	277.000	0	277.000
CAPEX		-521.000	-521.000
<b>EBIT (Earnings before interest and tax)</b>	<b>1.090.473</b>	<b>360.000</b>	<b>713.000</b>

### 7.3.3 Business case assessment

In conclusion – BENAS represents a resilient, closed loop business case that partly owes its highly attractive EBIT margin to the current feed-in tariff and bonuses.

Table 7.3.3 BENAS SWOT Analysis

<p><b>Strengths</b></p> <ul style="list-style-type: none"> <li>High percentage of substrate produced on own farmland</li> <li>All products can be used on own farmland</li> <li>High flexibility in energy conversion, preparedness for regulatory changes</li> <li>Robust, proven NRR technology</li> <li>Only recycled chemicals needed</li> <li>Low OPEX</li> <li>Fibre rich digestate can be recycled to               <ul style="list-style-type: none"> <li>- Ammonium sulphate solutions (ASL)</li> <li>- Lime</li> <li>- Cellulosic fibres suitable for replacement of wooden biomass</li> </ul> </li> </ul>	<p><b>Weaknesses</b></p> <ul style="list-style-type: none"> <li>No treatment of liquid digestate to dischargeable water</li> <li>Potentially higher CAPEX (filter press, 3-4 stripping vessels)</li> <li>Dependency on energy crops</li> </ul>
<p><b>Opportunities</b></p> <ul style="list-style-type: none"> <li>Fibre production for sustainable fibre products with high value in Future</li> <li>Higher substitution of energy crops by organic waste products</li> </ul>	<p><b>Threats</b></p> <ul style="list-style-type: none"> <li>Unforeseeable regulatory changes</li> <li>Fluctuation of energy prices</li> </ul>

However, the deeper analysis shows that even under a less favourable legal framework, BENAS would convert biomass to bioenergy and generate revenues for its owners. A certain supplement for biomass-based, fully flexible energy supplies compared to volatile sun- or wind-based power should of course always be provided by policy makers, but this is anyway foreseen in the different strategic options investigated by the European Commission in the EU-2050 low or net zero carbon scenarios.

## 7.4 Groot Zevert Vergisting

### 7.4.1 Business case with NRR operational

The Groot Zevert business case is one of only two cases in SYSTEMIC allowing a direct comparison of operations with and without nutrient recovery and recycling. The plant was operated without NRR until 2018 and only from 2019 the NRR systems GENIAAL and RePeat, jointly developed by GZV, Nijhuis Industries and Wageningen Research have been installed and operated. In contrast to other SYSTEMIC demonstration plants, the GZV plant can be operated without nutrient recovery and recycling without changing the feedstock or operational parameters.

Table 7.4.1 P & L summary in EUR (2020 forecast incl. NRR)

<b>Groot Zevert Vergisting (GZV)</b>	<b>Revenues</b>	<b>Expenses</b>	<b>Balance</b>
Substrates (feedstock)	780.000		780.000
Energy and Green Certificates	3.348.000	108.000	3.240.000
Product sales / savings	14.400		14.400
Consumables (chemicals, spare parts)		992.000	-992.000
Digestate & NRR product handling (storage, application)		449.800	-449.800
Operations (personnel, overhead, maintenance, repair)		546.000	-546.000
Amortisation (12 years biogas plant / 5 years NRR)		1.560.000	-1.560.000
	4.142.400	3.655.800	486.600
<b>EBITA (Earnings before interest, amortisation and tax)</b>		<b>2.046.600</b>	<b>EBITA Margin 49%</b>
<b>EBIT (Earnings before interest and tax)</b>		<b>486.600</b>	<b>EBIT Margin 12%</b>

The sources of revenues amounting to 4,142 million Euro are quite balanced between gate-fees (0.78 million Euro), biogas supplies to the dairy factory FrieslandCampina (2.6 million Euro) and power supplies to the grid (0,75 million Euro). FrieslandCampina is located just about 2 km from the Groot Zevert biogas plant. Because of the revenue mix and the direct supply of biogas to the dairy plant the dependence on subsidies is lower than for comparable plants.

The downside of the relevant gate-fees for manure are high costs for the digestate – by far the single largest cost position of the base-case amounting to 2,38 million Euro. It is quite obvious that plant owners selected this cost position to improve the business case due to paying € 22.00 for each of the 108,000 tons of digestate that needs to be disposed of.

The solutions aim at significantly reducing the amount of raw digestate which needs to be disposed of by transportation to Germany over distances of 200-300 km. In a first step (GENIAAL), the raw manure is separated to water, a liquid N-K concentrate and a mineral rich, solid organic fertilising product. Water discharge and application of the liquid N-K concentrate cost much less than managing raw digestate because it can be discharged to surface water and used (N-K product) in the vicinity of the plant. The remaining 20,000 tons of solid organic fertilising product still have a similar disposal cost as the raw digestate, but the quantity has been reduced to 1/5 of the original amount and the cost to about 1/3 (0.78 million Euro).

The second step aims at fractionating the remaining 20,000 tons (at least a large part of it) to P-depleted organic soil improver, struvite and a liquid residual stream with a high gypsum content. The step almost halves the cost of handling and discharging the remaining effluents and reduces the effluent mass flow further. The second step is not yet designed to treat the whole amount of solid effluents, hence leaves room to unlock additional savings potential during later stages.

As can be seen in the tables, direct revenues from recycled products don't have a relevant impact on the business case. Currently, the focus is on reducing the costs. However, GZV pursues a strategy for selling the recycled products to selected niche markets like designing the nutrient (P) depleted solid organic fraction for use as potting soils. GZV management has also realised that developing products for acceptance and demand by determined players needs extra efforts and has a cost – partly covered by SYSTEMIC. Even if this insight does not look like a major milestone it must be emphasized due to only few recyclers paying attention to product marketing and due to the almost total absence of public funding for this purpose.

In the business case of GZV, revenues from recycled products should still have a substantial upside potential. If the fertilising products could be sold at prices anywhere near to the current market prices for nutrients in mineral fertilisers, only the 2,400 t/a of struvite could generate some 400,000 Euro per year. Similar revenue potentials may be hidden in the N-K concentrate and the P-depleted organic fraction, if it can be sold as potting soil. However, any application of the recycled materials as chemical product (in contrast to remaining waste) will require REACH application. It is expected, that the European Commission will exempt digestate from REACH registration similar to compost (to be published in Qu3/2019) but this exemption will most likely not apply to products derived from digestate.

However, revenue potentials would only materialise if targeted marketing actions are taken. The cost of marketing a new product may be equal to or even exceed CAPEX and OPEX of producing the recycled product. The supplier may be requested to advertise the new product, to employ field advisers directly talking to farmers, to provide storage facilities close to the areas where the product will be applied and similar marketing, sales and logistics provisions. Hence, marketing the recycled products to higher value markets may improve the business case but also has the potential to drive GZV to expenses that do not generate a relevant return.

#### 7.4.2 Business case analysis without/before NRR

Revenues remain largely unchanged due to low expectations regarding prices for recycled products (struvite, N-K+S concentrate).

*Nutrient recovery and recycling have a significant impact on the disposal/application cost of digestate: starting from a cost of € 2,376,000 it is reduced to € 781,000 after operating GENIAAL and to € 449,800 after operating RePeat. The operational savings are achieved by additional investments of € 1,478,000 for the GENIAAL system and € 1,697,000 for the fully integrated NRR system.*

Table 7.4.2 Comparison of expenses/revenues in EUR – base case, NRR with GENIAAL and NRR with RePeat in EUR

<b>Groot Zevert Vergisting (GZV)</b>	<b>Base Case without NRR</b>	<b>NRR GENIAAL</b>	<b>NRR GENIAAL+ RePeat</b>
Disposal/application of solid digestate (after NRR)			-381.000
Disposal/application of digestate and products (after NRR)		-781.000	-17.600
Disposal/application of solid fraction and N-K concentrate (NRR)			-51.200
Disposal/application of digestate (before NRR)	-2.376.000		
Human resources costs	-240.000	-240.000	-240.000
Maintenance & consumables	-360.000	-360.000	-360.000
Amortisation (biogas plant, 12 years)	-900.000	-900.000	-900.000
Electricity consumption	-108.000	-108.000	-108.000
GENIAAL / RePeat fixed costs (amortisation, personnel)		-870.000	-966.000
GENIAAL / RePeat variable costs (maintenance, consumables)		-518.000	-632.000
<b>Expenses</b>	<b>-3.984.000</b>	<b>-3.777.000</b>	<b>-3.655.800</b>
Revenues from energy sales	3.348.000	3.348.000	3.348.000
Revenues from gate-fees	780.000	780.000	780.000
Revenues from fertiliser product sales			14.400
<b>Revenues</b>	<b>4.128.000</b>	<b>4.128.000</b>	<b>4.142.400</b>
<b>EBIT (Earnings before interest and tax)</b>	<b>144.000</b>	<b>351.000</b>	<b>486.600</b>

### 7.4.3 Business case assessment

GZV is operating the plant in a challenging environment with nutrient supplies exceeding the sustainable demand, reflected in relevant gate-fees but also in very high costs for digestate disposal and application.

Table 7.4.3 Groot Zevert SWOT Analysis

<p><b>Strengths</b></p> <ul style="list-style-type: none"> <li>Revenues/no cost from substrate</li> <li>Contracted sales of biogas to nearby customer</li> <li>All products can be used within the nearby region.</li> <li>50% of the water in digestate can be discharged to surface water.</li> <li>Comparatively simple process design</li> </ul>	<p><b>Weaknesses</b></p> <ul style="list-style-type: none"> <li>Comparatively high investments in nutrient recovery installations.</li> <li>First of its kind NRR-installation</li> <li>The quality and stability of the product is not yet well defined including the fate of sulphate.</li> <li>Agronomic parameters (Nitrogen uptake efficiency) of produced N-based fertilisers are not yet determined</li> </ul>
<p><b>Opportunities</b></p> <ul style="list-style-type: none"> <li>Use of (blends of) NK concentrates as an alternative for synthetic fertiliser.</li> <li>Use of organic matter (fibres) as an alternative for peat in potting soil or as soil improver on arable land.</li> <li>Use of recovered mineral (Mg~P or Ca~P) as a secondary resource for the P fertiliser industry.</li> <li>Emerging awareness in EC around manure status could open the possibility for applying mineral recovered nutrient end products &gt;170kg N/ha/year in nitrate vulnerable zones as "mineral fertiliser".</li> </ul>	<p><b>Threats</b></p> <ul style="list-style-type: none"> <li>Risks associated with implementing new and innovative technologies</li> <li>Fertilisers regulation: can the P fertilizer industry use the recovered mineral P as source to produce P-fertilisers.</li> <li>Dependency on local dairy producer</li> <li>Unforeseeable regulatory changes</li> </ul>

The challenge has been addressed by installing a comprehensive nutrient recovery and recycling system consisting of two units called GENIAAL and RePeat, the former referring to the liquid fraction and the latter to the solid fraction after mechanical separation. The business case evaluation shows that the NRR systems improve earnings before interest and tax (EBIT) by more than 200% and make the business case more resilient.

## 7.5 RIKA Biofuel / Green Create W2V

### 7.5.1 Business case analysis with NRR operational

The Green Create W2V business case represents a completely new project, developed and implemented under the current regulatory framework of the UK. This means green certificates or feed-in tariffs that are much closer to market prices than previous contracts, requiring very efficient, competitive biomass-to-energy solutions and favouring conversion to biomethane.

While looking out for attractive business opportunities suitable for RIKA Biofuel's anaerobic digestion solutions, the team identified large amounts of poultry litter that were not in the focus for conversion to biogas due to its high nitrogen content inhibiting conversion in standard Continuous Stirred-Tank Reactor (CSTR) anaerobic digesters. After the British government finally has agreed on the legal and economic framework for biomass-based renewable energy, RIKA started to develop the project based on converting poultry litter and straw to 900 m<sup>3</sup>/h of biogas, most of which (670 m<sup>3</sup>/h) being upgraded to biomethane and 230 m<sup>3</sup>/h converted to electricity to cover the heat and power requirements of the plant and feed-in to the grid the subsidised – albeit small - fraction.

Table 7.5.1 P & L summary in EUR (according to business plan, operations at full capacity)

<b>RIKA Biofuels / Green Create W2V</b>	<b>Revenues</b>	<b>Expenses</b>	<b>Balance</b>
Substrates (feedstock)	372.333		372.333
Energy and Green Certificates	3.503.444	197.000	3.306.444
Product sales / savings	273.750		273.750
Consumables (chemicals, spare parts)		303.700	-303.700
Digestate & NRR product handling (storage, application)		650.000	-650.000
Operations (personnel, overhead, maintenance, repair)		483.666	-483.666
Amortisation (20 years)		759.250	-759.250
	4.149.527	2.393.616	1.755.911
<b>EBITA (earnings before interest, amortisation &amp; tax)</b>		<b>2.515.161</b>	<b>EBITA Margin 61%</b>
<b>EBIT (earnings before interest and tax)</b>		<b>1.755.911</b>	<b>EBIT Margin 42%</b>

The expected 4.15 M€ of total revenues are based on revenues from biomethane supplies (3.2 M€), power supplies (0.3 M€), gate-fees (0.37 M€) and fertilising product sales (0.27 M€). If all assumptions hold true, it is the most profitable business case due to three out of four in- and outflows producing revenues and modest operations and maintenance costs.

Nonetheless, revenues largely depend on biomethane (77%) and power (7%) supplies contributing 84% to the total revenues. Regardless of upgrading the digestate-based fertilising products to N-P-K concentrate and ammonium sulphate, handling and application (outsourced to a fertiliser contractor) of these products still exceeds the sales revenues by more than a factor two.

Notwithstanding the considerable recycling product handling and sales costs, the business case is highly profitable and produces a remarkable ROI of 15.6% and an EBIT margin of 42%. It is also highly resilient, if biomethane supplies produce the projected revenues. Currently, the price of biomethane is still subsidised but under future scenarios with higher prices for fossil fuels and a relevant CO<sub>2</sub> tax imposed, the price may come much closer to market prices.





The business case remains profitable regardless of operating the plant with or without NRR, although running the plant without NRR would be meaningless. The digester is designed for stripping nitrogen and producing a N-P-K concentrate and would not have been built without the corresponding features. In case of not receiving gate-fees for the feedstock or in case of not achieving revenues from product sales, the business case would still be profitable. In addition, a contingency is foreseen in the business plan in case of certain parameters not meeting the design values.

Similar to the other SYSTEMIC business cases, profits could still be significantly enhanced by closing the gap between the market price of nutrients in conventional fertilisers and the market value of recycled fertilisers.

Figure 7.1 Magic Dirt™ potting soil product from digestate

Magic Dirt™ (<https://www.magic-dirt.com/>), a potting soil produced exclusively from DVO's digestate in the USA and sold by Walmart in 2,500 outlets is an excellent example for how a digestate-based product could be marketed.

Magic Dirt™ is formulated with anaerobically digested organic fibre and composted forest products. It is not compost, and it contains no peat moss, coir, perlite or vermiculite. The products are certified under the USDA's BioPreferred Program as 100% BioBased (all organic ingredients). This does not mean that the product would be accepted for organic farming in Europe, but it may be a very viable pathway for achieving a high market value – the retail value in the US is about 700 USD/ton.

The barriers for producing products like Magic Dirt™ from SYSTEMIC demonstration plants are most likely the number of supply sources and the homogeneity of products – DVO has more than 120 similar plants using mainly cow manure as feedstock and consequently producing a large quantity of a quite homogenous product. Walmart and blenders would probably not be interested to start such an activity with only one source of supply. But as soon as a project pipeline would demonstrate growing potential, similar business cases should be possible in Europe.

## 7.5.2 Business Case without NRR

Running a 100% poultry manure plant without nutrient recovery technologies would be a concept Rika would never attempt due to the risk of creating a vast water requirement and a huge effluent issue that could not be managed economically. However, in an attempt to quantify the benefits of using the NRR technologies on this project. RIKA has run some scenarios attempting to quantify what would be the revenue and cost impacts of not using NRR. The main influencing factors on the business case would be as follows:

1. No revenue stream for separate fertilizer products; high P digestate and ammonium sulphate
2. Much higher water usage to dilute incoming manure, adding cost
3. Cost of disposing of large quantities of effluent/liquid digestate
4. Reduced capex from NNR install costs not being utilized
5. Reduction in polymer and sulphuric acid usage

Taking into account the impact factors, the comparison headline figures and return profiles for the two scenarios are presented: 'With NRR' and 'Without NRR'

Table 7.5.2 Business case with and without NRR

<b>RIKA Biofuels / Green Create W2V</b>	<b>With NRR in €</b>	<b>Without NRR in €</b>	<b>Difference in €</b>
Revenues from energy, gate-fees, NRR	4.149.527	4.000.000	-149.527
Digestate disposal (application)	650.000	1.800.000	-1.150.000
Consumables (chemicals)	303.700	200.000	103.700
Operations	483.666	450.000	33.666
Amortisation (20 years)	759.250	311.250	448.000
<b>EBIT</b>	<b>1.755.911</b>	<b>1.041.750</b>	<b>-714.161</b>

### 7.5.3 Business case assessment

Table 7.5.3 Green Create W2V SWOT Analysis

<p><b>Strengths</b></p> <ul style="list-style-type: none"> <li>Simple, robust NRR design</li> <li>Low CAPEX for NRR</li> <li>Low OPEX</li> <li>No moving parts within Digester</li> <li>Revenues from input and output</li> <li>All products are used in the vicinity</li> <li>Up to 99,9% pathogen removal</li> <li>High input flexibility</li> </ul>	<p><b>Weaknesses</b></p> <ul style="list-style-type: none"> <li>US technology solution that must be implemented for the first time in Europe</li> <li>No AD without NRR</li> </ul>
<p><b>Opportunities</b></p> <ul style="list-style-type: none"> <li>Sale of high quality, nutrient rich, pathogen free digestate and ammonium sulphate</li> <li>Added value through packaging digestate from the plug flow reactor design that is not available to CSTR technologies</li> </ul>	<p><b>Threats</b></p> <ul style="list-style-type: none"> <li>Total dependency on local poultry farm</li> <li>Unforeseeable regulatory changes</li> </ul>

Conclusively, the RIKA Biofuel and Green Create W2V demonstration plant shows that by providing a stable economic and regulatory framework with relatively modest incentives, highly profitable business cases could be developed and effectively contribute to a stable renewable energy supply, a transport fuel for heavy duty vehicles with low or zero greenhouse gas emissions and production of recycled fertilising products that reduce the environmental burden of livestock farming.

## 7.6 A-Farmers / Nurmon Bioenergia

### 7.6.1 Business case analysis with NRR operational

Since the Nurmon Bioenergia SYSTEMIC outreach plant is not yet in operation, the P&L calculation is based on the forecast for 2022, the first year in full operation. Key revenue flows have been already confirmed by pre-contracts - required by shareholders and banks - with suppliers (feedstock) and customers (LBG).

The business case of the biogas plant of Nurmon Bioenergia is driven by two factors: i) the good perspectives for bio-LNG (liquid biomethane) for heavy duty transportation in Finland with bio-LNG politically being considered as an adequate replacement for fossil fuels for long distance transport and ii) the abundant availability of organic feedstock from livestock farming and the food industries. Both factors are pillars of the business case, but bio-LNG is by far outweighing gate-fees from feedstock. Local

livestock farmers supplying manure, covering close to 50% of the organic plant feed, do not pay gate-fees like in the Netherlands and other European regions where livestock density is still considerably higher than in the Seinäjoki region where the plant is located. However, food industry supplying by-products to the plant pays gate-fees and contributes almost 1 M€ to the revenues of the plant.

Table 7.6.1 Profit & Loss summary (2022, full operation) in EUR

<b>A-Farmers / Nurmon Bioenergia</b>	<b>Revenues</b>	<b>Expenses</b>	<b>Balance</b>
Substrates (feedstock)	1.010.000	652.400	357.600
Energy and Green Certificates	8.100.000	1.372.080	6.727.920
Product sales / savings			0
Consumables (chemicals, spare parts)		1.035.326	-1.035.326
Digestate & NRR product handling (storage, application)			0
Operations (personnel, overhead, maintenance, repair)		1.575.000	-1.575.000
Amortisation (10 years)		3.450.000	-3.450.000
	9.110.000	8.084.806	1.025.194
<b>EBITA (Earnings before interest, amortisation and tax)</b>		<b>4.475.194</b>	<b>EBITA Margin 49%</b>
<b>EBIT (Earnings before interest and tax)</b>		<b>1.025.194</b>	<b>EBIT Margin 11%</b>

Bio-LNG contributes about 8 M€ and is the source for the profitability of the plant, despite the high CAPEX of about 10 M€ related to purification and liquefaction of the biogas. Already signed pre-contracts with energy customers confirm that the required price of some 90-100 € per MWh for bio-LNG is achievable. The pre-contracts provide the solid financial basis for the project.

The products from NRR are separated to a solid fertilising product fraction, N:P concentrate to be used as fertilising product or as nutrient carrier for (industrial) wastewater treatment plants and to water that is dischargeable to sewage plants. Currently, none of these products is considered to directly contribute to the revenues of the plant – operators cannot forecast a relevant price for the digestate-based products, even if the N:P concentrate is needed by pulp and paper mills. However, separating the liquid fraction and making it dischargeable is key to the commercial viability of the plant with estimated savings of 0.5–1.0 M€ per year compared to the EBIT of slightly above 1 M€ per year.

The Nurmon Bioenergia business case demonstrates the prevailing trends for biogas, at least in Nordic countries: production of liquid biogas or compressed biogas as renewable fuel for trucks operating in transnational or transcontinental transport, requiring extended autonomy of up to 1600 km per tank. Bio-LNG can replace diesel without causing any inconvenience for the logistics sector: using the existing infrastructure, essentially the same diesel engines and being able to drive long distances without tank stops. Comparable services by electric trucks are not yet available and possibly never will be. Biogas to bio-LNG conversion is more efficient than conversion to power and the commercial value of bio-LNG or bio-CNG is higher.

## 7.6.2 Business Case without NRR

The planned biogas plant would not be feasible without nutrient recovery. The main problem would be digestate storage capacity: 150,000 – 200,000 m<sup>3</sup>/year almost corresponding to the total annual digestate production.

The estimated storage, transport and application cost of the produced digestate would amount to 875,000 to 1,750,000 €/year if one realistically assumes an average cost of 5 – 10 €/m<sup>3</sup>. CAPEX and OPEX savings could not compensate the excessive storage and application cost.

The net savings of nutrient recovery are estimated at 0.5 to 1 million €/year.

### 7.6.3 Business case assessment

If all assumptions hold true, Nurmon Bioenergia will demonstrate a profitable, resilient, waste and industrial by-product based business case with a clear function in the future energy mix and an easy transition pathway, to which truck manufacturers like Iveco, Scania and Volvo have already adapted by offering bio-LNG trucks with the same performance as diesel trucks but with much lower GHG or even negative (for the manure derived bio-LNG fraction) impact.

Table 7.6.2 Nurmon Bioenergia SWOT Analysis

<p><b>Strengths</b></p> <ul style="list-style-type: none"> <li>Animal manure is a well available raw material</li> <li>Revenues from gate-fee</li> <li>No costs from digestate disposal</li> <li>Evaporation is an existing, proven technology for digestate</li> <li>Dischargeable wastewater</li> <li>Products can be used regionally</li> </ul>	<p><b>Weaknesses</b></p> <ul style="list-style-type: none"> <li>No gate-fees available from manure, dependency on energy prices</li> <li>Low amount of gas fuelled cars and bio-LNG using trucks, market development rate?</li> <li>Additional storage capacity due to fertiliser use limitations</li> </ul>
<p><b>Opportunities</b></p> <ul style="list-style-type: none"> <li>Animal manure is very low utilised resource so far &gt; possibility to copy concept in Finland and provide demonstration plant for technology suppliers with international interest</li> <li>Recycled nutrient products are suitable for organic farming which is an increasing sector</li> <li>Potential for increasing bio-LNG use</li> <li>Additional revenues from recycled products</li> </ul>	<p><b>Threats</b></p> <ul style="list-style-type: none"> <li>Fluctuation of energy prices</li> <li>Low price of LNG, customers readiness to pay enough extra for bio-based fuel</li> <li>Unforeseeable regulatory changes</li> </ul>

In conclusion, Nurmon Bioenergia demonstrates an example for conversion of waste biomass to gas which seems to have the potential for several similar projects, at least in Nordic countries. However, the pathway taken by Nordic countries may serve as a good example for other European member states for efficient use of waste-based biofuels with low environmental impact. The transition from diesel to bio-LNG does not require high infrastructure investments and can be implemented right away – in several European Member States an almost adequate fuelling infrastructure already exists.

# 8 Nutrient Recycling Potential

## 8.1 Current benefits of nutrient recycling

The current benefit of all nutrient recycling and recovery systems (NRR) is related to the selection of feedstock materials (Acqua e Sole, BENAS) and/or, even more so, the handling of the digestate. Apart from the digester type and operations limiting certain feedstock combinations (for instance poultry litter with high N concentration), the installed NRR systems aim at reducing the cost of handling the digester effluents. In regions with elevated livestock density and corresponding limitations to the use/disposal of digestate, or other constraints like nitrate vulnerable zones or climatic conditions limiting the use of digestate, it is too costly to store, handle and transport digestate (with >90% water). Hence, it is more profitable to invest in NRR technologies than coping with the corresponding high operational costs.

Apart from two plants, AM-Power and Groot Zevert Vergisting, the SYSTEMIC demonstration- and the participating outreach plant have been conceived and operated with nutrient recovery and recycling systems as operations without NRR would not be viable – commercially and technically. Hence, NRR is an integrated part of four of the six investigated business cases and to abstract NRR is only hypothetically feasible for Acqua e Sole, BENAS, RIKA Green Create W2V and A-Farmers – Nurmon Bioenergia.

In terms of comparison, the business case of Groot Zevert is most transparent. The plant operated with a profit, albeit a moderate one, before the NRR systems were installed in 2018/2019. The NRR systems GENIAAL™ and RePeat™, developed in cooperation with Nijhuis Industries and Wageningen Research aim at reducing the mass flow of the liquid and the solid effluents of the digester whereas the nutrients being concentrated and made suitable for export. They are installed stepwise and increase the profit by roughly 200,000 € (GENIAAL) in the first step and by about 150,000 € (RePeat) in the second step. The example clearly shows the business benefits of NRR.

None of the techniques has so far generated tangible profits from product sales – all benefits are due to reduced costs, mainly because of lower mass flows. The benefits of NRR range from several hundred thousand to more than 1.5 million Euro, even if the AM-Power case may look very optimistic. Proven, accountable benefits range in all cases where monetarisation is possible, between 300,000 and 700,000 Euro.

In short

- 2 demonstration plants have been operational without (Groot Zevert) or with non-adequate NRR systems (AM-Power) and installed a new system in the course of the SYSTEMIC project which allows a direct comparison “before” and “after”.
- 3 demonstration and one outreach plant(s) would not produce biogas from the given substrate mix without NRR and would need to re-design the plant or at least change their mode of operation without NRR: Acqua e Sole, BENAS, Green Create and Nurmon Bioenergia. In these cases, benefits of NRR are substantial, derived from substrate mix, biogas conversion efficiency and digestate use.

## 8.2 Untapped potentials from NRR

Globally and in general, nutrient recovery and recycling has focused on recovery by reducing the OPEX of facilities. This holds true for NRR from wastewater where currently, apart from a few exceptions, only struvite plants with low recovery efficiency are operational (more than hundred plants in Europe, North America and Japan). And it holds true for most of the agricultural NRR activities as SYSTEMIC business demonstrate.

However, there are also a few examples of making a business of the recycled products: Ostara Nutrient Recovery Inc. (Vancouver, Canada) has demonstrated how to create a top brand product (Crystal Green™, <https://crystalgreen.com/>) (Ostara Nutrient Recovery Inc., 2019) out of struvite and DVO Inc. (Chilton, WI, USA) (DVO Inc., 2019), in cooperation with two innovative project developers (Bob Joblin and Ted Sniegocki) has proven that the digestate treated by NRR technologies can serve as a building block for potting soil, Magic Dirt™ (<https://www.magic-dirt.com/>) (Magic Dirt, 2017), currently sold by 2.500 Walmart outlets in the US. Magic Dirt™ is a bagged potting soil that has been certified as 100 percent biobased by the USDA's BioPreferred Program and was initially approved for use in organic production by the Idaho Department of Agriculture." The product is also certified as a premium potting soil by the Mulch and Soil Council.

Magic Dirt™, introduced in the spring of 2014, is a blend of nutrient-rich digested (mainly cattle-)manure and other recycled natural materials that has a pH within the 6-7 range and a guaranteed analysis of 1.15% Total N, 0.30% available phosphate and 0.35% soluble potash, 6- to 10-times the nutrients found in other brands of premium potting soil (hence, high nutrient content sold as an advantage). It is packaged in 1 cu.ft. (28 litres) bags and distributed to garden centres and big box retailers in most states. Apart from making use of the solid, fibrous, hygienised fraction of the digestate, it replaces peat. The use of peat in potting soils is associated with high greenhouse gas emissions, some 6,000 t of methane per hectare of peat harvested (Magic Dirt, 2017). Magic Dirt™ is a perfect example for the Circular Economy and for upcycling the product – its retail price equivalent is about 700 USD/t. The manufacturing company is now located in Little Rock (AR), also named Magic Dirt and it has 5 manufacturing facilities in the US.



Figure 8.1 Crystal Green™ struvite from sewage sludge

Figure 8.2 Magic Dirt™ potting soil from dairy digestate



From studying the history of products like Crystal Green™ and Magic Dirt™ one can learn that it takes time and money to develop branded products from the recycling materials. Interestingly, this kind of development happens mainly in the US and it seems to be a flaw of the European economy that the combination of risk averseness and lack of risk capital does not favour the development of branded products.

Actually, none of the SMEs having specialised in developing circular solutions has focused on product development – nearly all efforts and funds went into developing technical solutions. However, some good examples exist also in Europe, where for instance Aquaminerals B.V., Nieuwegein, The Netherlands (<https://aquaminerals.com/>) (Aquaminerals B.V., 2019), a company founded and owned by the Dutch Waterboards develops products from recycled materials from wastewater treatment plants.

It is therefore recommended to develop product design and marketing plans including the following elements:

- i. Identifying market niches that could absorb the – possibly adapted – products in terms of quantity and quality (quantity also means, that the addressed market is not by orders of magnitude larger than the supply potential which may lead to low interest due to the irrelevance of alternative offers);
- ii. Identifying relevant actors in the market niche;
- iii. Calculating the total market size in terms of quantity and value, the total addressable market (TAM) and the serviceable market (SAM) and the obtainable market (SOM);
- iv. Contacting potential customers and getting a relevant feedback;
- v. Developing a strategy and work plan for introducing the envisaged product to the market and
- vi. Calculating the estimated cost of introducing the new product to the market.

Developing branded products and associated business plans would be a good business opportunity for innovative agricultural service products. In the US, Ostara had initially focused on turf and golf course markets (due to the high magnesium concentration, struvite is being beneficial for grass) and step-by-step developed other markets, always following research about which plants/crops would particularly benefit from the elements contained in the product.

In turn, Magic Dirt has focused on the garden market, a segment that has shown strong growth and is perfectly compatible with desired scenarios enhancing biodiversity and lower greenhouse gas emissions.

In conclusion: developing branded products from recycling materials is an untapped potential that could significantly enhance the profitability and even the environmental impact (like for instance by replacing peat as building block for potting soils) of agricultural activities.

Some of the demonstration plants are making early steps in the product development direction. As mentioned, the business and finance framework in Europe does not support product development, partly due to not providing finance for product and market development. Frequently, the investments in time and cash are underestimated – examples show that 3-5 years of continuous efforts including a dedicated and experienced team are needed until a product brand can be established. Policy efforts are needed to provide a more favourable economic and financial framework.

## 9 Business case evaluation conclusions

Revenues of anaerobic digestion plants are largely driven by revenues from energy supplies, mainly governed by feed-in tariffs/premiums and energy related support schemes. Investors looking for business opportunities assess the availability of digestible feedstock and the conditions for constant energy supplies – in the form of electricity, biomethane or bio-LNG/CNG as transport fuel. This has motivated the authors to first evaluate future, low or net zero energy scenarios for the presence of biogas-derived energy. The critical question was if the European Commission and other relevant stakeholders have biogas in their forecast energy scenarios?

The clear answer is “yes”: policy, legal and economic frameworks are favourable to the development of anaerobic digestion projects with nutrient recovery and recycling. Indeed, all eight strategic EU-2050 options for a low or net zero carbon economy, developed by the European Commission and based on a large number of scientific and practitioner expert contributions include biogas and its derivatives as an essential element of the 2050 energy mix with a supply share of 7-10%. Hence, biogas and particularly biomethane are supposed to have a market and Member States are supposed to redesign their support schemes to comply with the CO<sub>2</sub> emission targets. Despite the fact that solar and wind power will have the dominant role in energy supplies, gas and gas-based fuels will be needed for certain industry applications and for non-energy related purposes such as chemical building blocks. After having verified that the technology will not become obsolete in a foreseeable future, the actual SYSTEMIC business cases were evaluated.

SYSTEMIC business cases are anaerobic digestion plants in rural areas, with annual sales in the order of 4-9 million Euro by converting organic waste from different origins and some energy crops to biogas, electricity and biomethane (including bio-LNG) and producing different organic and inorganic products, mainly for use in agriculture.

Despite revenues being largely determined by revenues from energy (typical for the sector, with only one exception), nutrients and soil nutrient status prove to be a key factor when evaluating the strengths and weaknesses of AD business cases. Where nutrients are in oversupply (frequently because of high livestock density), operating an anaerobic digestion business in the financial comfort zone is much more difficult than operating it in a region where the nutrient situation is balanced. High amounts of manure in supply frequently result in lower profits for digestion plants – independently from feed-in tariffs or other framework conditions. The two cases with comparatively lowest profitability are in Flanders and the Netherlands, the regions with the highest livestock densities among regions covered by SYSTEMIC. In one case, the digester business is under pressure from both sides: it should pay for the organic/nutrient rich feedstock and for disposing the effluents, mainly due to powerful industrial substrate suppliers that exploit the comparatively weak position of the digester business. This weakness needs to be further addressed in the course of the project.

Nonetheless, all SYSTEMIC business cases demonstrate that nutrient recovery and recycling as an additional service adds value to the mainly energy driven business case. In all six investigated cases nutrient recycling improves the financial result of the enterprise – apart from the obvious social and environmental benefits like long-term, qualified jobs in rural areas and abatement of greenhouse gases. The cash contributions from nutrient recycling are substantial – between a few hundred thousand to more than a million Euro per case. Nutrient recycling does not depend on support schemes – the cash benefits do not depend on subsidies, increase profits and reduce the dependency of biogas plants on support schemes.

Investigating five demonstrations and one outreach plant and overviewing several additional outreach plants that have joined the project has proven that nutrient recycling, if done properly, is a net cash contributor to the business. However, plants that do not expect net benefits will not invest in nutrient recycling as long as their business is profitable without. This was demonstrated by an additional AD plant operator in Ireland, whose business was evaluated but no consent was given to publish the results in the report.

An overall conclusion can be drawn in that a biogas plant located in an area with low livestock density, large cropping/pasture areas, mild climate (allowing longer and possibly more than one agricultural



cycle(s)) and low nitrate sensitivity (no nitrate vulnerable zone), a biogas plant may not need to have its digestate treated to make good use of it. However, attention should be paid to the potential presence of pollutants and pathogens in digestate that still may require some of the nutrient recycling technologies. In addition, the cash flow potential of nutrient recycling technologies should always be assessed in terms of its benefits to the individual business case: it may allow a more profitable selection of feed substrates (e.g. replacing energy crops by poultry litter, as demonstrated by SYSTEMIC) and a less costly digestate handling.

A significant untapped upside potential lies in the development of "upcycled", branded products from the effluents of the digester. Some best practice cases are reported as a role model for being studies and – in case of being promising – developed during the remaining two years of SYSTEMIC.

In short, the conclusions of the business case evaluations are:

- All business cases, after NRR implementation, are profitable and more profitable than before
- Generate annual revenues between 4.1 and 9.1 M€
- Generate annual EBITs between 200,000 and 1.8 M€ with an EBIT margin between 3% and 42%
- All implemented NRR systems are technically mature and perform in compliance with design specifications
- NRR systems contribute substantially to the financial results of the plants because of enabling higher biogas output or reducing digestate volume and associated handling and transport costs
- In contrast to NRR systems, recycled products contribute only marginally to the revenues – there is a high potential for improvement by developing branded products which are in demand by (niche) agricultural or non-agricultural markets like gardening
- RED II transposition to national legislation may entail potential for higher EBT from bio-methane and bio-LNG/CNG in the future.

# 10 References

- Aquaminerals B.V. (2019). *Aquaminerals*. Von <https://aquaminerals.com/home/> abgerufen
- Dale, B., Sibilla, F., Fabbri, C., Pezzaglia, M., Pecorino, B., Veggia, E., . . . Bozzetto, S. (2016). *Biogasdoneright™: An innovative new system is commercialized in Italy*. *Biofuels, Bioprod. Bioref.* 10: 341–345 (2016): Society of Chemical Industry and John Wiley & Sons, Ltd, DOI: 10.1002/bbb.1671.
- DVO Inc. (2019). *DVO renewables at work*. Retrieved from <http://www.dvoinc.com/>
- EBA. (2016). *Biomethane in Transport*. Brussels: European Biogas Association.
- EBA. (2018). *Statistical Report of the European Biogas Association 2018*. Brussels: European Biogas Association 2018.
- Eichhammer, W., Herbst, A., Pfaff, M., Fleiter, T., & Pfluger, B. (2018). *Impact on the Environment and the Economy of Technological Innovations for the Innovation Fund (IF)*. Brussels: European Union.
- European Commission. (2017, 10. 20). *Clean Energy for all Europeans package*. Retrieved from Clean Energy for all Europeans package: <https://ec.europa.eu/energy/en/topics/energy-strategy-and-energy-union/clean-energy-all-europeans>
- European Commission. (2018). *COMMUNICATION FROM THE COMMISSION TO THE EUROPEAN PARLIAMENT, THE EUROPEAN COUNCIL, THE COUNCIL, THE EUROPEAN ECONOMIC AND SOCIAL COMMITTEE, THE COMMITTEE OF THE REGIONS AND THE EUROPEAN INVESTMENT BANK*. Brussels: European Commission, COM(2018) 773 final.
- European Commission. (2018). *IN-DEPTH ANALYSIS IN SUPPORT OF THE COMMISSION COMMUNICATION COM(2018) 773; A Clean Planet for all; A European long-term strategic vision for a prosperous, modern, competitive and climate neutral economy*. Brussels: European Commission.
- European Commission, Press Release Database. (2018). *The Commission presents strategy for a climate neutral Europe by 2050 – Questions and answers*. Retrieved from [https://europa.eu/rapid/press-release\\_MEMO-18-6545\\_en.htm](https://europa.eu/rapid/press-release_MEMO-18-6545_en.htm)
- European Union. (2018). *Statistical Pocket Book*. Luxembourg: Publications Office of the European Union.
- European Union, Parliament and Council. (22. 10 2014). *EUR-Lex*. Von EUR-Lex Directive 2014/94/EU: <https://eur-lex.europa.eu/legal-content/EN/TXT/?uri=celex:32014L0094> abgerufen
- European Union, Parliament and Council. (2018, 12. 11). *EUR-Lex*. Retrieved from EUR-Lex, Directive 2018/2002/EU Energy Efficiency: <https://eur-lex.europa.eu/legal-content/EN/TXT/?uri=celex:32018L2002>
- European Union, Parliament and Council. (11. 12. 2018). *EUR-Lex*. Von EUR-Lex Directive (EU) 2018/2001, Renewable Energy: <https://eur-lex.europa.eu/legal-content/EN/TXT/?uri=celex:32018L2001> abgerufen
- Frank, S., Havlik, P., Stehfest, E., van Meijl, H., Pérez-Domínguez, I., van Dijk, M., & Doelmann, J. (2018). Agricultural non-CO<sub>2</sub> emission reduction potential in the context of the 1.5°C target. . *Nature Climate Change*, pp. DOI: 10.1038/s41558-018-0358-8.
- International Energy Agency (IEA). (2019, 8. 14). *Renewables 2018, Market analysis and forecast from 2018 to 2023*. Retrieved from Renewables 2018, Market analysis and forecast from 2018 to 2023: <https://www.iea.org/renewables2018/>
- IRENA. (2019). *Renewable Power Generation Costs in 2018*. Abu Dhabi: International Renewable Energy Agency, ISBN 978-92-9260-126-3.
- Kampman, B., Leguijt, C., Scholten, T., Tallat-Kelpsaite, J., Brückmann, R., Maroulis, G., . . . Elbersen, B. (2016). *Optimal use of biogas from waste streams*. Brussels: European Commission.

- Kovacs, A. (2015/1). The prospects for biomethane as a road transport fuel in Europe. *MOLGROUP Professional Journal*, S. 42-53.
- Magic Dirt. (2017). *Magic Dirt*. Retrieved from <https://www.magic-dirt.com/>
- Masson-Delmotte, V., Zhai, P., Pörtner, H.-O., Roberts, J., Shukla, P., Pirani, A., . . . Waterfield, T. (2018). *Global Warming of 1.5°C. An IPCC Special Report on the impacts of global warming of 1.5°C above pre-industrial levels and related global greenhouse gas emission pathways, in the context of strengthening the global response to the threat of climate change,*. Intergovernmental Panel on Climate Change (IPCC).
- Observ'ER (FR), E. p. (2018). *THE STATE OF RENEWABLE ENERGIES IN EUROPE, 18th EurObserv'ER Report*. EurObserv'ER Consortium.
- Ostara Nutrient Recovery Inc. (2019). *CrystalGreen*. Retrieved from <https://crystalgreen.com/>
- Scarlat, N., Dallemand, J.-F., & Fahl, F. (28. 3. 2018). Biogas: Developments and perspectives in Europe. *Renewable Energy* 129, S. 457-472. doi:<https://doi.org/10.1016/j.renene.2018.03.006>
- Sternberg, K., Erdmann, G., Kirchmeyr, F., Collins, D., Hofmann, F., Pieroni, C., . . . Scholwin, F. (2016). *Biosurf Fuelling Biomethane - Report on current and future sustainable biomass supply for biomethane production*. Biosurf Fuelling Biomethane.
- Terlouw, W., Peters, D., van Tilburg, J., Schimmel, M., Berg, T., Cihlar, J., . . . Fichter, T. (2019). *Gas for Climate. The optimal role for gas in a net-zero emissions energy system*. Utrecht: Navigant Netherlands B.V.
- Tsao, J., Lewis, N., & Crabtree, G. (2006). *Solar FAQs*. Washington: U.S. Department of Energy, Office of Basic Energy Science).
- UNFCCC. (2015). Paris Agreement. Paris: United Nations.
- van Melle, T., Peters, D., Cherkasky, J., Wessels, R., Rehman Mir, G., & Hofsteenge, W. (2018). *Gas for Climate, How gas can help to achieve the Paris Agreement target in an affordable way*. Utrecht: ECOFYS, SISNL17592.
- WWFF Briefing Paper. (2019). *The EU long term Climate Strategy*. Brussels: WWFF European Policy Office.

# 11 Annex 1 Business Case Evaluation Acqua e Sole s.r.l.



# Business Case Evaluation

---



Acqua e Sole S.r.l., Vellezzo Bellini,  
Pavia, IT

---



## Content

1	Executive Summary .....	III
2	Company Description .....	IV
2.1	Network and Advisors.....	IV
2.2	Products and Services .....	IV
2.3	Benefits and Features.....	V
2.4	Indirect Benefits and Related Activities .....	V
2.5	Long Term Aim of the Business.....	V
3	SWOT Analysis .....	VI
4	Market Analysis .....	VII
4.1	Target Market.....	VII
4.2	Market Trends .....	VII
4.3	Specific Advantages .....	VII
4.4	Stakeholder and Environmental Benefits .....	VIII
5	Marketing/Sales Strategy .....	IX
5.1	NRR Revenue Sources .....	IX
5.2	Pricing .....	IX
6	Research and Development .....	X
7	Staffing and Operations .....	XI
8	Investments and Funding .....	XII
9	Financial Data .....	XIII
9.1	Profit & Loss Summary .....	XIII
9.2	Business Case without NRR .....	XIII
10	Business Case Analysis .....	XIV

# 1 Executive Summary

This business case evaluation covers the thermophilic anaerobic digestion (AD) plant of Acqua e Sole S.r.l. in Vellezzo Bellini (30 km south of Milan), Pavia, Italy, in operation since 2016 with a total annual substrate processing capacity of 85,000 t. Processing municipal sewage sludge and organic waste from source separated domestic food waste.

*Table 1.1 Acqua e Sole Plant characteristics*

Date of commissioning	2016
Annual substrate processing capacity / processed	85,000 t / 72,000 t (62 kt sludge/10 kt food waste)
Installed electric capacity	1.6 MW
Installed biomethane capacity	none
Digester volume	13,500 m <sup>3</sup>
Annual biogas output / biogas per t of feedstock	4.0 Mm <sup>3</sup> / 55 m <sup>3</sup> /t
Annual electricity net-output (fed to the grid)	5,547 MWh
Annual bio-methane output	None
Digester type	Thermophilic Continuous Stirred-Tank Reactor (CSTR)
Nutrient recovery & recycling (NRR) facilities	Ammonium recovery system (stripper, scrubber, ancillary equipment)
NRR Products	Hygenised digestate, ammonium sulphate
Framework conditions relevant to the business case	Owners cultivate 1,400 ha agricultural land Low livestock density in the region, dominant crop is rice.

The selection of feedstock is guided, among others, by the composition of digestate aiming at its nutrient balance and overall fertilising properties. Digestate and ammonium sulphate (AS) solution are used on Acqua & Sole's own farmland (mainly rice) and on farms in the vicinity of the facility. Nutrient recovery was included from the beginning in the form of ammonia stripping and production of ammonium sulphate solution.

Sewage sludge as the preeminent feedstock and it is associated with a significant gate-fee representing a large fraction of the plant's revenues. Its availability is not an issue, on the contrary, Northern Italy faces a shortage of sludge disposal facilities. However, public acceptance of sewage sludge derived fertilisers is a challenge, even after thermophilic digestion and corresponding hygienisation. In response to these barriers, Acqua e Sole has paid much attention and dedicated significant investments to abatement of odours by closed unloading facilities and direct injection into the farmland.

About 1,000 hectares of own farmland enables use and full financial accounting of nutrient value for a significant fraction – about 1/5 - of the digestate. Simultaneously, it allows to demonstrate the benefits of using the organic fertiliser. Closed systems from digestate loading to direct injection into farmland abate emissions, including odours.

The plant is owned by the Natta family and managed by Francesco Natta who is supported by the technical director Andrea Giordano. Apart from a dedicated research and development team (including agronomists) within the company, Francesco counts on the advice of the Department of Agricultural and Environmental Sciences of University of Milano (Fabrizio Adani).

The grandfather of Francesco was the Nobel Prize Winner Giulio Natta (1963). The company mission is to promote sustainable farming practices and innovative solutions for agricultural areas. In this context, environmental services are integrated in agricultural activities in a large rural area. Through re-naturalization of the own area of 1,500 ha, impressive improvements in landscape quality and biodiversity have been achieved.

Acqua e Sole has been financed by private equity. The company's agricultural activities received public support from the European Union within the CAP framework, particularly for re-naturalisation and facilitation of biodiversity.

## 2 Company Description

Acqua e Sole s.r.l. is the operator of anaerobic digestion activity. The approach is, however, different to other biogas plants. The main driver behind the investment was the desire for recycling organic waste flows and particularly urban waste flows to organic fertilisers. The products were designed for use on the own farming area, La Cassinazza, an area of about 1400 hectares and 7 old farmhouses, aiming at restoring biodiversity and achieving high yields. For this purpose, anaerobic digestion was chosen for producing renewable energy used on site and partly fed to the grid and simultaneously offering the opportunity to mix the feedstock for a balanced nutrient composition and eliminating pathogens by thermophilic operations. The business model does not aim at revenues from energy conversion but on closing the nutrient and organic materials loop. Recycling of organic matter was considered of high importance due to the progressing degradation of the peri-urban, industrially managed farmland south of Milano.

The digester is equipped with an ammonium stripping facility enabling the production of an ammonium sulphate solution. For prevention of odour nuisance, the feedstock reception section is provided with locks allowing the unloading of several trucks at once. The digestate delivery system is a closed system enabling the direct filling of tank trucks without any emissions to the environment. Tank trucks go to the fields where the digestate is pumped into trailers or digestate spreading tractors that inject the digestate directly to the soil, again preventing emissions. Hence, the plant is not only operating a nutrient recovery system. It provides all state-of-the-art techniques to produce balanced fertilisers suitable for effective on-farm rice and other crops nutrition and replenishing of organic matter. In addition, it is equipped for avoiding odour nuisance and greenhouse gas emissions. The fully closed system prevents all kinds of losses, including mud on roads and the paved loading and unloading areas.

The agricultural land becomes a new economic and social integration facility, combining respect for the environment and retaining the rural heritage. The experience of the integration of environmental concerns in agricultural production has led to the application of innovative agronomic techniques, including the creation of unmanaged field margins, which are areas important for biodiversity as well as for pollinating insects. The adoption of technical conservation agriculture (CA) and the recovery of rice straw has reduced greenhouse gas emissions.

Apart from the energy activities relevant to SYSTEMIC, Acqua e Sole cares for conversion of solar energy by photovoltaic panels, for conversion of water borne energy by heat pumps and by geothermal energy.

### 2.1 Network and Advisors

Acqua & Sole is supported by the Department of Agricultural and Environmental Sciences of the University of Milano, Fabrizio Adani and his team.

### 2.2 Products and Services

Acqua & Sole is located in an area with some 100,000 ha of arable land of which 85% are used for rice cultivation (A.S.P. 2016) Livestock rearing is not a major activity in the region, only 1.7% of animals reared in Lombardy live in the area, that is about 33,000 out of a total of 32 million. Animal manure is therefore neither an environmental issue, nor an available fertilising material (A.S.P. 2010).

7% of industry and commerce activities in the region deal with food production and organic waste management (A.S.P. 2015). The vicinity of Milano (15 km) with close to 3.3 million people and the food industry are the main sources of feedstock for Acqua & Sole.

Services are consequently focusing on the offtake of organic waste (sewage sludge, food waste) from urban and commercial suppliers. Products are conceived to meet the requirements of sustainable rice cultivation with two applications in mind:



- About 1,000 ha of own farmland;
- About 4,000 ha farmland in the neighbourhood of the plant.

## 2.3 Benefits and Features

- Effective nutrient recovery;
- Balanced nutrient concentration in the digestate product by feedstock selection and ammonia stripping for targeted N management in the products;
- Hygienisation of the digestate by thermophilic digestion, elimination of most pathogens;
- Odour free operations by closed systems and direct injection of digestate;
- As far as own farmland is served, nutrient value can be accounted to 100%.

## 2.4 Indirect Benefits and Related Activities

- Consulting of farmers and SME's towards the introduction of new and more sustainable technologies and processes;
- Using the old farmhouses for commercial activities including housing for start-ups and conferences;
- Developing the whole area and providing jobs and a liveable rural environment preventing young people from moving to the city.

## 2.5 Long Term Aim of the Business

The idea of complementing farming by nature- and social structure conservation practices will be further extended in the region.

- Nature conservation and biodiversity restoration means dedicating a part of farmland – typically 10-15% - to marginal lands, channels, wetlands, forests and hedges as refuge for wildlife and for maintaining a natural balance.
- Social structure conservation means reviving old and partly abandoned rural structures such as farm and animal houses by offering them to start-ups and other entrepreneurial activities like conferences, workshops, etc. preserving the liveability of rural areas and counter the exodus of young and well- educated citizens.

### 3 SWOT Analysis

<p><b>Strengths</b></p> <ul style="list-style-type: none"> <li>• Revenues largely based on gate-fee</li> <li>• Business not dependent on subsidies</li> <li>• A relevant fraction of the organic fertilising product can be used on-site</li> <li>• Fertilising product performance can be demonstrated on own farmland</li> <li>• Effective nitrogen recovery: Ammonium sulphate can be blended with other end products to tailor-made fertilisers</li> <li>• No waste streams</li> </ul>	<p><b>Weaknesses</b></p> <ul style="list-style-type: none"> <li>• Sludge management in Italy is regulatory driven and regulations change frequently</li> <li>• Currently no relevant revenues from energy conversion</li> <li>• No AD without NRR</li> </ul>
<p><b>Opportunities</b></p> <ul style="list-style-type: none"> <li>• A relevant CO<sub>2</sub> tax may be introduced opening an additional source for revenues.</li> <li>• New regulations may offer a new revenue stream from bio-methane conversion</li> <li>• If farmers in the vicinity can be convinced of the benefits of the digestate based fertilising products, additional revenues will be generated in the future</li> <li>• Marketing and raising awareness may lead to higher revenues for fertilising products</li> <li>• High substrate flexibility due to NRR</li> </ul>	<p><b>Threats</b></p> <ul style="list-style-type: none"> <li>• The gate-fee for sewage sludge may come under pressure due to alternative disposal routes or more confidence in direct use</li> <li>• Revenues largely based on gate-fee</li> <li>• Legal or customer restrictions for use of sewage sludge based fertilising products</li> <li>• Unforeseeable regulatory changes</li> </ul>

# 4 Market Analysis

## 4.1 Target Market

The target market for substrates is urban and agro-food industries organic residues, particularly sewage sludge and food industry residues from the urban agglomeration of Milan and Lombardy (about 50% of feedstock) and other parts of Italy (20% from Tuscany and 15% from Piedmont).

The target market for digestate-based fertilising products is farmland (about 1,000 ha) and some 4,000 ha farmland of farmers in the vicinity of the plant, where mainly rice is cultivated (85%). 1,000 ha farmland absorb about 25,000 t of digestate-based fertilising products.

## 4.2 Market Trends

### **Disposal of sewage sludge has become a problem and expensive in Italy.**

- Wastewater treatment plant number is increasing in Italy
- Regulation regarding the direct use of untreated sludge have been tightened and farmers do not trust in the fertilising quality of sewage sludge.
- In addition, the social perception of this practice has become very negative, among others due to odour nuisance and concerns about pollutants and pathogens present in untreated sewage sludge.
- Alternative routes such as sludge incineration could be a problem in Italy because of negative perception of incineration and the high need of organic matter in soils.

These developments are strongly supporting the business model of Acqua e Sole processing urban sewage sludge as main fraction of the substrate mix.

- Future predictions
  - The short- and mid-term trends are still supporting the business case. Some municipalities are now considering incineration, but it will take at least 5 years until we will see the first incineration plants in operation, if they will be built at all.
- Drivers such as demographic changes, economic and legislative factors
  - There are no indications of factors changing the current trend. On the contrary, the trend towards nutrient recycling is fostering the position of Acqua e Sole.
- Implications for the product or service
  - No negative implications are expected in the short and mid-term trends
- Plans to meet future demands and changes in the market
  - Further improving the fertilising product quality for higher and balanced nutrient concentrations and absence of pathogens

## 4.3 Specific Advantages

- Unique features - closed loops for substrate intake and digestate based fertilisers supply and distribution preventing odour and emissions to air;
- Ability to blend ammonium sulphate and produce a more concentrated fertilising product;
- Advanced technologies such as ammonium stripping and production of ammonium sulphate.

## 4.4 Stakeholder and Environmental Benefits

- Closed loops and direct injection complemented with a very high level of professionalism and cleanness are supporting a transformation in the perception of using digestate as a fertiliser;
- The whole set-up of Acqua & Sole as a promotor of sustainable agriculture that use traditional, nature-based systems without sacrificing the agricultural productivity supports the conversion of urban organic waste streams and their use as fertilising product;
- Increase efficiencies
  - A higher NPK product (compared to raw sludge) allows farmers to apply required fertilizers with fewer field passes;
  - At present, all supply chain related services are provided by Acqua e Sole free of charge, costing the company about € 9 per ton of products.

# 5 Marketing/Sales Strategy

- A relevant fraction of the digestate-based fertilising product is used on own farmland and does not require a marketing or sales strategy
- Use and showcase of fertilising products on own farmland aims at convincing farmers in the region to test the products on their farmlands
- Acqua e Sole provides fertilising products free of charge to farmers in the region for testing
- The strategy is consequently marketing and selling the product by convincing the users, preferably farmers in the neighbourhood. During an initial period, users can be attracted by receiving the product at no cost applied to his own farmland

## 5.1 NRR Revenue Sources

Table 5.1 Revenue sources from NRR

	Home country	EU (neighbouring) countries
Products (digestate)	Digestate-based fertilising products for the region	
Services (gate fees)	Gate-fees for substrate supplies from urban / industrial organic waste	
Licences	Supporting cooperation partners and start-ups potentially leading to future license based revenues	The approach and methods may be transferred to other regions including other continents
After sales	Acqua e Sole cares for the total application chain from loading to tank lorries to injecting in farmland soil  Advice to farmers in the region	

## 5.2 Pricing

- After the promotional and investment period (convincing farmers by testing on own farmland and providing bio-based fertilisers free of charge), products will be sold at market price of nutrients
- If a real demand for the products can be evoked, even the transporting and injection services may be charged, saving some € 9/t of fertilising product sold to third parties.

# 6 Research and Development

Acqua e Sole is one of the exceptional farming operations with an own research team of 2-3 employees exclusively working on developing the value chain of:

- Substrate selection
- Anaerobic digestion with nutrient recovery
  - Pathogen removal
  - Ammonium stripping and production of ammonium sulphate
  - Adaption of the fertilising product to the nutrition requirement of rice and other crops cultivated in the region
  - Minimising the emissions associated with the application of the product
  - Application of the fertilising product by direct injection
  - Evaluation of the fertilising value (crop nutrient uptake)
  - Crop health and growth

For the purpose of improving the digester operations, Acqua e Sole has installed a pilot digester on its premises in Vellezzo Bellini.

In addition, Acqua e Sole cooperates with various science institutions, particularly with the Department of Agricultural and Environmental Sciences at the University of Milan.

# 7 Staffing and Operations

## **Management and operational team**

The biogas plant is managed by Francesco Natta and his team:

- Andrea Giordano – Technical Director
- Alfonso Bova – Plant Manager
- Gabriele Geromel – Agronomist
- Marcello Chiodini – Agronomist
- Micol Schepis – Permit/authorisation Manager
- Martina Faccioli – Logistic operator
- Simona Colocresi – Logistic operator
- Sara Panico – Laboratory operator
- N°4 external sources for plant maintenance

## 8 Investments and Funding

Acqua e Sole invested about 22.5 M€ to the anaerobic digester including nutrient recovery and recycling. The investment was comparatively high due to including special provisions for odour abatement (indoor bunker and off-loading area, close piping system including filling stations for digestate, etc.).

The investment was funded from the cash flow of Acqua e Sole's agricultural activities without public grants. No public funding is needed to continue operations and potential expansions of the company.



# 9 Financial Data

## 9.1 Profit & Loss Summary

Table 9.1 P & L summary in EUR

<b>Acqua e Sole</b>	<b>Revenues</b>	<b>Expenses</b>	<b>Balance</b>
Substrates (feedstock)	4.536.000		4.536.000
Energy and Green Certificates	306.604		306.604
Product sales / savings *)	0		0
Consumables (chemicals, spare parts)		17.202	-17.202
Digestate & NRR product handling (storage, application)		650.000	-650.000
Operations (personnel, overhead, maintenance, repair)		2.210.000	-2.210.000
Amortisation (15 years)		1.210.569	-1.210.569
	4.842.604	4.087.771	754.833
<b>EBITA (Earnings before interest, amortisation and tax)</b>		<b>1.965.402</b>	<b>EBITA Margin 41%</b>
<b>EBIT (Earnings before interest and tax)</b>		<b>754.833</b>	<b>EBIT Margin 16%</b>

\* Savings of mineral fertilisers: Acqua & Sole in order to valorise nutrients in digestate has agreements with local farmers for mutual exchange of organic fertilisers; so Acqua & Sole does not have accountable savings from chemical fertilizers replacement.

## 9.2 Business Case without NRR

Running the plant with the present substrate mix in thermophilic mode – this was decided for pathogen removal during anaerobic digestion - without nutrient recovery technologies would be inhibiting the conversion of organic matter to biogas after a few weeks due to excessive nitrogen concentration in the digester. A different substrate mix could (partly) solve the problem but would be a different business case. In addition

- Ammonium sulphate would not be produced and consequently the possibility of adapting the nutrient balance of the fertilising product to crop requirements would not exist
- No possibility for future revenue streams from ammonium sulphate

Consequently, the Acqua e Sole business case does not have the option of operating without NRR – it simply would not work.

# 10 Business Case Analysis

The Acqua e Sole business case is quite special and has not much in common with the other SYSTEMIC demonstration and outreach plants due to

- Not depending on subsidies – electricity is sold at market prices
- 90% of revenues being based on substrate supply based gate-fees and only 10% on energy supplies
- Technically depending on NRR – operating the plant without ammonia stripping is not possible

Not depending on public subsidies is positive but it does not necessarily mean that the business case is much less depending on regulation than other SYSTEMIC businesses: the business model requires digested sludge being allowed for application on cropland.

However, only one European country currently prohibits sludge use on cropland: Switzerland. Sweden whose government has launched an enquiry to assess sludge application on agricultural soils and intends to replace this practice by technical nutrient recycling could follow the example. The European Commission (COM) has not shown any signs of stopping the most common nutrient and organic carbon recycling route for sewage sludge. Inorganic pollutants in sludge significantly decreased over time but the concern has shifted towards organic pollutants like hormones, pharmaceuticals and microplastics. More efficient removal of these substances from wastewater will transfer larger fractions to the sludge leading to increased concentrations and potentially calling for restrictions. The medium- and long-term risk for limitations regarding the direct use of digestate on cropland must be considered.

Apart from the risks related to policies and regulations, the risk of restrictions from food industry must also be considered. For instance, in Austria, Germany and Finland, relevant food industry stakeholders prohibit the use of sewage sludge based fertilisers on farmland where contract products, for instance sugar beet, are grown. The interdiction applies to all land where during certain seasons contracted products are grown due to crop rotation leading to more widespread restrictions than by considering only the area where during one season such products are grown.

On the other hand, Acqua e Sole's digestate products are quite low in (measured) inorganic pollutants, including among SYSTEMIC demonstration plants that do not use sewage sludge as a feedstock. Concerns regarding the accumulation of inorganic pollutants in agricultural soils do not seem to be justified. The thermophilic process also reduces pathogens significantly to levels that are considered acceptable by many scientists.

Acqua e Sole has comparatively high operating expenses – reflecting the – compared to the company size and activity – unusual presence of an R&D department with several employees and a pilot plant. Expenses for R&D may not only improve operations and results of the anaerobic digester, but also have an impact on the fertilising products management and crop yields.

The P&L situation of Acqua e Sole is comfortable with earnings before interest and tax (EBIT) in the order of € 750,000 and an EBIT margin of 16%. In contrast to other SYSTEMIC cases, Acqua e Sole does not account the savings for the nutrients used on own farmland due to agreements with farmers that would compensate nutrient needs in case Acqua e Sole would not have sufficient nutrients from its own resources. Consequently, NRR does not add benefits to the financial result of the plant – in terms of accounting, it reduces the profit. However, without NRR the plant would not be operable in thermophilic mode and the digestate would not be exposed to higher temperatures killing most of the pathogens. Hence, the cost of NRR could be attributed to hygienisation, i.e. a relevant improvement for save use of the digestate. Ammonium sulphate (AS) is a safe mineral product that could contribute to the financial results of the plant if sold to third parties. However, in the form of AS solution it cannot be transported over long distances and possibly not provide relevant market opportunities. The efforts in marketing ammonium sulphate actively may not pay back.

Currently, prices for taking-off sewage sludge tend to rise and further contribute to the profit of Acqua e Sole. Producing bio-methane instead of electricity may be a strategic option for higher earnings from energy – volatile carbon conversion to bio-methane is more efficient and even without additional subsidies bio-methane production could increase Acqua e Sole's profit.

In conclusion, the business case of Acqua e Sole is highly positive and has a low short-term risk since wastewater treatment plants will continue to produce sewage sludge and are in need for disposal/use routes. The mid- and long-term risk is higher. Larger municipalities may invest in sludge incineration plants. The cost of incineration may be € 60-80, depending on the size of the plant. Sludge incinerators

would increase the capacity of disposal routes and possibly reduce the gate-fee for companies like Acqua e Sole. However, if a decision to build a sludge incinerator were taken, for instance in Milan, the plant would not be operational within 5 years from the time of the decision. Such decision, if taken, would leave plenty of time for Acqua e Sole to adapt a new strategy bringing similar financial results.

Our judgement is that Acqua e Sole has a resilient business case with room for improvement from higher gate fees and/or higher energy borne revenues from bio-methane. At least at short-term, almost no downside risk is visible. Upside is provided by the option to produce bio-methane including for transport which is supported by the Italian government.

## 12 Annex 2 Business Case Evaluation AM-Power BVBA



# Business Case Evaluation

---



## AM-Power Pittem

---



## **CONTENT**

1	Executive Summary	III
2	Company Description	V
2.1	Promoters and Shareholders .....	V
2.2	Products and Services .....	V
2.3	Long Term Aim of the Business.....	VI
3	SWOT Analysis	VII
4	Market Analysis	VIII
4.1	Target Market.....	VIII
4.2	Market Trends .....	VIII
5	Marketing/Sales Strategy	IX
6	Research and Development	X
7	Staffing and Operations	XI
8	Investments and Funding	XII
9	Financial Data/Projections	XIII
9.1	Business Case with NRR.....	XIII
9.2	Business Case without NRR .....	XIII
10	Business Case Analysis	XV

# 1 Executive Summary

AM-Power (BE), a mesophilic anaerobic digestion (AD) plant in Pittem (40 km west of Ghent), West-Flanders, Belgium, in operation since 2011 with a total annual substrate processing capacity of 180,000 t. Processing biowaste and manure.

*Table 1.1 AM-Power plant characteristics*

Date of commissioning	2016
Annual substrate processing	180,000 t / 171,000 t (150 kt biowaste/21 kt manure)
Installed electric capacity	7.5 MW
Installed biomethane capacity	None
Digester volume	20,000 m <sup>3</sup>
Digester type	Mesophilic Continuous Stirred-Tank Reactor (CSTR)
Annual biogas output / biogas per t of feedstock	30 Mm <sup>3</sup> / 170 m <sup>3</sup> /t
Annual electricity net-output (fed to the grid)	34,645 MWh (39,407 MWh <sub>el,tot</sub> + 64,694 MWh <sub>heat</sub> )
Annual bio-methane output	None
Nutrient recovery & recycling (NRR) facilities	Solid/liquid separation by centrifuge; dryer for solid fraction; dissolved air flotation (DAF), evaporator and reverse osmosis for liquid fraction
NRR Products	Hygienised, dry, P-rich digestate Hygienised, NK concentrate from liquid fraction Dischargeable (possibly reusable) water
Framework conditions relevant to the business case	High livestock density in the region Products need to be transported to other regions

In 2011 the first biogas production activities started (digestion of organic waste and manure) at the plant of AM-Power. AM-Power is now the largest AD plant (manure and bio-waste) in Belgium.

The plant has an annual treatment capacity of 180 000 tons. The organic waste streams originate from the intensive agro-industrial activities (manure) and associated food industry.

AM-Power generates every year 160 kt of digestate and strives to treat it in a cost effective, efficient and relatively simple way, without losing the nutrients. The plant has developed a technological solution for the recovery of nutrients into valuable fertilizers, which will be further implemented. The current process produces raw digestate and depending if the disposal opportunities are favourable or not, produces a dried solid fraction of digestate, a mineral concentrate (N-K) and relatively clean water, which is used as process water.

The biogas produced every year (including digesters and post-digester) is around 30 Mm<sup>3</sup>. The biogas is converted by a CHP engine into electrical and thermal energy. The amount of heat and electricity produced is respectively 7360 and 7435 kW.

AM-Power is located in the Northern part of Belgium (Pittem) and this region is characterised by an excess of animal manure (having a negative value) and yet a high market demand for formulated synthetic fertilisers. This implies that there is an opportunity for end products with more custom-made nutrient ratios which are closer to the demand of farmers in the region. Yet, these products and application methods remain unknown and therefore not in demand by local farmers. Also, these products are in direct competition with regional surplus of manure (digestate products from manure still have the "manure" status for application) and thus farmers automatically don't want to pay for it, they have a negative market value.

AM-Power is a family business owned by Stefaan Delabie (director). Over the years he has built, started-up and operated two biogas plants in Belgium and one in France.

Henk Dedeyne is his son-in-law. He manages and operates AM-Power and other plants.

Since the commissioning of the plant, Stefaan and Henk have always been experimenting and investing in innovation towards the recovery and recycling of nutrients. They saw them as

valuable elements that should not be destroyed or emitted as N<sub>2</sub> but used for their nutritional value.

The biogas plant and the original nutrient recovery cascade was financed by bank loans, private equity and the ecology premium.

The optimisation of the process by means of adding an evaporator (±2mil €) after the DAF and before the reverse osmosis (RO), will be funded through a combination of

- Funding from the European project SYSTEMIC
- Private investors (Evergaz)



# 2 Company Description

## 2.1 Promoters and Shareholders

- Promoters
  - Stefaan Delabie & Henk Dedeyne
  - Evergaz
- Management structure and areas of responsibility
  - Stefaan Delabie & Henk Dedeyne - Project Developers
  - Evergaz - Funders and Development Support
- Shareholders in AM-Power
  - GLR Group BVBA- Funders and Development Support - 56%
  - Evergaz – Funders and Development Support - 44%
- Advisors
  - Legal- advisors: Advocatenkantoor Lust
  - Technical:
    - Evaporator: K-Révert
    - Optimisation of centrifuge: Zèta
    - Own staff experience
    - United Experts (DLV) – Environmental
    - UGent – research technologies, end products

## 2.2 Products and Services

### **Background to the Current Development**

- Different technology suppliers have been approached to make an offer for the evaporator: France Evaporation, MKR and K-Révert.
- Visits of AM-Power plant owners/managers to existing evaporators on digestate in France.
- Supplier of NRR treatment technologies on digestate (K-Révert) has done some tests with digestate on a demo-evaporator on site at AM-Power and in their lab.

### **Benefits and Features**

- 2 x 3 stage evaporator: lower energy consumption due to configuration of the evaporator and because steam is re-used in different stages.
- Use of residual heat from CHPs (facilitates heat certificates)
- Effective nutrient recovery: estimated 60 % of nitrogen recovered from liquid fraction of digestate in the condensate after evaporation (ammonium water)
- Effective solid reduction: estimated 5 % of dry matter from liquid fraction of digestate ends up in the condensate after evaporation (ammonium water) (DM content 0,4%).
- flexible design to fit into existing NRR cascade

- Hygienisation of liquid fraction of digestate could be possible: a certification entity will test this in the future and certify if the operational conditions (residence time, temperature in the evaporator) meet the regulatory requirements of Hygienisation.

#### **Future Developments**

- Investigating where to mix or re-circulate some end products

## **2.3 Long Term Aim of the Business**

In the next 5 years: Developing a positive business case with nutrient recovery hereby going further in lowering transport volumes and therefore transport costs. This includes, producing as many end products as possible that have a positive market value and can be sold more locally.

### 3 SWOT Analysis

<p><b>Strengths</b></p> <ul style="list-style-type: none"> <li>• Evaporation is an existing, proven technology for digestate</li> <li>• Low energy consuming configuration</li> <li>• Effective solid reduction: protection of the reverse osmosis (RO) membranes</li> <li>• Mineral concentrates, concentrate of evaporator, ammonium water and dried solid fraction can be mixed to form a fertiliser which meets nutrient ratio demands of clients</li> <li>• Dischargeable wastewater</li> </ul>	<p><b>Weaknesses</b></p> <ul style="list-style-type: none"> <li>• Ammonium water is caustic product (pH 10), which makes it not an attractive fertiliser</li> <li>• Mineral concentrate is an unknown product with negative value for farmers at the moment</li> <li>• Risk of fouling and clogging of the evaporator during full-scale operations</li> <li>• Evaporator does not protect RO from certain oily contamination (volatile fatty acids evaporate)</li> <li>• Financial pressure from regional substrate providers (demand exceeds supply)</li> </ul>
<p><b>Opportunities</b></p> <ul style="list-style-type: none"> <li>• Ammonium water can be used as reducing agent in (SNCR) DeNO<sub>x</sub> of exhaust gases or used to improve nutrient ratio of fertiliser blends</li> <li>• Sales of high quality dried solid fraction of digestate (custom-made blends)</li> <li>• Lower transport costs (less water)</li> <li>• Emerging awareness in EC around manure status could open the possibility for applying mineral recovered nutrient end products &gt;170kg N/ha/year in nitrate vulnerable zones as "mineral fertiliser".</li> <li>• Less maintenance costs on RO</li> <li>• Possibility of Hygienisation of liquid fraction of digestate in evaporator (needs to be certified)</li> </ul>	<p><b>Threats</b></p> <ul style="list-style-type: none"> <li>• Quality of the dischargeable water meeting the discharge limits</li> <li>• Scenario of recirculation of mineral concentrates to evaporator needs to be evaluated in practice</li> <li>• Flexibility of the process towards future technology developments</li> <li>• Unforeseeable regulatory changes</li> </ul>

# 4 Market Analysis

## 4.1 Target Market

- Green electricity produced is sold to Luminus (in 2020-2022 to ELINDUS) for 35.15 €/MWh (market price, can fluctuate).
- Digestate is disposed of via local solid fertilizer contractor at a cost of 24 €/tonne (including transport + storage + application on land)
- Dried solid fraction of digestate is sold via direct contacts with end users at 5 €/tonne. In turn, AM-Power pays 18.5 € for transport to France. In the future, the price the end user pay could increase because of the higher nutrient value.

## 4.2 Market Trends

### Future Predictions

- Use of recovered products will become more common practice of local farmers
- Drivers such as economic framework and particularly regulatory constraints
- Pig intensive region will have constant supply of pig manure
- Close to France where nutrients are valued more than in Flanders (no P or N surplus)

Implications for AM-Powers products and services:

- Lower price for digestate: Biogas plants in the neighbourhood will possibly not be able to compete on the digestate/fertiliser market

Plans to meet future demands and changes in the market:

- Optimize fertiliser blending to meet demand of clients or the retail market (e.g. garden centres)
- A marketing/advertising strategy for marketing recycled products within the region needs to be developed

### Competitive Advantage

- Unique features of nutrient blended solid fraction
- Not many biogas plants in the area have installed nutrient recovery and recycling (NRR) technologies or systems
- Able to produce large volumes
- Location close to France

### Benefits to Clients

- Increase efficiencies
  - A higher N-P-K product formula allows farmers to apply required fertilizers with fewer field passes
- Save money
  - Reduced fuel costs for farmers spreading more concentrated products
  - Lower price than conventional fertiliser but with a similar use efficiency

# 5 Marketing/Sales Strategy

- Disposal of digestate by paying a local fertilizer contractor.
- The dried solid fraction (enriched with nutrients) will be sold directly to clients in France.
- AM-Power will explore other higher value opportunities of the enriched solid fraction in year 1 (after the evaporator being operational)
- AM-Power will analyse the clients' needs (nutrient ratios) and try to comply with its recycled products (e.g. blending)

## **Pricing**

- Digestate price is determined by:
  - Market: competition between manure and digestate (number of pig husbandries and biogas plants in the area)
  - Sales experience of local contractors
  - Negotiation with local contractors
- Price for the dried solid fraction is determined by:
  - Nutrient content and transport/spreading costs.
- Price mineral concentrate as fertilisers determined by:
  - Market: competition between manure and digestate
  - Farmers knowledge on the nutrient potential and user-friendliness of the product application compared to other products on the market

## **Marketing and Communications Strategy**

Will be developed after having some operational experience with the new equipment.

# 6 Research and Development

## Technology Roadmap

At AM-Power:

First NRR cascade included a belt press + DAF + reverse osmosis unit

2011: Belt press was replaced, new process chain centrifuges + DAF + reverse osmosis unit

2019: Evaporator is added to configurate a new process chain: centrifuges + DAF + evaporator + RO

## Research and Development

- In-house (at AM-Power and other biogas plants of the group) trial and error process with team of local employees:
  - Selection, testing, finetuning of different of technologies for nutrient recovery and recycling. Testing different process configurations and combinations.
    - Belt press, screw press and centrifuge
    - A belt press appears to work better when the digestate contains a large manure fraction. This is not the case at AM-Power. It also requires a lot of water to keep the belt clean and the capacity was not high enough to process all liquid fraction.
    - Ultrafiltration, Vibratory Shear Enhanced Processing (VSEP) oscillating membranes and reverse osmosis
    - Chamber filter press with lime addition
    - Belt dryer and fluidized bed dryer
- Optimisation efficiency of RO
- Bert Aerts (Zeta),
  - Selection and dosing of polymer in centrifuge and DAF to acquire best separation efficiency
- Henri Van Kaathoven AGMAT,
  - Dosing chemicals and optimization RO
  - Research with UGent (Prof. Verstraete) during the starting period of the plant, on the set-up of the digestate treatment cascade and the optimisation of biogas production

## Technical Partners

1. Anaerobic digester: Bio Dynamics
2. NRR technology:
  - Dryer: TEMA
  - Centrifuge: HILLER
  - DAF: NOVOTEC
  - Evaporator: K-Révert
  - RO: Henry Van Kaathoven (AGMAT)
  - Air washer: Kluizebos

## IP, Patents, Copyrights, Brands

IP is held by various technology and package providers. AM-Power does not hold patents on the implemented technologies.

# 7 Staffing and Operations

## **Management (including Board) Organisation Chart**

- Board: GLR GROUP BVBA represented by Stefaan Delabie.
- The biogas plant is managed day to day by Henk Dedeeyne.

## **Staffing**

- 8 full time operators employed on the site (including holidays and 24/7 coverage)
- CERTAM will manage aspects of the plant's administration and financial reporting.

## **Training Plans**

- The staff receives training on operations of the new evaporator and the modified RO and operates the plant based on previous experience.

## **Operations**

- Premises
  - Address: Brugsesteenweg 176, Pittem, Belgium
- Equipment
  - Biogas plant incorporating:
    - Anaerobic digesters
    - CHP engines
    - Nutrient recovery plant:
      - Centrifuges, dryer, DAF, evaporator, RO, acid air washer
    - Ancillary equipment: truck cleaning, feedstock receiving station, storage

# 8 Investments and Funding

The plant has been built in 2004 and continuously expanded ever since. The accumulated CAPEX is around 20 M€, similar to other SYSTEMIC plants.

The current investment in NRR amounts to about 2.5 M€ with the 2017 budget and the 2019 expenses breakdown as follows:

## Estimation 2017

### Required for:

- Implementation evaporator
  - Evaporator + heat exchangers: ±€ 900.000
  - Fitting evaporator into the existing process: ±€ 540.000
  - Condenser and cooling: ±€ 240.000
- Modification RO: ±€ 120.000

**Total: ±€ 1.800.000**

## Real Costs 2019

### Required for:

- Implementation evaporator
  - Evaporator + heat exchangers: € 1.950.000
  - Fitting evaporator into the existing process: € 200.000
  - Condenser and cooling: ±€ 140.000
- Modification RO: ±€ 150.000

**Total: € 2.440.000**

- Promoters' funds (H2020 SYSTEMIC project): 1.076.950 €
- Bank lending: €0,00
- Investment received as of June 2019: € 523.909,17
- Rest financed by private equity



# 9 Financial Data/Projections

## 9.1 Business Case with NRR

### Profit & Loss Summary (2020 forecast, after NRR installation)

Table 9.1: P & L summary in EUR

<b>AM-Power</b>	<b>Revenues</b>	<b>Expenses</b>	<b>Balance</b>
Substrates (feedstock)	446.103	2.192.531	-1.746.428
Energy and Green Certificates	7.163.986		7.163.986
Product sales / savings			0
Consumables (chemicals, spare parts)		400.285	-400.285
Digestate & NRR product handling (storage, application)		1.238.984	-1.238.984
Operations (personnel, overhead, maintenance, repair)		1.885.000	-1.885.000
Amortisation (12 years)		1.691.797	-1.691.797
	7.610.089	7.408.597	201.492
<b>EBITA (Earnings before interest, amortisation and tax)</b>		<b>1.893.289</b>	<b>EBITA Margin 25%</b>
<b>EBIT (Earnings before interest and tax)</b>		<b>201.492</b>	<b>EBIT Margin 3%</b>

## 9.2 Business Case without NRR

Disposal of large volumes of raw digestate ( $\pm 150,000$  tons/year) represents an important cost for AM-Power, which could not be handled and disposed of economically because of the competition with manure and digestate from other suppliers in the region.

On top of this, the agro- and food industry in the Pittern area has realized that their waste streams are valuable and started to charge a price to biogas plants for off-taking their waste. Competition between biogas plants makes it difficult to make the business break even.

AM-Power believed that on top of trying to achieve a positive value for the end products, optimizing the process by NRR could balance their business case financially.

- Removing larger parts of water from the digestate, lowering transportation costs
- Lowering the maintenance costs of the existing reverse osmosis (RO) by pre-treatment of the liquid fraction of the digestate (evaporator)
- Using less polymers and chemicals in the centrifuge and skipping the dissolved air flotation (DAF)

Taking into account the impact factors the comparative headline figures and return profiles for the two scenarios: 'With NRR' and 'Without NRR' are presented below:

Table 9.2: Revenues with and without<sup>1</sup> NRR (without NRR corresponds to 2017 operational result)

<b>AM-Power</b>	<b>With NRR in €</b>	<b>Without NRR in €</b>	<b>Difference in €</b>
Substrates (biowaste, manure, energy crops)	-1.746.428	-1.746.428	0
Energy and Green Certificates	7.163.986	7.163.986	0
Consumables and maintenance	-400.285	-554.264	153.979
Digestate & NRR product handling	-1.238.984	-2.914.403	1.675.419
OPEX	-1.885.000	-1.885.000	0
Amortisation (12 years)	-1.691.797	-1.691.797	
<b>EBIT</b>	<b>201.492</b>	<b>-1.627.906</b>	<b>1.829.398</b>

---

<sup>1</sup> AM-Power had an inadequate NRR system installed that failed to deliver the required results

# 10 Business Case Analysis

The business case of AM-Power is characterised by very high expenses for the feedstock (about 1,750 M€/y) and high expenses for disposal/application of the digestate. The former is determined by the high local competition for substrate having caused the loss of bargaining power to the food industries as main substrate suppliers and having turned an initial gate-fee into a price (currently about € 15/ton of biowaste). The substrate price will not change as long as demand exceeds supply.

In turn, digestate disposal/application costs which were extremely high before the new NRR cascade was implemented (over 2.9 M€/y) have now returned to manageable costs of about 1,25 M€. Apart from some savings on chemicals use and maintenance, NRR makes the difference between a modest profit and high losses. Within the prevailing economic and regulatory framework, NRR is key to turn around the business case of AM-Power.

Due to the current biogas support system in Belgium and the corresponding agreements of AM-Power, revenues from heat and power supply are satisfactory, in the order of 7 M€. The main contribution to the annual revenues stems from "green certificates" at a value of € 100/MWh, covering the whole electricity production and a reasonable bonus for heat use. However, the current legislative framework in Belgium does not leave room for alternative options, for instance upgrading biogas to biomethane. If SYSTEMIC can contribute to convincing political decision makers in Belgium to provide more options for biomass and biogas conversion, AM-Power would have more upside potential. The European Commission has done its homework and published the RED II Directive for a more harmonized European framework for renewable, biomass-based energy.

Among the SYSTEMIC demonstration plants, AM-Power managers have to navigate business in the most challenging environment. The high cost on both ends – feedstock and digestate – seems to be the main problem. NRR solves the problem at one end but cannot contribute anything to the feedstock end. Focusing on negotiations with suppliers and possibly looking for new supply sources could be a promising strategy.

Due to the constraints of using the products in Belgium, even the recycled products do not produce net revenues – because of elevated the transport cost. However, similar to the situation in The Netherlands the upside potential lies in the products.

If the recycled fertilising products were mineral fertilisers, the market value of the nutrients in the recycled product would come close to 750,000 €, even if modestly calculated at € 500/t for each N, P and K. It is clear that recycled products typically cannot achieve similar sales prices as mineral fertilisers, albeit some examples for customers paying similar or even higher prices exist (e.g. Ostara Nutrient Recovery Inc. for struvite produced from sewage sludge or Magic Dirt potting soil in the US). Companies like Ostara invested heavily in creating a product brand (Crystal Green™) and started selling the product to niche markets. Even if Ostara typically operates in a more favourable environment, they too had to confront real barriers, for instance offering a product derived from sewage sludge. Even if location, quantities produced, risk averseness in Europe and legal framework may provide more constraints for AM-Power than Ostara had to face, the fact that examples of developing a market and demand for recycled products at high prices exist, indicates that looking for niche markets and adapting the product to the requirements of such markets will most likely be the best option for increasing the operational profit of the plant.

However, marketing, sales and application of the recycled materials as chemical product is subject to REACH application. It is expected, that the European Commission will exempt digestate from REACH registration similar to compost (to be published in Qu3/2019) but this exemption will most likely not apply to products derived from digestate.

Another opportunity for higher profits and a more resilient business case may be opened if the definition of "treated manure" in the Nitrates Directive were amended. However, it is still questionable if the NK-concentrate qualifies as pure mineral fertiliser, which could be exempted from the use restrictions under the Nitrate Directive.

In conclusion, the business case of AM-Power does not fly without nutrient recovery and recycling. On the contrary, the company faced substantial losses before having implemented the upgraded cascade NRR system due to the exorbitant expenses for disposing of the digestate. Like in every region with high livestock density, the key to profitable operations is reducing the quantity of effluents from the plant by solid/liquid separation and by production of N-P-K concentrates with higher nutrient concentrations that can be transported with lower specific costs. The nutrient depleted liquid fraction

must be purified to be dischargeable to the sewage system. AM-Power has implemented the most promising NRR system and can hope that the expected performance and corresponding financial results will be achieved.

## 10 Business Case Analysis

The business case of AM-Power is characterised by very high expenses for the feedstock (about 1,750 M€/y) and high expenses for disposal/application of the digestate. The former is determined by the high local competition for substrate having caused the loss of bargaining power to the food industries as main substrate suppliers and having turned an initial gate-fee into a price (currently about € 15/ton of biowaste). The substrate price will not change as long as demand exceeds supply.

In turn, digestate disposal/application costs which were extremely high before the new NRR cascade was implemented (over 2.9 M€/y) have now returned to manageable costs of about 1,25 M€. Apart from some savings on chemicals use and maintenance, NRR makes the difference between a modest profit and high losses. Within the prevailing economic and regulatory framework, NRR is key to turn around the business case of AM-Power.

Due to the current biogas support system in Belgium and the corresponding agreements of AM-Power, revenues from heat and power supply are satisfactory, in the order of 7 M€. The main contribution to the annual revenues stems from "green certificates" at a value of € 100/MWh, covering the whole electricity production and a reasonable bonus for heat use. However, the current legislative framework in Belgium does not leave room for alternative options, for instance upgrading biogas to biomethane. If SYSTEMIC can contribute to convincing political decision makers in Belgium to provide more options for biomass and biogas conversion, AM-Power would have more upside potential. The European Commission has done its homework and published the RED II Directive for a more harmonized European framework for renewable, biomass-based energy.

Among the SYSTEMIC demonstration plants, AM-Power managers have to navigate business in the most challenging environment. The high cost on both ends – feedstock and digestate – seems to be the main problem. NRR solves the problem at one end but cannot contribute anything to the feedstock end. Focusing on negotiations with suppliers and possibly looking for new supply sources could be a promising strategy.

Due to the constraints of using the products in Belgium, even the recycled products do not produce net revenues – because of elevated the transport cost. However, similar to the situation in The Netherlands the upside potential lies in the products.

If the recycled fertilising products were mineral fertilisers, the market value of the nutrients in the recycled product would come close to 750,000 €, even if modestly calculated at € 500/t for each N, P and K. It is clear that recycled products typically cannot achieve similar sales prices as mineral fertilisers, albeit some examples for customers paying similar or even higher prices exist (e.g. Ostara Nutrient Recovery Inc. for struvite produced from sewage sludge or Magic Dirt potting soil in the US). Companies like Ostara invested heavily in creating a product brand (Crystal Green™) and started selling the product to niche markets. Even if Ostara typically operates in a more favourable environment, they too had to confront real barriers, for instance offering a product derived from sewage sludge. Even if location, quantities produced, risk averseness in Europe and legal framework may provide more constraints for AM-Power than Ostara had to face, the fact that examples of developing a market and demand for recycled products at high prices exist, indicates that looking for niche markets and adapting the product to the requirements of such markets will most likely be the best option for increasing the operational profit of the plant.

However, marketing, sales and application of the recycled materials as chemical product is subject to REACH application. It is expected, that the European Commission will exempt digestate from REACH registration similar to compost (to be published in Qu3/2019) but this exemption will most likely not apply to products derived from digestate.

Another opportunity for higher profits and a more resilient business case may be opened if the definition of "treated manure" in the Nitrates Directive were amended. However, it is still questionable if the NK-concentrate qualifies as pure mineral fertiliser, which could be exempted from the use restrictions under the Nitrate Directive.



In conclusion, the business case of AM-Power does not fly without nutrient recovery and recycling. On the contrary, the company faced substantial losses before having implemented the upgraded cascade NRR system due to the exorbitant expenses for disposing of the digestate. Like in every region with high livestock density, the key to profitable operations is reducing the quantity of effluents from the plant by solid/liquid separation and by production of N-P-K concentrates with higher nutrient concentrations that can be transported with lower specific costs. The nutrient depleted liquid fraction must be purified to be dischargeable to the sewage system. AM-Power has implemented the most promising NRR system and can hope that the expected performance and corresponding financial results will be achieved.

# 13 Annex 3 Business Case Evaluation BENAS GmbH

# Business Case Evaluation

---

Gesellschaft für  
Nachhaltige  
Stoffnutzung mbH



## BENAS Biogas Plant GmbH

---





## Content

1	Executive Summary.....	III
2	Company Description.....	V
2.1	Promoters and Shareholders .....	V
2.2	Advisors .....	V
2.3	Products and Services .....	V
2.4	Continuous Business Development .....	VII
3	SWOT Analysis.....	VIII
4	Market Analysis.....	IX
4.1	Target Market.....	IX
5	Marketing/Sales Strategy.....	XI
6	Research and Development.....	XIII
6.1	Technology Roadmap .....	XIII
6.2	Research and Development.....	XIII
6.3	Technical Partners.....	XIII
6.4	IP, Patents, Copyrights, Brands .....	XIII
7	Staffing and Operations.....	XIV
8	Investment and Funding.....	XV
9	Financial Data.....	XVI
9.1	Business Case with NRR.....	XVI
9.2	Business Case without NRR .....	XVI
10	Business Case Analysis.....	XVIII

# 1 Executive Summary

This business case evaluation covers BENAS GmbH, a thermophilic anaerobic digestion (AD) plant in Ottersberg (40 km east of Bremen), Lower Saxony, Germany, in operation since 2006 with a total annual substrate processing capacity of 174,000 t. Processing corn silage, plant residues and poultry litter.

*Table 1.1 BENAS Plant characteristics*

Date of commissioning	2006
Annual substrate processing capacity / processed	174,000 t / 102,000 t (82 kt corn & plant residues / 20 kt poultry litter)
Installed electric capacity (IEC)	11.3 MW
Installed biomethane capacity	1,200 m <sup>3</sup> /h
Digester volume	26,000 m <sup>3</sup>
Annual biogas output / biogas per t of feedstock	20 Mm <sup>3</sup> / 194 m <sup>3</sup> /t
Annual electricity net-output (fed to the grid)	26,972 MWh (23,610 MWh <sub>el,tot</sub> + 25,580 MWh <sub>heat</sub> )
Annual bio-methane output	8,78 Mm <sup>3</sup> (1,200 m <sup>3</sup> /h)
Digester type	Thermophilic Continuous Stirred-Tank Reactor (CSTR)
Nutrient recovery & recycling (NRR) facilities	FibrePlus ammonium stripping system Screw press for solid/liquid separation Rotary drum dryer for digestate
NRR Products	Hygienised dewatered / dry digestate Ammonium sulphate (3,700 t/a) Calcium carbonate (1,000 t/a) Hygienised, dry digestate Fibres
Framework conditions relevant to the business case	Biogas storage capacity 39,000 m <sup>3</sup> Owners cultivate 3,500 ha agricultural land, 2,000 ha c. 200 km distant from biogas plant Double IEC for full flexibility Desulphurisation gypsum used for ammonium sulphate production FibrePlus system for future production of fibres

BENAS is the anaerobic digestion activity of the Heitmann family. It comprises two biogas plants in Lower Saxony, of which the newer and larger one in Ottersberg is subject to this study, and some 3,500 hectares of own and leased cropland, part of it close to the biogas plants and part of it some 200 km to the east.

The SYSTEMIC demonstration plant processes some 174,000 tons of substrate (energy crops, agricultural residues and chicken litter) and is equipped with state-of-the-art equipment for flexible energy conversion and nutrient recovery and recycling: up to 11.3 MW installed electrical power and gas purification for 1,200 m<sup>3</sup>/h bio-methane. Together with the total storage volume of 32,500 m<sup>3</sup> biogas, the plant can perfectly respond to grid fluctuations and – in future – to power price fluctuations. Power supplies to the grid are already controlled by the local utility cutting off power supply in case of peak grid loads.

BENAS operations are truly circular and served by its own vehicle fleet for transport, handling and spreading. Feedstock is collected from and separated nutrients are returned to own and leased agricultural land. N is stripped by GNS' modified stripping process using secondary gypsum (from power plant flue gas cleaning) as low-cost reaction partner for ammonium sulphate production. In average, 11 t/day of ammonium sulphate and 3 t/day of calcium carbonate fertilisers are produced. Apart from recycled fertilisers, the plant can recover fibres for cardboards and other, more innovative applications such as biodegradable pots for plants. The technology has been developed by GNS, a long-term partner and technical advisor to BENAS. The FiberPlus system is not yet working at full capacity – the market has still to be developed.

Research and investments are driven by the continuous pursuit of improvement and by preparing for the time when the German government may not subsidize biogas after the current contracts will have ended. The business case analysis shows that independence from subsidies can be achieved. BENAS has developed its biogas activity into a highly resilient business case with a profit rate exceeding 13% of sales and still having room for improvement, once the market for biodegradable fibres will have been developed.

## 2 Company Description

### 2.1 Promoters and Shareholders

BENAS, an agricultural SME, is the Heitmann family business. OPEX and smaller investments are financed by the cash-flow and larger CAPEX by loans from the house bank. Research funding was received to pilot the FiberPlus technology. Senior Jürgen Heitmann is responsible for farmland and crop cultivation, junior Christoph Heitmann for the biogas plant and digestate treatment.

### 2.2 Advisors

GNS has been working for BENAS since 2007. After GNS providing the engineering, the first modified stripping facility of GNS was built by BENAS without additional external service and construction companies. GNS is a small R & D and engineering company. The owners, Bauermeister, Meier and Spindler, know how to engineer, build and operate effective biogas facilities and peripheral nutrient recycling technologies. Ute Bauermeister is the managing director of GNS. GNS has two minority shareholders, an analyser manufacturer and a plant construction company with <25% of shares. GNS typically performs R & D projects with external (public) research funding, has invented the modified stripping process and developed it into the FiberPlus process in cooperation with BENAS.

### 2.3 Products and Services

The BENAS biogas plant, located near Bremen, was built in 2005/2006 with 5 MW power capacity that was extended by 6 MW in 2018. In 2012 an additional gas purification system was installed to convert biogas to 1,200 Nm<sup>3</sup>/h bio-methane for higher energy flexibility.

The thermophilic plant has 4 digesters and 3 covered storage tanks with a total volume of 39,000 m<sup>3</sup>. Its operational permit covers co-fermentation of animal waste, agricultural residues, crops and food waste with a capacity of 174,000 t/y.

BENAS grows energy and other crops on 3.500 ha owned and leased farmland with 35 employees. Part of the cropland is located up to 200 km from the biogas plant requiring transport of crops and digestate over long distances by an own truck fleet. In the early days more liquid substrates were used and about 180 t/d digestate was produced. Because of high transport costs and the limits for nitrogen application on cropland, BENAS looked for a technology to recover nitrogen and reduce the amount of digestate for field application. In 2007, the GNS System ammonia stripping plant was built.

The GNS System is a modified ammonia stripping process, by which ammonia and carbon dioxide are removed slightly below atmospheric pressure at temperatures of 50-85 °C without chemicals. By binding ammonia and carbon dioxide with gypsum (FGD-gypsum preferred) instead of sulfuric acid, CO<sub>2</sub> emissions are reduced. The mineral process outputs are concentrated ammonium sulphate solution (25%) and a solid calcium carbonate fertilizer. An integrated precipitation of phosphate and (partly) potassium is possible without using additional chemicals. The precipitation products are removed from the process during separation of the digested solids.

The utilization concept and mode of operation of the biogas and peripheral stripping plant have undergone multiple adjustments since 2008. In 2011, process flows of the stripping plant were optimized, which led to a notable reduction of operating expenses. The feedstock gradually changed to more solid and nitrogen rich animal waste like poultry litter. By recycling the ammonia reduced liquid digestate into the digester, ammonia-inhibition is avoided and the amount of digestate for field application is reduced to about 30 %.

Currently the biogas plant processes about 160 t/d corn silage, 70 t/d of other agricultural material and 50 t/d of chicken litter. The stripping plant is operated with a flow rate of 8-10 m<sup>3</sup>/h digestate without solid/liquid separation by a screw press. It consumes about 800-1,000 kWh/h of exhaust heat.

Chicken litter contributes up to 40 % of the nitrogen in the BENAS biogas plant. The stripping plant System GNS removes more than 30 % of the total nitrogen as NH<sub>4</sub>-N bound to mineral fertilizers. The remaining, mostly organic nitrogen is mainly concentrated in the nutrient-rich organic solid fertilizer from the separation process. The process flow is shown in figure 1.

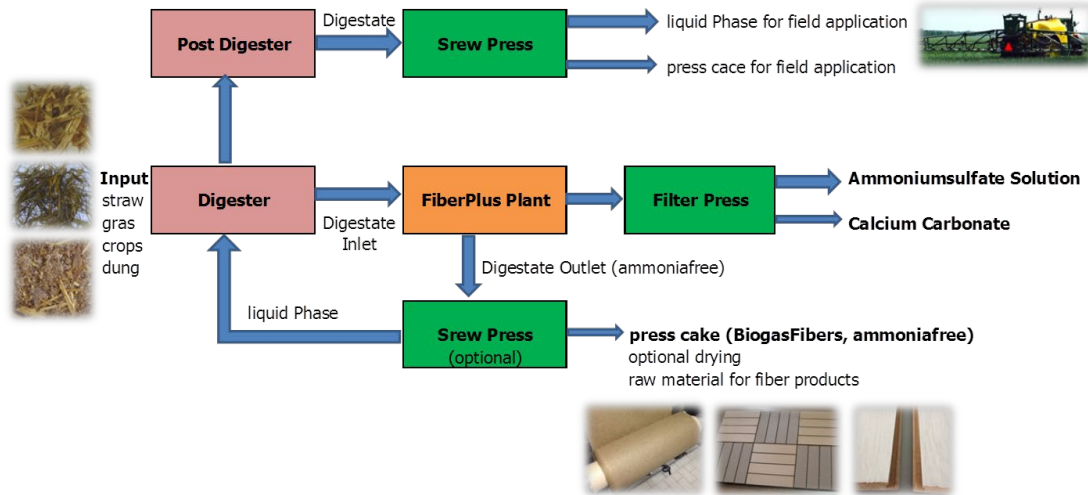

Figure 2.1: Process flows with N recovery at BENAS

The plant produces about 11 t/d ammonium sulphate fertilizer and 3 t/d calcium carbonate fertilizer (see Tab. 1). The mineral fertilizers as well as the separated solid substrates satisfy on-site requirements in the cultivation of corn silage and other crops grown by BENAS.

Table 2.1: Operating data of the BENAS stripping plant

Input		Output	
Inflow [m <sup>3</sup> /d]	192	Outflow [m <sup>3</sup> /d]	~ 182
NH <sub>4</sub> -N [g/l]	3.85 - 4.45	NH <sub>4</sub> -N [g/l]	0.7 - 0.85
DM [%]	7.1 - 11.5	DM [%]	8 - 12
pH	8.1 - 8.4	pH	8.9 - 9.6
Conductivity [mS/cm]	20 - 22	Conductivity [mS/cm]	10 - 13
FGD-gypsum [t/d]	4 - 5	Calcium carbonate fertilizer, t/d, (76 % DM, 37 % CaO, 2 % N and 3 % S)	2.9 - 3.4
		Ammonium sulphate solution, t/d, (5 % N, 6 % S)	10.5 - 13

Since 2012, the FiberPlus-Technology System GNS has been developed and gradually implemented. In an on-site pilot facility (figure 2) unseparated digestate is treated to remove ammonia. After solid/liquid separation by a screw press, ammonia free lignocellulosic fibres are produced and tested as wood substitute in wood-based materials for interior room applications on an industrial scale. Up to 30 % biogas fibres in particle board, MDF and HDF boards are possible (figure 3).



Figure 2.2: Pilot Plant FiberPlus



Figure 2.3: Biogas fibres in particle boards & MDF

## 2.4 Continuous Business Development

BENAS has developed a profitable “Circular Economy” business model by mixing home-grown energy crops with bio-waste / manure and recycling digestate borne nutrients to own cropland with 100% credit for the nutrient value (digestate borne nutrients can fully replace mineral fertilisers). However, the favourable power feed-in tariff is still significantly contributing to the business results.

Consequently, the company will continue its transition from an energy conversion facility to a bio-refinery and pursuing to yield the maximum value from energy-, nutrient- and biomass flows.

- a) Energy, by maximising the benefits of storable biogas (bio-methane) in a highly fluctuating renewable energy supply world
- b) Nutrients, by separating N and P to produce concentrated, transportable fertilising products that can be blended to the requirements of crops
- c) Biomass, by producing cellulosic fibres, from about 1/3 of the dry matter plant input and recycling them in cooperation with companies that close the loop to the market.

In the long run, BENAS aims at being prepared for operating the plant without guaranteed feed-in tariffs, mainly by stabilizing the grid-load during periods of high fluctuation or insufficient supply of other renewable energy sources. For this purpose, BENAS invested in large biogas storage capacities.

In addition, resource recovery will become more important for long-term benefits, both for sustainability and profits. What was a simple biogas plant in the past will become a full-scale biorefinery in the future.

Short-term goals pursued during the project:

- a) Further integration of the FiberPlus technology and continuous production of cellulosic fibres as substitute for wood in panels
- b) Separation of a phosphorus enriched solid fraction is pursued and may be installed in the course of the SYSTEMIC project if technically feasible and economically viable.

### 3 SWOT Analysis

<p><b>Strengths</b></p> <ul style="list-style-type: none"> <li>• High percentage of substrate produced on own farmland</li> <li>• All products can be used on own farmland</li> <li>• High flexibility in energy conversion, preparedness for regulatory changes</li> <li>• Robust, proven NRR technology</li> <li>• Only recycled chemicals needed</li> <li>• Low OPEX</li> <li>• Fibre rich digestate can be recycled to             <ul style="list-style-type: none"> <li>○ Ammonium sulphate solutions (ASL)</li> <li>○ Lime</li> <li>○ Cellulosic fibres suitable for replacement of wooden biomass</li> </ul> </li> </ul>	<p><b>Weaknesses</b></p> <ul style="list-style-type: none"> <li>• No treatment of liquid digestate to dischargeable water</li> <li>• Potentially higher CAPEX (filter press, 3-4 stripping vessels)</li> <li>• Dependency on energy crops</li> </ul>
<p><b>Opportunities</b></p> <ul style="list-style-type: none"> <li>• Fibre production for sustainable fibre products with high value in Future</li> <li>• Higher substitution of energy crops by organic waste products</li> </ul>	<p><b>Threats</b></p> <ul style="list-style-type: none"> <li>• Unforeseeable regulatory changes</li> <li>• Fluctuation of energy prices</li> </ul>

# 4 Market Analysis

## 4.1 Target Market

### Market Segments:

- Electricity = good prospects, with two new CHPs with a total of 6 MW<sub>el</sub> capacity BENAS can nicely adapt its power production to market fluctuations
- Bio-methane as alternative to electricity with higher conversion efficiency and possibly higher revenues if feed-in tariffs are not provided in future scenarios
- Mineral fertilisers (ammonium sulphate, calcium carbonate) = nutrient value fully accountable due to saving purchased fertilisers
- Biogas Fibres = expected growing acceptance

### Market Trends

Without unforeseeable major political disruptions, Germany is expected to continue its pathway towards reducing greenhouse gas emissions and replacing fossil by renewable energy carriers. Large biogas plants like BENAS can be a stabilising factor in power grids in the future with highly fluctuating energy sources: biogas is continuously produced and storable. It does not look like biogas not being part of a future fuel mix – it could even play a more important role, e.g. biomethane-based CNG or LNG as transport fuel for long haul traffic as currently pursued in the Nordic countries.

In a Circular Economy, plants that recycle all of their input flows with potential for up-cycling (cellulosic fibres from fibrous input materials) should be very well positioned. If BENAS succeeds to sell fibres close to their real market value, the FiberPlus facility can become a third pillar of solid revenues next to energy and nutrients.

### Profile of Competitors

- Typically, no or not enough cropland for fully circular fertiliser use
- Need to sell fertilising products far below nutrient market value
- No energy product flexibility (power / bio-methane)
- Limited (energy) storage capacity
- Classical ammonia stripping: only with fine separated liquid (no fibres in it), ammonia is captured with sulphuric acid = higher operating costs
- Evaporation: only with fine separated liquid (no fibres in it), ammonia is captured with sulphuric acid, more heat is used = higher operating costs

### Competitive Advantage of the FiberPlus System

The FiberPlus technology is a stripping technology, not a total digestate treatment. This has to be combined with other technologies (P-recovery, drying, membrane technology). The main advantages are:

- Zero chemical and low energy consumption (electricity, heat) = low operating costs
- treatment of digestate before separation reduces the costs of the combined technology (total treatment) and leads to an additional value material (fibres)

The FiberPlus technology is competitive for digestate treatment > 5 m<sup>3</sup>/h. The total operating costs are between 5 €/m<sup>3</sup> (only stripping and separation) to 16 €/m<sup>3</sup> (combined with total treatment solutions to dischargeable water).

### FiberPlus Benefits to Clients

BENAS and other potential users can have the following benefits from GNS's FiberPlus System:



- Full integration of ammonia stripping, ammonia recycling and production of two fertilising materials (ammonium sulphate and calcium carbonate) and cellulosic fibres
- Recycling of low ammonia digestate within the digester plant avoiding nitrogen inhibition of biogas conversion
- Ammonia stripping cycle being less sensitive to fibres than conventional stripping technologies
- Technology is an appropriate first step towards treating the liquid effluents to dischargeable water

# 5 Marketing/Sales Strategy

Since no fertilising products are sold by BENAS (all recovered nutrients are used on the company's own cropland) marketing and sales are focused on fibres and on the FiberPlus technology. In addition, the product and technology roll-out is mainly performed by GNS.

Position of the FiberPlus technology and service in the market:

- Which segments of the market have been/will be targeted first and why?
  - Biogas plants with fibre rich input, biogas plants for poultry litter, part of total treatment, treatment of  $> 5 \text{ m}^3/\text{h}$
- How will this be developed to reach the full target market?
  - Step by step with partners whereby BENAS is the pilot installation
- How will the product be differentiated from other products or services?
  - By the above-mentioned competitive advantages
  - By offering a complete expert package including consulting, project development, engineering and advice during construction and commissioning
- What key benefits will be highlighted?
  - Zero chemicals and low energy consumption (electricity, heat) make the process highly competitive
  - Treatment of digestate before separation reduces the costs of the combined technology (total treatment) and leads to an additional value material (fibres)
- What potential customers have been already targeted?
  - Biogas plants with fibre rich input, biogas plants for poultry manure, part of total treatment, treatment of  $> 5 \text{ m}^3/\text{h}$
- Is there a test site in operation, and what feedback is coming from this?
  - BENAS is the first-of-its-kind installation
- What contacts can be used to generate market awareness and sales?
- Who does/will do the marketing: staff, agency, reps?
  - BENAS and GNS work in a partner consortium

## Revenues related to NRR

BENAS currently does not have direct revenues from recycled nutrients or fibres. However, nutrient recycling generates highly relevant indirect revenues.

*Table 5.1 Sources of revenues*

	<b>Home country</b>	<b>EU (neighbouring) countries</b>
Fertiliser replacement	276.000,00	n.a.
Fibres (only sample sales)	1.000,00	n.a.
Substrate mix	322.000,00	n.a.
Energy conversion, lower yield	635.000,00	n.a.
Total revenue from NRR	1,234.000,00	n.a.
Additional costs from NRR	521.000,00	n.a.
Net operating benefit from NRR	713.000,00	n.a.

### **Sales Strategy**

BENAS draws sales and profits from the further optimization of the FiberPlus plant and can in future support the construction of new plants with its know-how. Technology improvements will be first installed and tested at BENAS.

GNS is a know-how owner for design and engineering and offers support / monitoring for future plants. Sales is / will be organized in a partner consortium.

### **Pricing**

- Perception of quality-price relationship by customers
- Production costs and overheads
- Chain of distribution and the added-value at each stage
- The extent to which the buyer can control the price

### **Marketing and Communications Strategy**

- Public relations
- Direct marketing
- Website and internet marketing
- Exhibitions and conferences
- Word of mouth

# 6 Research and Development

## 6.1 Technology Roadmap

The roadmap for BENAS is characterised by further increasing its flexibility with regard to feedstock (increasing waste substrates in exchange for energy crops), power supply (increasing storage capacities for using high tariff periods instead of continuous supply) and value products from digestate (market roll-out for the fibres).

## 6.2 Research and Development

GNS has and will have ongoing R&D as an activity of the company:

- Development in Biogas-Fibre-Separation, quality and application
- Development of higher value fertilizer products
- Development of other applications of the FiberPlus-technology for NNR

## 6.3 Technical Partners

The cooperation between BENAS and GNS will continue whereby BENAS will continue as first user of GNS developments. Other partners are not in the focus at present.

## 6.4 IP, Patents, Copyrights, Brands

GNS holds the patent for the modified stripping process. The IP is not only protected by the patent. More important may be the know-how of how to implement and operate the process.

In addition, developing the FiberPlus brand and promoting the advantages of the process are the next steps of the market roll-out.

# 7 Staffing and Operations

## Management (including Board) Organisation Chart

The company is managed by Jürgen Heitmann (focus on agricultural activities) and Christoph Heitmann (focus on energy activities).

## Staffing

BENAS counts on a team of about 20 employees for operating the two biogas plants and the agricultural activities.

## Training Plans

BENAS employees are trained by the managers (J. and C. Heitmann) and by GNS. Special training sessions are organised during and after the installation of new equipment and the inclusion of new activities.

GNS trains process engineers at Merseburg University of Applied Sciences and supervises ongoing student qualification work. In addition, qualified personal must be provided for several service and marketing.

## Operations

### Operations cover

- 2 Biogas plants in Vorwerk and Otterberg
  - Vorwerk: 2 digesters of 5.000 m<sup>3</sup> each and 2.200 kW electric power
  - Ottersberg: Reception and production hall of 30m x 50m equipped for energy crops and liquid substrates, air suction and gas sensors, centralised suction-pressure station for liquid substrates, moving floor for energy crops
  - 2 fermenters with 33m diameter, height 5,80 m, 2 post digesters and 2 final storage tanks, all same size and an additional new storage tank
  - Gas piping with centralised pressure and cooling station
  - Ammonium stripper, 25 m<sup>3</sup>/h (modified stripping system GNS)
  - Dewatering unit by screw press, 25 m<sup>3</sup>/h
  - Drum dryer for digestate drying to 90% DM, capacity 2.500 kg/h water evaporation
  - Drying hall, 30 x 18 m and 2.000 m<sup>3</sup> volume
  - Storage hall 50 x 25 m
- Collection of substrates and distribution of digestate and products by
  - 9 tractor-trailers
  - 4 stainless steel pump-tankers
  - 7 trailers with different functions
  - 5 wheel-loaders
  - 14 tractors
  - 2 combined harvesters
  - 10 transporters for liquid and solid goods

## Suppliers

Poultry farms and other suppliers of organic waste in the neighbourhood of the plants.

## 8 Investment and Funding

The biogas plant as demonstrated today is the result of a sequence of investments and improvements that cannot be accounted to one single act of investment. In its current configuration, it represents an approximate CAPEX value of 20 M€.

BENAS funded its innovation activities from the company cashflow and with credits from its house bank. The company does not need funding support from public sources.

# 9 Financial Data

## 9.1 Business Case with NRR

### Profit & Loss summary (2018)

Table 9.1 P & L summary in EUR

<b>BENAS</b>	<b>Revenues</b>	<b>Expenses</b>	<b>Balance</b>
Substrates (feedstock)		3.016.626	-3.016.626
Energy and Green Certificates	7.920.373	398.400	7.521.973
Product sales / savings	277.160		277.160
Consumables (chemicals, spare parts)		17.604	-17.604
Digestate & NRR product handling (storage, application)		374.430	-374.430
Operations (personnel, overhead, maintenance, repair)		1.450.000	-1.450.000
Amortisation (12 years)		1.850.000	-1.850.000
	8.197.533	7.107.060	1.090.473
<b>EBITA (Earnings before interest, amortisation and tax)</b>		<b>2.940.473</b>	<b>EBITA Margin 36%</b>
<b>EBIT (Earnings before interest and tax)</b>		<b>1.090.473</b>	<b>EBIT Margin 13%</b>

## 9.2 Business Case without NRR

BENAS was an early adopter of nutrient recovery and recycling, starting as early as 2005 with the second digester plant of the company in Ottersberg.

NRR is motivated by two elements: i) the flexibility in selecting different input substrates, for instance replacing energy crops by poultry litter and other organic waste materials ii) the continuous endeavour for improvement in terms of technology, performance and financial results.

Without NRR, BENAS could not replace energy crops by poultry litter (about 20.000 t/year) and would consequentially have to accept a significantly higher cost of substrates and a slightly lower energy yield. In addition, the feed-in tariff would be lower by 20 EUR/MWh due to the missing use of heat that is positively accounted for in the German feed-in tariff scheme. The corresponding savings of CAPEX and OPEX do not compensate the income losses. More than 713.000 EUR of annual earnings would be sacrificed without nutrient recovery as shown in the table below.

Table 9.2 Financial results with and without NRR in EUR

<b>BENAS</b>	With NRR in €	Without NRR in €	Difference in €
Electricity output	4.855.000	4.220.000	635.000
Cost of substrates	-3.017.000	-3.339.000	322.000
Fertiliser replacement	277.000	0	277.000
CAPEX		-521.000	-521.000
EBIT (Earnings before interest and tax)	1.090.473	360.000	713.000



# 10 Business Case Analysis

The BENAS demonstration plant is a good example for a Circular Economy approach. Currently, all by-products are used to grow the crops fed into the plant and all consumables except fuels for transport are waste products. The minor flaws are land use for energy crop production and the transport distance between the cropland and the biogas plant. The corresponding environmental impact will be shown in the LCA to be performed as task 3 of WP2. Following the modifications of German legislation, the use of energy crops is gradually replaced by organic waste and chicken litter.

The BENAS business case is characterized by high substrate costs and high revenues from energy supplies (power and biogas) due to the high tariffs for feeding-in electricity (180 €/MWh) including the bonuses for heat use and flexibility, transferring the control of taking the plant from the electricity grid in case of periodical overload to the local utility.

Biogas which is upgraded to biomethane by the local utility (owning and operating the gas purification plant) almost offsets the substrate cost, both in the order of 3 M€. Electricity contributes almost 5 M€ to the annual revenues. BENAS is prepared for lower feed-in tariffs that may be expected after the expiry of the current contracts: i) the company has invested in large (39,000 m<sup>3</sup>) biogas storage facilities and almost doubled its installed power generation capacity enabling operators to concentrate electricity supplies to periods with high demand and corresponding high electricity prices; ii) the (non-subsidised) revenues from biogas are not much below the revenues from electricity, hence gradually switching energy conversion from power to biomethane does not significantly hamper the business case. However, electricity cannot be fully replaced by biomethane due to the need of heat for NRR which is provided by the highly efficient (>40% conversion efficiency) gas engines.

The direct contribution of NRR is due to savings of mineral fertilisers for growing the energy crops, representing about two thirds of the total feedstock, in the order of 280,000 €. However, indirect savings of NRR by additional power output and savings for processing poultry litter instead of energy crops amount to 950,000 €. Taking the additional CAPEX payback (10 years amortisation) of 521,000 € per year into consideration, net annual savings amount to 713,000 €.

Comparing the current business case with NRR, generating earnings before tax (EBIT) of 1,090,000 € and a satisfying EBIT margin of 13% to a business case without NRR, the EBIT margin would drop to 4%. The current resilience of the business case would be sacrificed, and the positive EBIT margin would be at risk in case of minor cost increases for the substrates.

The most recent recycling development, production of biodegradable, lignocellulosic fibres from digestate, has a high potential for improving the business case. BENAS has proved the concept by supplying fibres for the production of fibreboards but the output of BENAS does not meet the quantitative requirements of fibreboard producers – production is too small for being approved as a regular supplier. More promising are the newest developments like producing biodegradable pots for plants (avoiding the need to remove pots before planting the plants, e.g. in the garden) and producing special papers from the fibres. These products have the potential to improve the business case significantly but require additional marketing efforts and entail higher dependency on third parties.

An – at least theoretical – environmental improvement of the plant could be achieved by replacing the fossil fuel used for transporting raw materials and products by bio-LNG (liquid biomethane) or bio-CNG (compressed biomethane). This would require additional on-site investments to biogas liquefaction or compression. If this would be undertaken, all input materials to any of the plant's flows would be renewable and land use would be the only remaining issue. The corresponding benefits and impacts need to be discussed in the LCA report.

In conclusion – BENAS represents a resilient, closed loop business case that partly owes its highly attractive EBIT margin to the current feed-in tariff and bonuses. However, the deeper analysis shows that even under a less favourable legal framework, BENAS would convert biomass to bioenergy and generate revenues for its owners. A certain supplement for biomass-based, fully flexible energy supplies compared to volatile sun- or wind-based power should of course always be provided by policy makers, but this is anyway foreseen in the different strategic options investigated by the European Commission in the EU-2050 low or net zero carbon scenarios.

## 14 Annex 4 Business Case Evaluation Groot Zevert Vergisting B.V.

# Business Case Evaluation

---



## Groot Zevert Vergisting

---



## **CONTENT**

<b>1</b>	<b>Executive Summary</b>	<b>III</b>
<b>2</b>	<b>Company Description</b>	<b>IV</b>
2.1	Promoters and Shareholders .....	IV
2.2	Advisors .....	IV
2.3	Products and Services .....	IV
2.4	Long Term Aim of the Business.....	V
2.5	Objectives.....	V
<b>3</b>	<b>SWOT Analysis</b>	<b>VI</b>
<b>4</b>	<b>Market Analysis</b>	<b>VII</b>
4.1	Target Market.....	VII
4.2	Market Trends .....	VII
4.3	Profile of Competitors.....	VII
4.4	Competitive Advantage.....	VII
<b>5</b>	<b>Marketing/Sales Strategy</b>	<b>VIII</b>
5.1	Marketing Strategy .....	VIII
5.2	NRR Revenue Sources .....	VIII
5.3	Sales Strategy .....	VIII
5.4	Pricing .....	VIII
5.5	Communications Strategy .....	IX
<b>6</b>	<b>Research and Development</b>	<b>X</b>
6.1	Technology Roadmap .....	X
6.2	Ongoing Research & Development .....	X
6.3	Technical Partners.....	X
6.4	IP, Patents, Copyrights, Brands .....	X
<b>7</b>	<b>Staffing and Operations</b>	<b>XI</b>
7.1	Management (including Board) Organisation Chart.....	XI
7.2	Staffing .....	XI
7.3	Training Plans.....	XI
7.4	Operations .....	XI
<b>8</b>	<b>Investment and Funding</b>	<b>XII</b>
<b>9</b>	<b>Financial Data/Projections</b>	<b>XIII</b>
9.1	Profit & Loss Summary (2018 Result/2019 Projection).....	XIII
9.2	Business Case without NRR .....	XIII
<b>10</b>	<b>Business Case Analysis</b>	<b>XV</b>

# 1 Executive Summary

This business case evaluation covers Groot Zevert Vergisting, a mesophilic anaerobic digester (AD) plant in Beltrum (35 km southwest of Enschede), Achterhoek Region, Province Gelderland, in operation since 2004 with a total annual substrate treatment capacity of 135.000 t. Processing manure and biowaste.

*Table 1.1 Groot Zevert Vergisting Plant characteristics*

Date of commissioning	2004
Annual substrate processing capacity / processed	135,000 t / 120,000 t (90 kt manure / 30 kt biowaste)
Installed electric capacity (IEC)	6.5 MW
Installed biomethane capacity	None, biogas is directly sold to FrieslandCampina
Digester volume	15,000 m <sup>3</sup>
Annual biogas output / biogas per t of feedstock	10 Mm <sup>3</sup> / 75 m <sup>3</sup> /t
Annual electricity net-output (fed to the grid)	3,200 MWh (5,000 MWh <sub>el,tot</sub> )
Annual biogas output	6,5 Mm <sup>3</sup>
Digester type	Thermophilic Continuous Stirred-Tank Reactor (CSTR)
Nutrient recovery & recycling (NRR) facilities	GENIAAL – flotation, microfiltration, reverse osmosis RePeat – acidification and struvite reactors
NRR Products	Mineral NK concentrate Struvite, P-depleted organic product
Framework conditions relevant to the business case	High livestock density in the region Products need to be transported to other regions or treated

Groot Zevert Vergisting (GZV) is part of a family business in Beltrum, Province Gelderland, The Netherlands. The company converts each year some 135,000 tons manure (80%) and organic waste (20%) to about 10 Mm<sup>3</sup> biogas. 80% of the biogas is sold to a nearby dairy plant of FrieslandCampina via pipeline and 20% is converted to electricity, used for plant operations and fed-in to the power grid.

GZV started operations in 2004 and has continuously expanded activities, until 2018 mainly by capacity expansions. Due to increasing regulatory pressure related to disposing and applying the digestate in the Netherlands and – more recently – also in Germany, to where a relevant fraction of the digestate has been exported, GZV’s management started screening the various options of nutrient recovery and recycling (NRR). Due to the high cost of digestate management, about 2.4 M€ per year, the potential for technical treatment and production of fertilising products with higher nutrient concentration (and consequently lower transport and application cost) was obvious.

In cooperation with Wageningen Research and Nijhuis Industries GZV developed and implemented a comprehensive NRR system based on an initial solid/liquid separation and a process chain for converting the liquid fraction into a N-K concentrate and dischargeable water and the solid fraction into struvite and a P-depleted organic fertilising product. The system is now in full operation and delivers the expected results.

After having installed the NRR system, GZV has improved its earnings before interest and tax (EBIT) by more than 200%. The business case became much more resilient to a changing regulatory, economic and environmental framework.

## 2 Company Description

### 2.1 Promoters and Shareholders

Groot Zevert Digestion Ltd. is located at the Deventer Kunstweg 2a in Beltrum (region Achterhoek of the Province Gelderland, The Netherlands)<sup>1</sup>. Groot Zevert Digestion Ltd is a subsidiary (daughter company) company of Groot Zevert Loon- en Grondverzetbedrijf. It is a family business dealing with agricultural services and road construction. At this moment 40 full time equivalent (FTE) are working at Groot Zevert of which 10 FTE are working on the biogas plant or responsible manure and digestate transport. In 2004 the first biogas production activities started (digestion of manure). In the following years, Groot Zevert Digestion Ltd extended and is now one of the largest AD plants (manure and co-digestion materials) in the Netherlands. Groot Zevert Digestion Ltd is a front runner in the application of manure processing techniques in The Netherlands.

### 2.2 Advisors

**Technical advisors: Nijhuis Industries**

**Scientific advisor: Wageningen Research**

### 2.3 Products and Services

#### **Background to its development**

Background: In 2004, GZV started with a relatively small AD plant. In the following years, the digestate treatment capacity was expanded several times and nowadays the plant has a capacity of over 100,000 tons of feedstock per year.

#### **Benefits and Features**

Feedstock is mainly pig manure (80%) and 20% co-digestion products (unborn manure, glycerine, biowaste from food processing industry).

**Manure treatment:** GZV offers a sustainable and affordable solution for pig farmers who cannot use their manure on their own land. A beneficial aspect is that GZV has its own trucks and truck drivers which allows them to pick up manure from the farm as a service to the farmer. Furthermore, they take care of handling, application and disposal of the produced digestate or the solid and liquid fraction of the digestate.

Until 2018, digestate was exported to Germany due to the excess amount of manure (mainly phosphorus) in The Netherlands. From 2019 onwards, GZV will process manure into various bio-based fertilisers that can be used within the region. Digestate will be separated into a solid and a liquid fraction. The GENIAAL installation will use the liquid fraction for further processing into NK-concentrate and clean water. The clean water is allowed to be discharged directly to the surface water (Brook Berkel). The RePeat installation will process the solid digestate fraction into more crystalline, magnesium-based precipitates (mainly as struvite) or more amorphous calcium-based phosphate (mono and dicalcium phosphate) and a phosphorus-poor organic fraction which can be used as soil conditioner on arable land or as substitute for peat material in potting soils.

---

<sup>1</sup><https://www.google.nl/maps/place/52%C2%B005'25.7%22N+6%C2%B034'15.0%22E/@52.0905723,6.569506,703m/data=!3m1!1e3!4m13!1m6!3m5!1s0x0:0x6af09614c899c5f8!2sGroot+Zevert+Vergisting+B.V.!8m2!3d52.088988914d6.581295513m5!1s0x0:0x017e2!8m2!3d52.0904774!4d6.570828>

### **Unique Selling Points**

GZV is a partner in the 'Bio-based Fertilisers Achterhoek' (<https://kunstmestvrijeachterhoek.nl/reason-and-purpose/?lang=en>) pilot project. This allows them to blend mainly recovered N-products (NK concentrates, ammonium sulphate and ammonia water) to be used on grassland as alternative for synthetic fertiliser during a four-year exemption period. The exemption is regulated in the "6<sup>th</sup> Action Plan Nitrate Directive" in the Netherlands in a formal agreement with the EC Nitrate Committee.

The RePeat installation is the first full-scale installation for the recovery of phosphate from digestate into a mineral based P fertiliser and a phosphorus-poor organic matter.

### **Advantages to Customers**

- Investment in nutrient recovery and reuse offers pig farmers a sustainable and affordable solution for the disposal for their manure.
- The NK concentrates offer an at least equal or cheaper source of mineral N for farmers as compared to synthetic N fertiliser. The nutrient ratio (N-K+S) will be adjusted to the customers' crops need through blending.
- The P-poor organic matter is characterized by very high organic carbon to P<sub>2</sub>O<sub>5</sub> ratio and is therefore a valuable soil improver. It enables farmers to apply a high amount of organic matter while keeping their phosphate application rate below the standards (60 kg P<sub>2</sub>O<sub>5</sub>/ha for arable land with a neutral P status). This organic matter material can probably also be used as substitute for peat in potting soils, a potentially promising market.

### **Disadvantages or Weak Points**

The long-term business case depends on end-of-manure criteria for the recovered N-based fertilisers from manure or manure based digestate. Those N-based mineral fertilisers will be extra valuable if they can be applied above the 170 kg N limit in nitrate vulnerable zones (or 230/250 kg on grassland on farms with derogation).

### **Future Developments**

Market development for bio-based fertilisers and derived products and optimizing the products in accordance with the needs of farmers or other purchasers.

## **2.4 Long Term Aim of the Business**

Turn manure into biogas, clean water and bio-based fertilisers and thereby offering a sustainable and affordable solution for the excess amount of manure in the region.

## **2.5 Objectives**

### **Milestones:**

- Investment in and commissioning of the 'GENIAAL' installation to produce NK concentrates (February 2019)
- Investment in and commissioning of the 'RePeat' installation to produce NK concentrates (expected: May 2019)
- Pilot Fertiliser-free Achterhoek: The national government granted a four-year exemption for the regional pilot in the sixth Nitrate Action Programme. That makes it possible to use NK concentrates instead of mineral fertiliser. (<https://kunstmestvrijeachterhoek.nl/reason-and-purpose/?lang=en>)
- Market development of bio-based fertilisers: 2019-2020

### 3 SWOT Analysis

<p><b>Strengths</b></p> <ul style="list-style-type: none"> <li>• Revenues/no cost from substrate</li> <li>• Contracted sales of biogas to nearby customer</li> <li>• All products can be used within the nearby region.</li> <li>• 70% of the water in digestate can be discharged to surface water.</li> <li>• Comparatively simple process design</li> <li>• No use of polymers or flocculants.</li> </ul>	<p><b>Weaknesses</b></p> <ul style="list-style-type: none"> <li>• Comparatively high investments in nutrient recovery installations.</li> <li>• First of its kind NRR-installation</li> <li>• The quality and stability of the product is not yet well defined including the fate of sulphate.</li> <li>• Agronomic parameters (Nitrogen uptake efficiency) of produced N-based fertilisers are not yet determined</li> </ul>
<p><b>Opportunities</b></p> <ul style="list-style-type: none"> <li>• Use of (blends of) NK concentrates as an alternative for synthetic fertiliser.</li> <li>• Use of organic matter (fibres) as an alternative for peat in potting soil or as soil improver on arable land.</li> <li>• Use of recovered mineral (Mg~P or Ca~P) as a secondary resource for the P fertiliser industry.</li> <li>• Emerging awareness in EC around manure status could open the possibility for applying mineral recovered nutrient end products &gt;170kg N/ha/year in nitrate vulnerable zones as "mineral fertiliser".</li> </ul>	<p><b>Threats</b></p> <ul style="list-style-type: none"> <li>• Risks associated with implementing new and innovative technologies</li> <li>• Fertilisers regulation: can the P fertilizer industry use the recovered mineral P as source to produce P-fertilisers.</li> <li>• Dependency on local dairy producer</li> <li>• Unforeseeable regulatory changes</li> </ul>



# 4 Market Analysis

## 4.1 Target Market

- The blend of NK concentrate is to be sold as an alternative for synthetic fertiliser and will dominantly be used on grassland. The market demand for bio-based N fertiliser is expected to grow in the coming years due to increasing knowledge on product quality and promotional activities but depends on whether the product will get an 'end-of-manure' status.
- The phosphorus-poor organic matter is to be sold as a soil improver on arable soils. There is a growing demand for organic soil improvers with a very low nutrient content because organic matter input is limited by N and P application standards. Customers prefer a product with a high humification coefficient, which means that after one year still a high amount of the applied organic matter is available. Moreover, the sulphur content of the organic matter should not exceed sulphur uptake rate by crops.
- Struvite is to be sold as an ingredient for the production of granulated organic or mineral fertilisers. Outside of The Netherlands, struvite is expected to have a market. It is in compliance with the requirement of a concentrated and nearly dry product which can be easily transported over long distances at low costs.

## 4.2 Market Trends

Within the framework of pursuing higher nutrient use efficiency, so-called bio-stimulants are expected to have the highest growth potential of all fertilising products. Bio-stimulants are typically used in small quantities. They aim at supporting the root development, nutrient uptake and crop resilience. The bio-stimulant market is addressed with the nutrient depleted, solid organic fraction of digestate.

The transition towards a Circular Economy will equally support the market roll-out of products produced by GZV.

## 4.3 Profile of Competitors

- Before the implementation of nutrient recovery and reuse, digestate competed with manure for crop- or grassland where it could be applied. Due to excess amount of manure in the region, digestate had to be transported to Germany.
- (Blends of) NK concentrates: There are no competitors within a radius of 30 km around the plant which is the area in which GZV aims to sell NK concentrates.
- P-poor organic matter: This product may compete with compost from green waste and VFG waste.
- For recovered mineral P there are no competitors yet in the region.

## 4.4 Competitive Advantage

- Ability to blend NK concentrates with other liquid N fertilisers producing a liquid fertiliser that meets crop demand in terms of N-K+S ratio and meets product criteria as laid down in the pilot 'Bio-based fertilisers Achterhoek'
- Organic matter with a very low nutrient content, especially P.

# 5 Marketing/Sales Strategy

## 5.1 Marketing Strategy

### **NK Concentrates:**

- Take part in the pilot project 'Bio-based fertilisers Achterhoek'.

### **P-Poor Organic Matter:**

- Perform research and field trials to demonstrate and prove product quality as soil improver including humification coefficient.
- Communicate the trial outcomes to farmer organisations. Expected benefits are the high organic matter to phosphate ratio.
- Perform tests to assess the quality of the organic matter in terms of potting soil ingredient and contact potential customers from the potting soil industry.
- Key benefit for potting soil producers will be the lower price as compared to peat.
- Key sustainability benefit will be the reduced peat extraction rates.

### **Recovered Mineral P Precipitate:**

- Determination of the value for P fertiliser (mineral/organic) industries or intermediaries

## 5.2 NRR Revenue Sources

	Home country	EU (neighbouring) countries
Products	Nutrient depleted organic matter N-K+S mineral concentrate	Potential for peat replacement as potting soil
Services	Manure handling services for the regional farming industry	
Licences	License for potting soil production (?)	License for potting soil production (?)
After sales	Digestate application (injection) Advise to farmers	
Upgrades	n.a.	

## 5.3 Sales Strategy

- Mostly through retail outlets or distributor
- Partly directly to customer

## 5.4 Pricing

- Gate fees for manure and co-digestion products depend on the level of competition in the market
- Price for N-K concentrates depends among others on the chain of distribution and the added-value at each stage. Costs for storage and logistics are high compared to synthetic fertiliser. Also, new machinery had to be developed in order to inject the liquid

N-K fertiliser to grassland. Manure injection is required in The Netherlands in order to reduce ammonia emissions but current machinery for manure slurry was not suitable due to the much lower product dosages of N-K concentrate as compared to slurry manure and digestate (Figure 1).

- Price of P-precipitates (struvite, Ca-P) and organic matter is likely to depend on the perception of quality-price relationship by customers

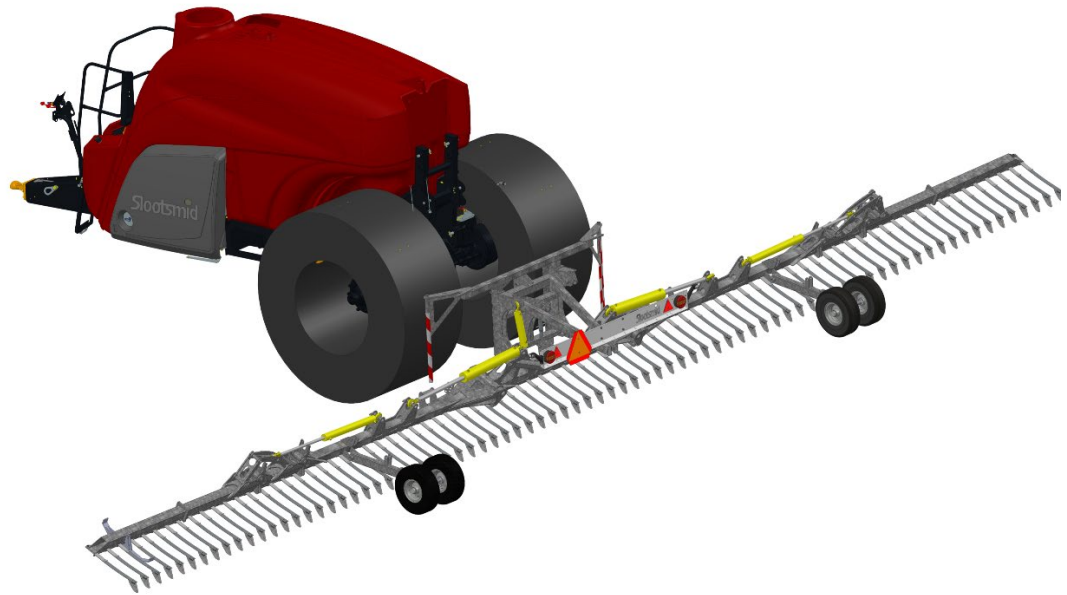

*Figure 1. Illustration of the new fertiliser injector developed to enable precise and low-emission fertilisation with bio-based N fertilizers.*

## 5.5 Communications Strategy

- Advertising in regional newspapers and farmer magazines
- Public relations, including PR provided by participation in the SYSTEMIC Project.
- Word of mouth

# 6 Research and Development

## 6.1 Technology Roadmap

The nutrient recovery installation implemented at GZV is the result of several years of R&D. Research questions to be addressed in the future include:

- Reduce the use of chemicals in RePeat process, thereby reducing the sulphur content in the end products
- Options to further increase the N concentration in the N-K concentrates
- Research on safety aspects in relation to H<sub>2</sub>S formation in products, in particular after mixing with other organic fertilisers

## 6.2 Ongoing Research & Development

- PPS project 'Meerwaarde Mest en Mineralen'. The RePeat process has been developed in a four-year PPS project in which Wageningen Research, GZV and Nijhuis Industries were involved.
- H2020 SYSTEMIC: Includes construction of the large-scale RePeat plant, optimisation of process performance, monitoring of the demonstration plant, product analyses and market development.

## 6.3 Technical Partners

- Wageningen Environmental Research – R&D
- Nijhuis Industries - R&D and Engineering
- Multiple technology supplies

## 6.4 IP, Patents, Copyrights, Brands

- No patent application was filed to protect the GENIAAL technology for N-K-concentrates
- A patent on the RePeat technology for P-recovery is foreseen

# 7 Staffing and Operations

## 7.1 Management (including Board) Organisation Chart

The company management team consists of a director and two managers responsible for the financial issues, including acquisition of feedstocks and disposal of digestate, and project development.

## 7.2 Staffing

Next to the management team, the company employs about 7 employees of which two process operators working in the plant and five truck drivers taking care of transportation of manure and digestate.

In 2019, one or two additional process operators will be hired to operate the nutrient recovery installations.

## 7.3 Training Plans

Current and future employees receive continuous training on the job.

## 7.4 Operations

While the anaerobic digestion is operated continuously, the nutrient recovery and recycling units are operated in one or two daytime shifts according to demand.

## 8 Investment and Funding

GZV's net investment for the NRR installations amount to € 3,300,000 plus about € 600,000 net contribution in grants from SYSTEMIC. The total CAPEX of the NRR equipment is some € 4,000,000.

The whole facility represents a total investment of about € 20,000,000 that has been financed by capital resources from the owner, bank loans and grants or minor loans from agencies.

Apart from the capital expenses for equipment, funds are spent on R&D and marketing of the products.

# 9 Financial Data/Projections

## 9.1 Profit & Loss Summary (2018 Result/2019 Projection)

Table 1: P & L summary including GENIAAL and RePeat in EUR

<b>Groot Zevert Vergisting (GZV)</b>	<b>Revenues</b>	<b>Expenses</b>	<b>Balance</b>
Substrates (feedstock)	780.000		780.000
Energy and Green Certificates	3.348.000	108.000	3.240.000
Product sales / savings	14.400		14.400
Consumables (chemicals, spare parts)		992.000	-992.000
Digestate & NRR product handling (storage, application)		449.800	-449.800
Operations (personnel, overhead, maintenance, repair)		546.000	-546.000
Amortisation (12 years biogas plant / 5 years NRR)		1.560.000	-1.560.000
	4.142.400	3.655.800	486.600
<b>EBITA (Earnings before interest, amortisation and tax)</b>		<b>2.046.600</b>	<b>EBITA Margin 49%</b>
<b>EBIT (Earnings before interest and tax)</b>		<b>486.600</b>	<b>EBIT Margin 12%</b>

## 9.2 Business Case without NRR

Revenues remain largely unchanged due to low expectations regarding prices for recycled products (struvite, N-K+S concentrate).

Nutrient recovery and recycling have a significant impact on the disposal/application cost of digestate: starting from a cost of € 2,376,000 it is reduced to € 781,000 after operating GENIAAL and to € 449,800 after operating RePeat. The savings are achieved by additional expenses of € 1,478,000 for the GENIAAL system and € 1,697,000 for the fully integrated NRR system.

Table 2. Comparison of expenses/revenues in EUR – base case, NRR with GENIAAL and NRR with RePeat in EUR

	Base Case without NRR	NRR GENIAAL	NRR GENIAAL + RePeat
Disposal/application of solid raw digestate (after NRR)			-381.000
Disposal/application of liquid raw digestate (after NRR)		-781.000	-17.600
Disposal/application of organic fertilising product			-51.200
Disposal/application of raw digestate (before NRR)	-2.376.000		
Human resources costs	-240.000	-240.000	-240.000
Maintenance & consumables	-360.000	-360.000	-360.000
Amortisation (biogas plant, 12 years)	-900.000	-900.000	-900.000
Electricity consumption	-108.000	-108.000	-108.000
GENIAAL / RePeat fixed costs (amortisation, personnel)		-870.000	-966.000
GENIAAL / RePeat variable costs (maintenance, consumables)		-518.000	-632.000
<b>Expenses</b>	<b>-3.984.000</b>	<b>-3.777.000</b>	<b>-3.655.800</b>
Revenues from energy sales	3.348.000	3.348.000	3.348.000
Revenues from gate-fees	780.000	780.000	780.000
Revenues from fertiliser product sales			14.400
<b>Revenues</b>	<b>4.128.000</b>	<b>4.128.000</b>	<b>4.142.400</b>
<b>EBIT (Earnings before interest and tax) / %</b>	<b>144.000</b>	<b>351.000</b>	<b>486.600</b>



# 10 Business Case Analysis

The sources of revenues amounting to 4,142 million Euro are quite balanced between gate-fees (0.78 million Euro), biogas supplies to FrieslandCampina (2.6 million Euro) and power supplies to the grid (0,75 million Euro). Because of the revenue mix and the direct supply of biogas to the dairy plant the dependence on subsidies is lower than for comparable plants.

The downside of the relevant gate-fees for manure are high costs for the digestate – by far the single largest cost position of the base-case amounting to 2,38 million Euro. It is quite obvious that plant owners selected this cost position to improve the business case due to paying € 22.00 for each of the 108,000 tons of digestate that needs to be disposed of.

The solutions aim at significantly reducing the amount of raw digestate which needs to be disposed of or applied to crop land. In a first step (GENIAAL), the raw manure is separated to water, a liquid N-K concentrate and a mineral rich, solid organic fertilising product. Water discharge and application of the liquid N-K concentrate cost much less than managing raw digestate because it can be discharged to the sewer system (water) and used (N-K product) in the vicinity of the plant. The remaining 20,000 tons of solid organic fertilising product still have a similar disposal cost as the raw digestate, but the quantity has been reduced to 1/5 of the original amount and the cost to about 1/3 (0.78 million Euro).

The second step aims at fractionating the remaining 20,000 tons (at least a large part of it) to P-depleted organic soil improver, struvite and purified water (e.g. for irrigation). The step almost halves the cost of handling and discharging the remaining effluents and reduces the effluent mass flow further. The second step is not yet designed to treat the whole amount of solid effluents, hence leaves room to unlock additional savings potential during later stages.

As can be seen in the tables, direct revenues from recycled products don't have a relevant impact on the business case. Currently, the focus is on reducing the costs. However, GZV pursues a strategy for selling the recycled products to selected niche markets like designing the nutrient (P) depleted solid organic fraction for use as potting soils. GZV management has also realised that developing products for acceptance and demand by determined players needs extra efforts and has a cost – partly covered by SYSTEMIC. Even if this insight does not look like a major milestone it must be emphasized due to only few recyclers paying attention to product marketing and due to the almost total absence of public funding for this purpose.

In the business case of GZV, revenues from recycled products should still have a substantial upside potential. If the fertilising products could be sold at prices anywhere near to the current market prices for nutrients in mineral fertilisers, only the 2,400 t/a of struvite could generate some 400,000 Euro per year. Similar revenue potentials may be hidden in the N-K concentrate and the P-depleted organic fraction, if it can be sold as potting soil. However, any application of the recycled materials as chemical product (in contrast to remaining waste) will require REACH application. It is expected, that the European Commission will exempt digestate from REACH registration similar to compost (to be published in Qu3/2019) but this exemption will most likely not apply to products derived from digestate.

However, revenue potentials would only materialise if targeted marketing actions are taken. The cost of marketing a new product may be equal to or even exceed CAPEX and OPEX of producing the recycled product. The supplier may be requested to advertise the new product, to employ field advisers directly talking to farmers, to provide storage facilities close to the areas where the product will be applied and similar marketing, sales and logistics provisions. Hence, marketing the recycled products to higher value markets may improve the business case but also has the potential to drive GZV to expenses that do not generate a relevant return.

To sum up: GZV is operating the plant in a challenging environment with nutrient supplies exceeding the sustainable demand, reflected in relevant gate-fees but also in very high costs for digestate disposal and application. The challenge has been addressed by installing a comprehensive nutrient recovery and recycling system consisting of two units called GENIAAL and RePeat, the former referring to the liquid fraction and the latter to the solid fraction after mechanical separation. The business case evaluation shows that the NRR systems improve earnings before interest and tax (EBIT) by more than 200% and make the business case more resilient.

15 Annex 5 Business Case Evaluation  
Green Create W2V Ltd.



# Business Case Evaluation

---



# Green Create W2V Kent Ltd

---



## **Content**

1	Executive Summary .....	III
2	Company Description .....	V
2.1	Promoters and Shareholders .....	V
2.2	Advisors .....	V
2.3	Products and Services .....	V
	Long Term Aim of the Business.....	VI
3	SWOT Analysis .....	VII
4	Market Analysis .....	VIII
4.1	Target Market.....	VIII
4.2	Market Trends .....	VIII
4.3	Competitive Advantage.....	VIII
4.4	Benefits to Clients.....	IX
5	Marketing/Sales Strategy .....	X
5.1	Pricing .....	X
6	Research and Development .....	XI
6.1	Technical Partners.....	XI
6.2	IP, Patents, Copyrights, Brands .....	XI
7	Staffing and Operations .....	XII
7.1	Management (including Board) and Operational Staff .....	XII
7.2	Operations .....	XII
8	Investment and Funding .....	XIII
	Sources of Finance: .....	XIII
9	Financial Data/Projections .....	XIV
9.1	Profit & Loss Summary .....	XIV
9.2	Business Case without NRR .....	XIV
10	Business Case Analysis .....	XVI

# 1 Executive Summary

This business case evaluation covers RIKA Biofuels / Green Create W2V, a mesophilic anaerobic digester (AD) at Fridays' Knoxbridge Farm, Frittenden, Cranbrook, Kent, United Kingdom, currently under construction with a total annual substrate treatment capacity of 60,000 t. Planned to process poultry litter and straw.

*Table 1.1 Rika Biofuels / Green Create W2V plant characteristics*

Date of commissioning	2019
Annual substrate processing capacity / to process	60,000 t / 57,500 t (55 kt poultry litter / 2,5 kt straw)
Installed electric capacity (IEC)	1.8 MW
Installed biomethane capacity	450 m <sup>3</sup>
Digester volume	16,000 m <sup>3</sup>
Annual biogas output / biogas per t of feedstock	7.2 Mm <sup>3</sup> / 125 m <sup>3</sup> /t
Annual electricity net-output (fed to the grid)	3,750 MWh (4,125 MWh <sub>heat</sub> )
Annual bio-methane output	2,8 Mm <sup>3</sup>
Digester type	Mesophilic mixed plug-flow digester (system DVO)
Nutrient recovery & recycling (NRR) facilities	N-stripper and reactor Modified dissolved air flotation (DAF) Screw press for solid/liquid separation
NRR Products	Ammonium sulphate Hygienised P-rich digestate
Framework conditions relevant to the business case	Moderate livestock density in the region Products can be used in the region Plug-flow digester

The plant will be owned and operated by Green Create W2V Ltd. The plant technology is provided by Rika Biofuel Developments Ltd with key elements based on DVO's patented Linear Vortex™ digester technology. The case description is conceived from the developer's point of view.

Rika Biofuel Developments Ltd (RBD) is a specialist developer of AD plants both in the UK, the EU and abroad. RBD's international outlook and experience of developing international biogas projects will allow the team to maximise on the export opportunities that will arise from the successful implementation of Europe's first-of-its-kind Green Create W2V plant. Directors James Fenwick and Harry Hoskyns Abrahall have experience of developing multiple biogas projects in the UK having built 41 MW<sub>el</sub> crop-based plants under the banner of Hallwick Energy Ltd and a further number of projects under development under Rika. The team has developed and operated biogas plants in the UK in partnership with farms and agricultural estates, providing debt and equity investment packages to fund the projects, either as the sole investor or in a joint venture partnership, tailoring the partnership structure to each individual project to ensure that all partners benefit from the plants' success.

The plant shall convert 55,000 tonnes per annum of poultry manure and 2,500 tonnes of straw to about 900m<sup>3</sup> biogas per hour which shall be primarily upgraded and injected into the gas grid with around 230m<sup>3</sup> per hour used to run an onsite CHP engine that will provide the required process heat and electricity requirements. As part of the plant's design nutrient recovery and recycling (NRR) technologies will be employed producing valuable by-products

from the installation such as concentrated digestate as organic fertilising product and a mineral ammonium sulphate solution.

There is an opportunity to improve the business case through the sale of the nutrient rich by-products. Potential off-takers have been identified from the local farming and contracting community for the digestate and ammonium sulphate and these discussions have informed the design of the nutrient recovery equipment. In future higher value markets should be realised by further processing and/or packaging of the by-products.

The Green Create Project will be funded through a combination of debt and equity.

# 2 Company Description

## 2.1 Promoters and Shareholders

- Promoters
  - Rika Biofuel Developments Ltd
  - Green Create W2V Ltd
- Management structure and areas of responsibility
  - Rika Biofuel Developments Ltd - Project Developers
  - Green Create W2V Ltd - Funders and Development Support
- Shareholders in Green Create W2V Kent Ltd
  - Green Create W2V Ltd - Funders and Development Support - 100%

## 2.2 Advisors

- Legal: MFG Solicitors
- Technical
  - Sweco - Designers and EPCm construction management
  - Mooney Kelly- Quantity Surveyors
  - Sweco- Civil Engineers
- Environmental – E4 Environment
- Planning- DHA Planning

## 2.3 Products and Services

### **Background to the Project Development**

Green Create Ltd has about 55,000 tons of poultry manure for conversion to energy and fertilising products. Poultry manure is a high nitrogen containing feedstock requiring nitrogen separation to avoid dilution of the feedstock and significantly increasing the non-organic mass flow.

Particularly suitable for digesting poultry manure is DVO's patented two-step, mesophilic mixed plug-flow system with a guaranteed retention time of around 20 days. Due to the first-in / first-out principle of the system, all particles have the same retention time. Acidification and methanation are separated allowing a low pH in the first chamber and a high pH (8.5) in the second chamber, providing favourable conditions for ammonia (N) stripping without using chemicals or energy for raising the pH-value.

Green Create has acknowledged the potential benefits of the solution proposed by RIKA Biofuels Development Ltd and will implement DVO's patented plug flow digester technology and demonstrate that chicken manure can be treated in a sustainable way while recycling nitrogen (N) and phosphorous (P) and reducing GHG emissions

Rika promotes DVO technology throughout Europe and is currently building two plants using this technology - one of which is Green Create W2V Kent Ltd

## Benefits and Features

The selected digestion process not only enhances the nutrient value in the manure, it also removes the odour, kills most pathogens (including E-Coli) and changes the state of the nutrients so they can be taken up by a growing crop. Particular advantages of the DVO process are:

- More effective digestion of manures
- Effective nutrient recovery without chemicals
- Competitive pricing
- No moving parts in digester
- Near-complete bacterial (pathogen) kill

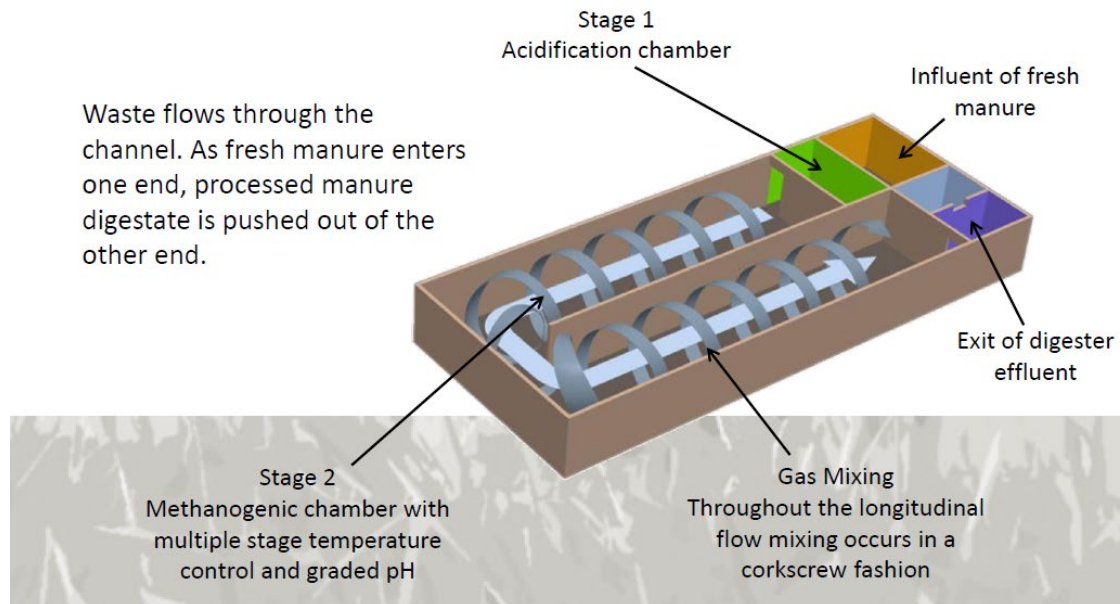

**Figure 1 Process and layout of the DVO digester at Green Create**

## Future Project Developments

- Wijster Plant in Netherlands (150,000 tonnes per annum poultry manure)
- EU: Opportunities for 3-4 digester projects in Flanders, as well as a further project in the Netherlands
- Non-EU: 3-4 digester projects in the Ukraine and a not yet predictable number of cow manure digester projects in India

## Long Term Aim of the Business

The development of 15-20 DVO digester and nutrient recovery projects in Europe and a not yet predictable number of projects in selected non-European countries over the next 5 years.

Apart from the present project, RIKA has a sales pipeline of 3 follow-on projects in the EU:

- Rika Green Park Wijster, Netherlands
- GZI Project, Netherlands
- Ghent Project, Flanders



### 3 SWOT Analysis

<b>Strengths</b> <ul style="list-style-type: none"><li>• Simple, robust NRR design</li><li>• Low CAPEX for NRR</li><li>• Low OPEX</li><li>• No moving parts within Digester</li><li>• Revenues from input and output</li><li>• All products are used in the vicinity</li><li>• Up to 99,9% pathogen removal</li><li>• High input flexibility</li></ul>	<b>Weaknesses</b> <ul style="list-style-type: none"><li>• US technology solution that must be implemented for the first time in Europe</li><li>• No AD without NRR</li></ul>
<b>Opportunities</b> <ul style="list-style-type: none"><li>• Sale of high quality, nutrient rich, pathogen free digestate and ammonium sulphate</li><li>• Added value through packaging digestate from the plug flow reactor design that is not available to CSTR technologies</li></ul>	<b>Threats</b> <ul style="list-style-type: none"><li>• Total dependency on local poultry farm</li><li>• Unforeseeable regulatory changes</li></ul>

# 4 Market Analysis

## 4.1 Target Market

The Green Create project addresses available poultry manure as feedstock, biomethane as main energy product and concentrated N-P-K fertilising products as recycled by-products.

Biomethane can be injected into the gas grid, compressed or liquefied and used as fuel for cars, trucks, and buses. In the present case biomethane is injected to the gas-grid through a contract with an established gas trader: Barrow Shipping

Barrow Shipping holds a UK Gas Shipper Licence and creates value for biomethane producers through:

- Purchasing biomethane
- Offering a flexible service with no restriction on volumes
- Optimising transportation discounts
- Separating Green Gas Certificates from gas production
- Marketing Green Gas Certificates to maximise their value
- Membership of the Biomethane Producers Club

The UK's first two commercial biomethane injection schemes have signed up and are now members of the Biomethane Producers Club.

The concentrated N-P-K digestate will be sold via local solid fertilizer contractor(s) at an estimated sales price of GBP 5/tonne

Ammonium Sulphate will also be sold to local market at an estimated sales price of GBP 30/tonne in the form of blends with N-P-K digestate to add value.

## 4.2 Market Trends

- Future predictions
  - UK aims at using biomethane for 3% of the domestic gas supplies by 2020
  - By removing 50,000 tonnes of raw poultry manure from the local market Green Create may actually create a market for processed N-P-K digestate.
- Drivers such as demographic changes, economic and legislative factors
  - Being close to London the market for solid organic fertilizers is saturated due to availability of huge quantities of post digested sewage sludge.
- Implications for the product or service
  - May suppress potential price for digestate and ammonium sulphate
- Plans to meet future demands and changes in the market
  - Green Create may add driers to further concentrate nutrient loadings and give potential of selling digestate via the retail market (e.g. garden centres)

## 4.3 Competitive Advantage

The advantage of DVO's technology package is

- Guaranteed retention time of about 20 days. In competitive systems, not all of the waste is in the digester long enough for complete digestion to occur. This means both energy and pathogens remain in the waste.

- Consistent process temperature due to DVO digesters are built underground, taking advantage of the earth's natural insulating properties to keep microorganisms functioning at their highest levels of efficiency.
- Patented, gas-driven mixing system providing for more complete biodegradation of wastes. Digesters are also less expensive to build and operate, avoiding the power needed to move the machinery in a conventional mixed digester.
- The DVO system can remove up to 90% of phosphorus and 75% of nitrogen ammonia (limiting ammonia emissions) from organic waste, converting it to a stable, commercial N-P-K fertiliser.

On top of the system inherent features, Green Create benefits from specific, feedstock and NRR related advantages like

- High N-P-K for recycled fertilising product because of feedstock being poultry manure
- High dry matter concentration of 25-26% in the product
- Ability to blend ammonium sulphate and produce a bespoke recycled fertilising product
- Further up-side potential for NRR products by addressing selected niche markets

## 4.4 Benefits to Clients

Clients, i.e. owners and operators of RIKA Biofuel Development projects benefit from all the bespoke system advantages.

Clients of the recycled fertilising products benefit from:

- Increased efficiencies
  - A higher N-P-K product allows farmers to apply required fertilizers with fewer field passes
- Product safety (almost pathogen free) and nutrients ready for crop uptake
- Saving money
  - Reduced diesel costs for farmers spreading digestate

# 5 Marketing/Sales Strategy

The marketing and sales strategy of RIKA Biofuels Developments is based on the mentioned advantages of DVO AD systems and offering comprehensive project development services including:

- Feasibility studies and business case development
- Broad design principles
- Financing
- Planning and permitting
- Detailed design and pre-development work
- Construction
- Operations

The marketing and sales strategy of Green Create is based on outsourcing the tasks to experienced contractors:

- Bio-methane feed-in to the grid is outsourced to Barrow Shipping
- Recycled fertilising products are sold through a local solid fertilizer contractor.
  - Signing an initial 12-month off-take agreement for digestate and ammonium sulphate
  - Exploring other higher value opportunities in year 1 when we have actual samples to demonstrate
  - In year 2 about 20% of the total volumes (300 tonnes) will be reserved to promote recycled product to retail buyers.

A good example for a recycling product from DVO digesting plants is Magic Dirt™, a certified organic premium potting soil that was introduced by Cenergy USA in 2014 as a sustainable alternative to peat moss. Potting soil is apparently a good choice for getting added value from digestate-based products.

## 5.1 Pricing

As long as conventional farming and consequently mass fertilising product markets are addressed with the digestate-based products, prices are set by supply and demand and, more precisely, by the off-takers that are contracted for selling the product.

Consequently, the sales price for the concentrated fertilising product is expected at GBP 5/t and the price for the mineral ammonium sulphate at GBP 30/t. Both products are blended to a customised, organic N-P-K fertiliser with nutrient concentrations adjusted to the soil and crop requirements of local farmers.

Due to the possibility of selling the N-P-K products in the region, sales prices are not limited by relevant handling and transport costs. In contrast to other demonstration plants, fertilising products are directly contributing to the revenues of Green Create. Recycled product sales add about GBP 240,000 per annum to the Profit & Loss account of the plant.

# 6 Research and Development

Green Create does not have an own R&D department. No research activities are consequently planned or performed at the biogas plant site.

Rika Biofuels Development does not have a specific R&D department either, but the company has an innovative management and directors closely monitoring the market and its needs and innovation options. Ideas and hypothetical solutions are discussed with the technical partners and solutions are developed by their R&D departments in cooperation with universities and during RIA projects like SYSTEMIC.

The solution developed for Green Create has been developed by the technical partners listed below.

## 6.1 Technical Partners

- AD and NRR technology: DVO Inc., Chilton (WI), USA
- Biogas Upgrading: DMT Environmental Technology, SN Joure, The Netherlands
- Straw Bio-extrusion: Lehmann Maschinenbau GmbH, Pöhl, Germany
- Straw Handling: Rika Biogas Technologies, Hillingdon Heath, Middlesex, UK

## 6.2 IP, Patents, Copyrights, Brands

IP is held by various technology and package providers:

- AD and NRR technology: DVO
- Biogas Upgrading: DMT
- Straw Bio extrusion: Lehmann GmbH
- Straw Handling: Rika Biogas Technologies

# 7 Staffing and Operations

## 7.1 Management (including Board) and Operational Staff

- The biogas plant will be managed day to day through a full operations and maintenance contract with a company called Birch Energy.
- Rika Biofuel Developments will manage aspects of the plant's administration and financial reporting.

## 7.2 Operations

Continuous operations are outsourced to Birch Energy. Birch Energy is part of the Singleton Birch Limited group of companies and was originally set up to develop renewable energy projects at the main Singleton Birch industrial site at Melton Ross, North Lincolnshire. Using the experience gained from the initial on-site projects, the opportunity to develop external energy projects was quickly realised.

Birch Energy currently has three Anaerobic Digesters in operation, with further projects in planning or at the feasibility stage, one of them being Green Create.

The company provides a staff of two for the whole year continuous 24/7 operations and maintenance.

- Premises
  - Address: Knoxbridge Farm, Frittenden, Kent, TN17 2BT
- Equipment
  - Biogas plant incorporating:
    - DVO digester
    - DMT biogas upgrading and gas to grid injection facility
    - Solids separation plant
    - Ammonia Recovery plant
    - Ancillary equipment

# 8 Investment and Funding

CAPEX for equipment and associated development fees for the Green Create anaerobic digestion plant including the equipment for biogas upgrading to pipeline grade biomethane and nutrient recovery and recycling is € 15,185,000.

## **Sources of Finance:**

- Promoters' funds: € 2,435,000
- Bank lending: € 12,750,000
- Investment already received: All of the above.

# 9 Financial Data/Projections

## 9.1 Profit & Loss Summary

Table 9.1 P & L summary in EUR (according to business plan, operations at full capacity)

<b>RIKA Green Create</b>	<b>Revenues</b>	<b>Expenses</b>	<b>Balance</b>
Substrates (feedstock)	372.333		372.333
Energy and Green Certificates	3.503.444	197.000	3.306.444
Product sales / savings	273.750		273.750
Consumables (chemicals, spare parts)		303.700	-303.700
Digestate & NRR product handling (storage, application)		650.000	-650.000
Operations (personnel, overhead, maintenance, repair)		483.666	-483.666
Amortisation (20 years)		759.250	-759.250
	4.149.527	2.393.616	1.755.911
<b>EBITA (earnings before interest, amortisation &amp; tax)</b>		<b>2.515.161</b>	<b>EBITA Margin 61%</b>
<b>EBIT (earnings before interest and tax)</b>		<b>1.755.911</b>	<b>EBIT Margin 42%</b>

## 9.2 Business Case without NRR

Running a 100% poultry manure plant without nutrient recovery technologies would be a concept Rika would never attempt due to the risk of creating a vast water requirement and a huge effluent issue that could not be managed economically. However, in an attempt to quantify the benefits of using the NRR tech on this project we have run some scenarios attempting to quantify what would be the revenue and cost impacts of not using NRR. The main influencing factors on the business case would be as follows:

1. No revenue stream for separate fertilizer products; high P digestate and ammonium sulphate
2. Much higher water usage to dilute incoming manure, adding cost
3. Cost of disposing of large quantities of effluent/liquid digestate
4. Reduced capex from NNR install costs not being utilized
5. Reduction in polymer and sulphuric acid usage



Taking into account the impact factors, the comparison headline figures and return profiles for the two scenarios are presented: 'With NRR' and 'Without NRR'

Table 9.2 Business case with and without NRR

RIKA Green Create	With NRR in €	Without NRR in €	Difference in €
Revenues from energy, gate-fees, NRR	4.149.527	4.000.000	-149.527
Digestate disposal (application)	-650.000	-1.800.000	-1.150.000
Consumables (chemicals)	-303.700	-200.000	103.700
Operations	-483.666	-450.000	33.666
Amortisation (20 years)	-759.250	-311.250	448.000
EBIT	1.755.911	1.041.750	-714.161

# 10 Business Case Analysis

The Green Create W2V business case represents a completely new project, developed and implemented under the current regulatory framework of the UK. This means green certificates or feed-in tariffs that are much closer to market prices than previous contracts, requiring very efficient, competitive biomass-to-energy solutions and favouring conversion to biomethane.

While looking out for attractive business opportunities suitable for RIKA Biofuel's anaerobic digestion solutions, the team identified large amounts of poultry litter that were not in the focus for conversion to biogas due to its high nitrogen content inhibiting conversion in standard Continuous Stirred-Tank Reactor (CSTR) anaerobic digesters. After the British government finally has agreed on the legal and economic framework for biomass-based renewable energy, RIKA started to develop the project based on converting poultry litter and straw to 900 m<sup>3</sup>/h of biogas, most of which - 670 m<sup>3</sup>/h - upgraded to biomethane and 230 m<sup>3</sup>/h converted to electricity to cover the heat and power requirements of the plant and feed-in to the grid the subsidised – albeit small - fraction.

The expected 4.15 M€ of total revenues are based on revenues from biomethane supplies (3.2 M€), power supplies (0.3 M€), gate-fees (0.37 M€) and fertilising product sales (0.27 M€). It is the most profitable business case due to three out of four in- and outflows producing revenues and modest operations and maintenance costs.

Nonetheless, revenues largely depend on biomethane (77%) and power (7%) supplies contributing 84% to the total revenues. Regardless of upgrading the digestate-based fertilising products to N-P-K concentrate and ammonium sulphate, handling and application (outsourced to a fertiliser contractor) of these products still exceeds the sales revenues by more than a factor two.

Notwithstanding the considerable recycling product handling and sales costs, the business case is highly profitable and produces a remarkable ROI of 15.6% and an EBIT margin of 42%. It is also highly resilient, if biomethane supplies produce the projected revenues. Currently, the price of biomethane is still subsidised but under future scenarios with higher prices for fossil fuels and a relevant CO<sub>2</sub> tax imposed, the price may come much closer to market prices.



The business case remains profitable regardless of operating the plant with or without NRR, although running the plant without NRR would be meaningless. The digester design provides optimal pH-conditions for stripping nitrogen and producing a N-P-K concentrate and the project would not have been approved without the corresponding features. In case of not receiving gate-fees for the feedstock or in case of not achieving revenues from product sales, the business case would still be profitable. In addition, a contingency is foreseen in the business plan in case of certain parameters not meeting the design values.

Similar to the other SYSTEMIC business cases, profits could still be significantly enhanced by closing the gap between the market price of nutrients in conventional fertilisers and the market value of recycled fertilisers.

Magic Dirt™ (<https://www.magic-dirt.com/>), a potting soil produced exclusively from DVO's digestate in the USA and sold by Walmart in 2,500 outlets is an excellent example for how a digestate-based product could be marketed.

Magic Dirt™ is formulated with anaerobically digested organic fibre and composted forest products. It is not compost, and it contains no peat moss, coir, perlite or vermiculite. The products are certified under the USDA's BioPreferred Program

as 100% BioBased (all organic ingredients). This does not mean that the product would be accepted for organic farming in Europe, but it may be a very viable pathway for achieving a high market value – the retail value in the US is about 700 USD/ton.

The barriers for producing products like Magic Dirt™ from SYSTEMIC demonstration plants are most likely the number of supply sources and the homogeneity of products – DVO has more than 120 similar plants using mainly cow manure as feedstock and consequently producing a large quantity of a

quite homogenous product. Walmart and blenders would probably not be interested to start such an activity with only one source of supply. But as soon as a project pipeline would demonstrate growing potential, similar business cases should be possible in Europe.

Conclusively, the RIKA Biofuel and Green Create W2V demonstration plant shows that by providing a stable economic and regulatory framework with relatively modest incentives, highly profitable business cases could be developed and effectively contribute to a stable renewable energy supply, a transport fuel for heavy duty vehicles with low or zero greenhouse gas emissions and production of recycled fertilising products that reduce the environmental burden of livestock farming.

## 16 Annex 6 Business Case Evaluation A-Farmers Nurmon Bioenergia Ltd.



# Business Case Evaluation

---



## A-Farmers Nurmon Bioenergia Ltd

---

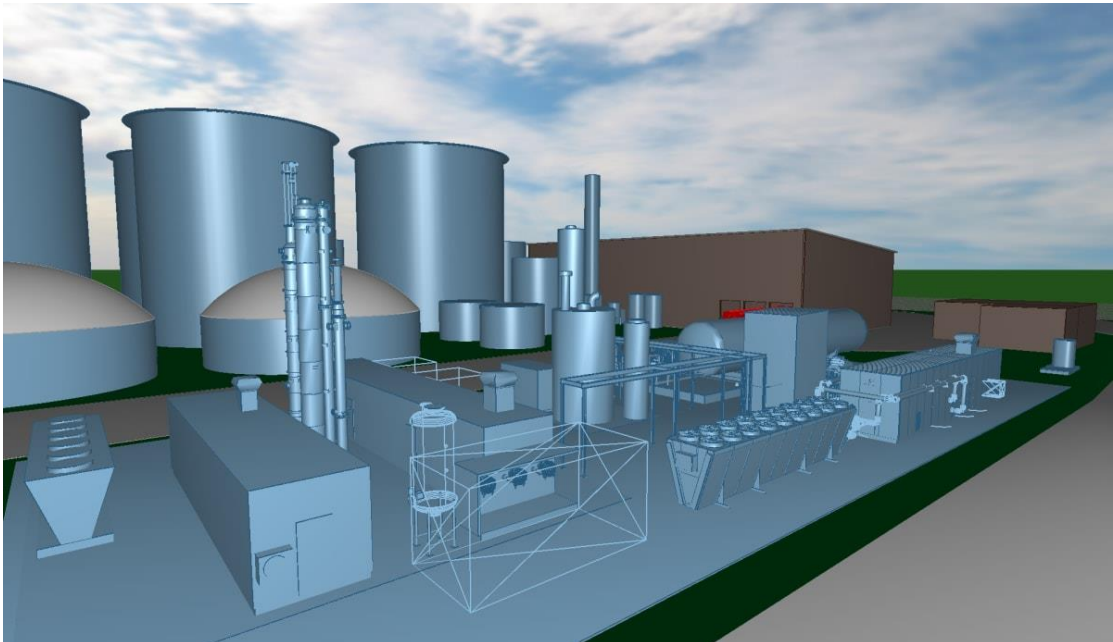

## Content

1	Executive Summary	III
2	Company Description	IV
2.1	Promoters and Shareholders .....	IV
2.2	Advisors .....	IV
2.3	Products and Services .....	IV
2.4	Long Term Aim of the Business.....	IV
2.5	Objectives.....	V
3	SWOT Analysis	VI
4	Market Analysis	VII
4.1	Target Market.....	VII
4.2	Market Trends .....	VII
4.3	Profile of Competitors .....	VII
4.4	Competitive Advantage.....	VIII
4.5	Benefits to Clients.....	VIII
5	Marketing/Sales Strategy	IX
5.1	Marketing Strategy .....	IX
5.2	Revenue Sources (NRR).....	IX
5.3	Sales Strategy .....	IX
5.4	Pricing .....	X
5.5	Marketing and Communications Strategy .....	X
6	Research and Development	XI
6.1	Research and Development.....	XI
6.2	Technical Partners.....	XI
6.3	IP, Patents, Copyrights, Brands .....	XI
7	Staffing and Operations	XII
8	Investment and Funding	XIII
9	Financial Data/Projections	XIV
9.1	Business Case with NRR.....	XIV
9.2	Business Case without NRR .....	XIV
10	Business Case Analysis	XV

# 1 Executive Summary

A-Farmers / Nurmon Bioenergia Ltd., a mesophilic anaerobic digester (AD) in Seinäjoki (80 km southeast of Vaasa), South Ostrobothnia, Finland currently under construction with a total annual substrate treatment capacity of 240,000 t. Planned to process manure, industry by-products and plant biomass.

*Table 1.1 A-Farmers / Nurmon Bioenergia plant characteristics*

Date of commissioning	2021
Annual substrate processing capacity / to process	240.000 t / 210.000 t (90 kt manure, 100 kt industry by products and 20 kt plant biomass)
Installed electric capacity (IEC)	None
Installed biomethane capacity	~20 t of bio-LNG/d
Digester volume	~20 000 m <sup>3</sup>
Annual biogas output / biogas per t of feedstock	15 Mm <sup>3</sup> / 50 – 60 m <sup>3</sup>
Annual electricity net-output (fed to the grid)	-
Annual bio-methane output	9 Mm <sup>3</sup> (90,000 MWh) bio-LNG
Digester type	Mesophilic Continuous Stirred-Tank Reactor (CSTR)
Nutrient recovery & recycling (NRR) facilities	Centrifuges for solid/liquid separation, N-stripper and evaporator
NRR Products	Separated solid fraction of digestate, NPK- (or PK-concentrate and ammonium sulphate)
Framework conditions relevant to the business case	Moderate livestock density in the region All feedstock converted to bio-LNG as a transport fuel

The SYSTEMIC outreach plant is owned by Nurmon Bioenergia Ltd., a subsidiary of Heikas Ltd. (90%) and Atria Finland Ltd. (10%). The project matches the Finish political, legal and economic framework promoting the Circular Economy and the use of liquid biomethane for long-range, heavy duty transport.

The Nurmon Bioenergia plant is designed to process about 210,000 annual tons of biowaste, about half manure and half food industry by-products. Whereas most by-products from food industry are supplied with a gate-fee, manure is taken-in for free and some by-products from other industries must to be paid. All-in-all, feedstock contributes to the plant revenues.

The main revenue flow is generated by liquid biomethane (bio-LNG) to be sold to gas providers operating in Finland. There could be several new gas operators in the beginning of the next year when the Finnish gas network is opened via Baltic Connector. Already now, gas could be distributed across the country for use as transport fuel. The use of bio-LNG as transport fuel is strongly promoted by Nordic countries. Major truck suppliers offer adapted heavy-duty trucks with an autonomy of up to 1600 km, same performance and comfort as the equivalent diesel models and – most important for the transport industry – the same cost per km. This approach seems to be very attractive due to allowing BIO-LNG production and use with modest subsidies and use of an alternative, low carbon footprint fuel without major infrastructure investments.

The business case analysis is based on its business plan. The plant will be operational by the end of 2020. However, the calculations are quite robust since financing institutions required pre-contracts to provide the required funds.

Whereas Nurmon Bioenergia has a – among SYSTEMIC demonstration plants – unique energy supply approach, implemented nutrient recovery and recycling (NRR) technologies are similar to other plants with solid/liquid separation, an organic fertilising product and dischargeable water. In contrast to plants in Flanders and The Netherlands, the fertilising products can be used in the region. NRR is driven by the need for long-term storage of digestate before it can be applied to the climatic and regulatory constraints in Finland. Without NRR, the business case would not be viable due to additional expenses, mainly for storage, of some 0.5-1 M€ which would eat-up half or all of the projected profit.

## 2 Company Description

### 2.1 Promoters and Shareholders

- Promoters: A-Farmers Ltd and Atria Finland Ltd,
- Management structure and areas of responsibility:
- Main responsible person: Mr. Jyrki Heilä/Heikas Ltd
- Board: Chairman of the board Jyrki Heilä, other members Jari Kaskinen/Heikas Ltd and Tapani Potka/Atria Finland Ltd.
- Shareholders names, no. of shares, % shareholding and cash investment to date: Heikas Ltd 90% and Atria Finland Ltd 10%. Negotiations ongoing with some other companies. The aim is to keep SME status (ownership of big companies <25%).

### 2.2 Advisors

- Project team uses experienced advisors for financial evaluations, legal issues as well as technical and project development.

### 2.3 Products and Services

- Management of manure/nutrient surpluses of farmers
- Provide recycled nutrients in reasonable price into market, also for organic farming
- Produce renewable traffic fuel (liquefied biogas (LBG)) especially for heavy traffic

### 2.4 Long Term Aim of the Business

Development of nationwide economically viable bio business network which meets tightening environmental criteria in the long run and decreases environmental footprint of Finnish food and thus, enhances acceptability of meat production in national market as well as overall Finnish food competitiveness in international market. The future network will consist of 4 – 5 plant ecosystems which are adapted to local conditions and thus could include different process combinations.



## Development of Ecosystem

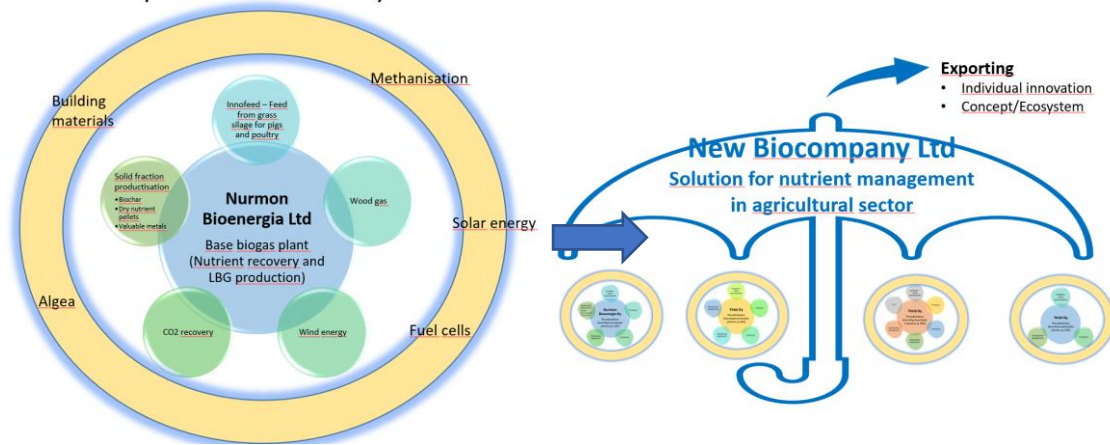

**Figure 1. Development of network of locally integrated ecosystems for management of nutrient in agricultural sector (left figure: inner blue circle include the operations of Nurmon Bioenergia Ltd which will be built in the first phase = base biogas plant, the next ring of blue and green balloons reflect examples of possible processes which have been seen technically and economically viable in the next phase, outer circle contains possibilities to be included in the long-term).**

## 2.5 Objectives

- Investment aid decision: 12/2018
- Finalisation of zoning, environmental permit, funding, building permit: 6-9/2019
- Investment decision: 9/2019
- Building project: 9/2019-11/2020
- Plant ramp-up: 11/2020 – 3/2021
  1. Biogas process
  2. Biogas upgrading and liquefaction
  3. Nutrient recovery processes

### 3 SWOT Analysis

<p><b>Strengths</b></p> <ul style="list-style-type: none"> <li>• Animal manure is a well available raw material</li> <li>• Revenues from gate-fee</li> <li>• No costs from digestate disposal</li> <li>• Evaporation is an existing, proven technology for digestate</li> <li>• Dischargeable wastewater</li> <li>• Products can be used regionally</li> </ul>	<p><b>Weaknesses</b></p> <ul style="list-style-type: none"> <li>• No gate-fees available from manure, dependency on energy prices</li> <li>• Low amount of gas fuelled cars and bio-LNG using trucks, market development rate?</li> <li>• Additional storage capacity due to fertiliser use limitations</li> </ul>
<p><b>Opportunities</b></p> <ul style="list-style-type: none"> <li>• Animal manure is very low utilised resource so far &gt; possibility to copy concept in Finland and provide demonstration plant for technology suppliers with international interest</li> <li>• Recycled nutrient products are suitable for organic farming which is an increasing sector</li> <li>• Potential for increasing bio-LNG use</li> <li>• Additional revenues from recycled products</li> </ul>	<p><b>Threats</b></p> <ul style="list-style-type: none"> <li>• Fluctuation of energy prices</li> <li>• Low price of LNG, customers readiness to pay enough extra for bio-based fuel</li> <li>• Unforeseeable regulatory changes</li> </ul>

# 4 Market Analysis

## 4.1 Target Market

Manure management service: Amount of manure (pigs, cow, poultry and fur animals) in the area is 2 000 000 tons, need for the biogas plant 100 000 – 200 000 tons. Amount of manure will be stable or slightly increasing. In any case, tightening environmental regulations will increase the need for manure management.

Nutrient products: Available field hectares in the area are 220 000 hectares, need is for ~20 000 hectares. Thus, the size of the market is not limiting factor. Interest to recycled nutrients are generally increasing. Especially, organic farming needs efficient nutrient products. Main user will be agriculture. Some of the solid fraction can be sold as raw material for manufacturing growing media and soil amendments.

Liquefied biogas: Basically infinite. However, the BIO-LNG, and also LNG, market is just emerging. First, the BIO-LNG will be sold mainly into industrial use (replacing, e.g., oil, LPG), and after five years, mainly for the traffic fuel use. Supposedly, bio-LNG will be sold for customers as a mixture of LNG and bio-LNG as the price of LNG is much lower than reasonable price of bio-LNG. However, customers are willing to “green” their image by buying partly bio-LNG in addition to LNG.

## 4.2 Market Trends

The market is characterised by a growing need for renewable energy due to the climate change, and especially after the latest IPCC reports. Finland has quite ambitious targets for replacing fossil fuels in transport sector and biogas is considered as an important source of energy, especially for heavy traffic. The challenge is that LNG is quite cheap (~60 €/MWh) and Nurmon Bioenergia needs close to 100 €/MWh from bio-LNG. However, the company believes that the required price for bio-LNG could be attained through some modest support schemes due to the need of decreasing emissions and enhancing the public reputation of companies. During the next five years, energy taxes will be also reviewed, and the aim is to make renewable energy more attractive compared to fossil energy.

The market of traditional organic fertilisers derived from sewage sludge (digestate and compost) has been declined very fast during the last two years. Several grain producers have been denied using sewage sludge based fertilisers. This has improved the market for organic fertilisers from less controversial origins, for instance manure and food waste.

**Since Nurmon Bioenergia is not going to use sewage sludge as feedstock, nutrients from the plant should be more desirable.**

Moreover, there is growing need and willingness for solutions of manure management and nutrient recycling, also in governmental level. Next CAP period will supposedly encourage this as well. However, the preparation of regulations is just starting. In addition, it is interesting to see what the role of carbon sequestration in the future will be.

Nurmon Bioenergia’s plan is to be the leading operator for development of new solutions for manure management in areas of intensive animal production. We want to be open for new technology innovations and will develop them by ourselves as well.

## 4.3 Profile of Competitors

In manure management and nutrient market, recycled nutrients are competing against traditional manure handling and inorganic fertilisers. This market is mainly cost-driven. In near future, no extra price can be achieved from food produced by recycled fertilisers, meaning farmers are not willing to pay extra. Consumers choose mainly the price, although

they could say that environmental issues are important. However, there is increasing interest for clean food, e.g., in Asian market. High quality food is just normal food for Finnish customers.

Bio-LNG market: Nurmon Bioenergia will be the biggest producer of bio-LNG in Finland after the plant being in full operation. However, the government owned gas company, Gasum Ltd, with a balance sheet total of € 1.527 M€ (2018) is a very big company compared to Nurmon Bioenergia and it is a very strong player as their main business is natural gas (single player in Finland so far). They are able to control the market and dictate the prices. More about Gasum is available at:

[https://www.gasum.com/globalassets/vuosiraportointi/raportit/2017/gasum\\_financialreview2017\\_en.pdf](https://www.gasum.com/globalassets/vuosiraportointi/raportit/2017/gasum_financialreview2017_en.pdf)

Gasum is also the biggest biogas producer in Finland. Their business, so far, is based on municipal and industrial waste treatment with gate fees, and a significant part of their feedstock is sewage sludge. Thus, they may have faced some challenges with digestate disposal and need to make some changes to their operational strategies as well as to invest in new technologies. Moreover, Gasum is mainly an energy company and has not been active in the agricultural sector so far. Thus, Nurmon Bioenergia has the possibility to become a market leader in biogas business relating to agricultural biomasses.

## 4.4 Competitive Advantage

Waste producers: Nurmon Bioenergia will be a flexible partner and provide service 24/7. The gate fees will be competitive due to the economy of scale and technical solutions of Nurmon Bioenergia's biogas plant concept. The company can also offer closed loop-co-operation, meaning energy and nutrients from own waste materials.

Farmer customers: main issue is to provide economically viable nutrient solution for plant production compared to inorganic fertilisers as well as for manure management. Nurmon Bioenergia's recycled nutrient products will be more efficient than raw manure in plant production and perform comparable or better than inorganic fertilisers, Nurmon will provide training services for ensuring the fertilising results. On request, the company will also provide contractors with the latest equipment for fertiliser application in the fields and will be the most knowledgeable operator in this sector.

## 4.5 Benefits to Clients

Bio-LNG customers: Unique product, limited availability so far. Only the first ones could achieve the green image benefits.

Farmers: Clean, organic fertilising products with similar performance as mineral fertilisers plus organic carbon for soil health and professional advice from experts.

# 5 Marketing/Sales Strategy

## 5.1 Marketing Strategy

In Qu1 and Qu2 a market survey among potential agricultural raw material producers and nutrient products end-users has been conducted. It turned out that the interest in both groups, suppliers and nutrient end-users, is very high.

Currently, the uptake potential of Nurmon Bioenergia for manure is about 400 000 tons (the current permit covers 240 000 tons) and the annual nutrient use potential of farmers in the region is more than 200 000 tons. The figures will be visualised and mapped in June. The study represents the first step for selecting suppliers and customers which will be followed by negotiations and pre-agreements.

More critical to the business case are energy sales/off-take contracts. Contracts covering at least 80% of the forecasted energy production is a pre-requisite to get the final go-ahead for the project including funding. After having secured the energy off-take contract, the final investment decision will follow, and building will start. A pre-agreement with a bio-LNG off-take company has already been signed.

## 5.2 Revenue Sources (NRR)

The key revenue source is the sales contract for upgraded biogas to be sold in the form of liquefied biogas (bio-LNG). Currently, LNG is quite cheap in Finland (about 60 €/MWh) and the plant should achieve revenues of ~100 €/MWh.

According to the level of interest for digestate demonstrated by farmers during the market investigations, selling the food waste and manure (no sewage sludge) based, processed digestate should not constitute a serious problem. However, it will not generate a significant revenue flow either.

## 5.3 Sales Strategy

The energy related sales strategy focuses on signing one or more off-take contracts with Finnish bio-LNG distributors. Bio-LNG is considered the energy carrier with the highest revenue potential, needing only limited state intervention in the market.

### **The bio-LNG market in Finland**

The chances for success should be quite good due to Finnish renewable energy policies and considering the recent statement of the CEO of the envisaged bio-LNG customer GASUM:

*"In ten years from now, the majority of the energy used will be renewable, and biogas will already play a significant role in Finland's energy production. A full switch to clean energy will have taken place in Baltic Sea shipping as well as in delivery and heavy-duty road transport. Major progress will also have been made in hydrogen-to-gas conversion."*

The switch of heavy-duty vehicles to liquefied natural gas (LNG) or liquefied biogas (bio-LNG) will result in significant cuts in carbon dioxide, nitrogen dioxide, particulate and noise emissions from transport. Based on life cycle analysis, the use of conventional LNG reduces greenhouse gas emissions by up to 20% compared with fossil diesel.

LNG-powered heavy-duty vehicles provide the same performance and driving comfort as diesel models. With one refuelling, an LNG-powered vehicle can run up to 1,600 km. Several vehicle manufacturers in the Nordics, such as Iveco, Scania and Volvo Trucks, offer modern LNG-powered trucks.

LNG-fuelled trucks can also switch to 100% renewable liquefied biogas (bio-LNG) without significant investments. The feedstock from which biogas is manufactured varies from country to country. Gasum produces biogas in Finland from biodegradable waste generated by homes, retail outlets and industry and from municipal sewage sludge. Biogas produced by Gasum in Sweden is made from sewage sludge, agricultural side streams, such as cereal straw and husks.

Bio-LNG reduces greenhouse gas emissions by up to 85% when compared with fossil fuels and up to 200% when manure is used as a raw material.

Consequently, one can assume that the future market for bio-LNG offers good opportunities for sales contracts assuring profitable operations.

## 5.4 Pricing

The price for bio-LNG is key for the project – hence it must be maximized. Prices for recycled fertilisers cannot yet be estimated: potential users are interested but the question is if the interest will sustain prices that may be comparable to mineral fertilisers. For this reason, Nurmon Bioenergia does not yet fix prices for fertilisers and may accept cost covering contributions from farmers in the region.

## 5.5 Marketing and Communications Strategy

A-Farmers uses SYSTEMIC as a communication platform. In addition, the project is promoted in the region, among others, by presentation of the fertilising products and by emphasizing the environmental benefits of the project.

Due to the early stage of the project implementation, marketing is not yet in the focus of the operators' activities. Currently, obtaining the operating permits has priority.

# 6 Research and Development

## 6.1 Research and Development

Research and development at Nurmon Bioenergia focus on applied research of conversion of manure and industry by-products to biogas and its upgrade to bio-LNG for use as transport fuel for heavy good vehicles in Finland.

With regard to the recycled nutrients, Nurmon Bioenergia has performed field tests and comprehensive analyses of digestate and recovered products. The main target of the ongoing fertiliser related R&D activities is adapting the recycled products to the needs of farmers in the Seinäjoki region and producing a relatively dry, pollutant free, storable (due to short growing seasons storage is a major issue in Finland), nutrient balanced organic fertiliser.

In future, Nurmon Bioenergia is open to new development, demonstration and piloting projects concerning, e.g., nutrient recovery or CO<sub>2</sub>-utilisation and will provide possibilities for researchers and technology suppliers for testing technologies in the plant area.

## 6.2 Technical Partners

Nurmon Bioenergia Ltd is the investor and operator of A-Farmers biogas business. At the moment Nurmon Bioenergia is owned by Heikas Ltd (90%) and Atria Finland Ltd. (10%).

Shareholding of Nurmon Bioenergy could change and new owners may come in later. However, the aim is to keep the SME status of the company. Consequently, large companies should not hold more than 25% of the shares. A-Farmers Ltd. is a subsidiary of Atria Finland Ltd.

## 6.3 IP, Patents, Copyrights, Brands

No specific IP related measures are currently pursued.

## 7 Staffing and Operations

The current chairman of the board and project owner is Jyrki Heilä, project manager is Teija Paavola, currently performing the permitting process and negotiations with potential suppliers and customers. Jyrki and Teija will continue leading the team after starting operations.

Nurmon Bioenergia will need 4-5 technical persons for daily operations of the biogas and nutrient recycling plant. Currently, negotiations with one service company are ongoing about the nutrient products resale and distribution. Another option is that nutrients are directly sold to farmers, without intermediaries. In this case, at least one person is needed for these tasks who coordinates transports, contractors and advices end-users etc.

Nurmon Bioenergia will outsource certain professional service activities such as accounting and continue cooperation with research institutes and external expert groups.

Currently, Nurmon Bioenergia is not planning to have own transportation vehicles.



## 8 Investment and Funding

CAPEX of the plant is roughly 34,5 M€, the highest investment into a single SYSTEMIC biogas plant. Funding of the biogas plus nutrient recovery depends on a bankable business case. The business case is considered bankable, if an off-take contract for most of the projected bio-LNG production can be presented to Finnish banks. Nurmon Bioenergia definitely has a bankable business case as the figures in under point 8 demonstrate.

The currently considered EIB financing model may be an alternative to Finnish banks but the bankable business case as a pre-requisite to project finance would not be avoided. EIB project finance is not a tool for financing projects that are not viable financially and economically. Interest rates and conditions for EIB loans will vary according to specific project aspects such as currencies borrowed, amount, duration and timing of disbursement. EIB can offer fixed, revisable and convertible rates, allowing for a change of interest rate formula during the life of the loan at predetermined dates or during predefined periods.

Unfortunately, EIB recently has refused financing biogas plants with NRR. The argument was that biogas plants are typically relatively high risk and low financing volume. From our point of view, the argument does not hold true for Nurmon Bioenergia and the decision should be revisited.

# 9 Financial Data/Projections

## 9.1 Business Case with NRR

Table 9.1 Profit & Loss summary (2022, full operation) in EUR

A-Farmers / Nurmon Bioenergia	Revenues	Expenses	Balance
Substrates (feedstock)	1.010.000	652.400	357.600
Energy and Green Certificates	8.100.000	1.372.080	6.727.920
Product sales / savings			0
Consumables (chemicals, spare parts)		1.035.326	-1.035.326
Digestate & NRR product handling (storage, application)			0
Operations (personnel, overhead, maintenance, repair)		1.575.000	-1.575.000
Amortisation (10 years)		3.450.000	-3.450.000
	9.110.000	8.084.806	1.025.194
<b>EBITA (Earnings before interest, amortisation and tax)</b>		<b>4.475.194</b>	<b>EBITA Margin 49%</b>
<b>EBIT (Earnings before interest and tax)</b>		<b>1.025.194</b>	<b>EBIT Margin 11%</b>

## 9.2 Business Case without NRR

The planned biogas plant would not be feasible without nutrient recovery. The main problem would be digestate storage capacity: 150 000 – 200 000 m<sup>3</sup>/year almost corresponding to the total annual digestate production.

The estimated storage, transport and application cost of the produced digestate would amount to 875 000 to 1 750 000 €/year if one realistically assumes an average cost of 5 – 10 €/m<sup>3</sup>. CAPEX and OPEX savings could not compensate the excessive storage and application cost.

The net savings of nutrient recovery are estimated at 0.5 to 1 million €/year.

# 10 Business Case Analysis

Since the Nurmon Bioenergia SYSTEMIC outreach plant is not yet in operation, the P&L calculation is based on the forecast for 2022, the first year in full operation. Key revenue flows have been already confirmed by pre-contracts - required by shareholders and banks - with suppliers (feedstock) and customers (bio-LNG).

The business case of the biogas plant of Nurmon Bioenergia is driven by two factors: i) the good perspectives for bio-LNG (liquid biomethane) for heavy duty transportation in Finland with bio-LNG politically being considered as an adequate replacement for fossil fuels for long distance transport and ii) the abundant availability of organic feedstock from livestock farming and the food industries. Both factors are pillars of the business case, but bio-LNG is by far outweighing gate-fees from feedstock. Local livestock farmers supplying manure, covering close to 50% of the organic plant feed, do not pay gate-fees like in the Netherlands and other European regions where livestock density is still considerably higher than in the Seinäjoki region where the plant is located. However, food industry supplying by-products to the plant pays gate-fees and contributes almost 1 M€ to the revenues of the plant.

Bio-LNG contributes about 8 M€ and is the source for the profitability of the plant, despite the high CAPEX of about 10 M€ related to purification and liquefaction of the biogas. Already signed pre-contracts with energy customers confirm that the required price of some 90-100 € per MWh for bio-LNG is achievable. The pre-contracts provide the solid financial basis for the project.

The products from NRR are separated to a solid fertilising product fraction, N:P concentrate to be used as fertilising product or as nutrient carrier for (industrial) wastewater treatment plants and to water that is dischargeable to sewage plants. Currently, none of these products is considered to directly contribute to the revenues of the plant – operators cannot forecast a relevant price for the digestate-based products, even if the N:P concentrate is needed by pulp and paper mills. However, separating the liquid fraction and making it dischargeable is key to the commercial viability of the plant with estimated savings of 0.5–1.0 M€ per year compared to the EBIT of slightly above 1 M€ per year.

The Nurmon Bioenergia business case demonstrates the prevailing trends for biogas, at least in Nordic countries: production of liquid biomethane (bio-LNG) or compressed biomethane (bio-CNG) as renewable fuel for trucks operating in transnational or transcontinental transport, requiring extended autonomy of up to 1600 km per tank. Bio-LNG can replace diesel without causing any inconvenience for the logistics sector: using the existing infrastructure, essentially the same diesel engines and being able to drive long distances without tank stops. Comparable services by electric trucks are not yet available and possibly never will be. Biogas to bio-LNG conversion is more efficient than conversion to power and the commercial value of bio-LNG or bio-CNG is higher.

If all assumptions hold true, Nurmon Bioenergia will demonstrate a profitable, resilient, waste and industrial by-product based business case with a clear function in the future energy mix and an easy transition pathway, to which truck manufacturers like Iveco, Scania and Volvo have already adapted by offering bio-LNG trucks with the same performance as diesel trucks but with much lower GHG or even negative (for the manure derived bio-LNG fraction) impact.

In conclusion, Nurmon Bioenergia demonstrates an example for conversion of waste biomass to gas which seems to have the potential for several similar projects, at least in Nordic countries. However, the pathway taken by Nordic countries may serve as a good example for other European member states for efficient use of waste-based biofuels with low environmental impact. The transition from diesel to bio-LNG does not require high infrastructure investments and can be implemented right away – in several European Member States an almost adequate fuelling infrastructure already exists.



Systemic large-scale eco-innovation to advance circular economy and mineral recovery from organic waste in Europe

### Consortium

Wageningen University and Research (NL)  
AM Power (BE)  
Groot Zevert Vergisting B.V. (NL)  
Acqua & Sole S.r.l. (IT)  
RIKA Biofuels Development Ltd. (UK)  
GNS Gesellschaft für Nachhaltige Stoffnutzung mbH (DE)  
A-Farmers Ltd (FI)  
ICL Europe (NL)  
Nijhuis Water Technology (NL)  
Proman Management GmbH (AU)  
Ghent University (BE)  
Milano University (IT)  
Vlaams Coördinatiecentrum Mestverwerking (BE)  
European Biogas Association (BE)  
Rural Investment Support for Europe (BE)

### Project coordinator

Oscar F. Schoumans  
Oscar.Schoumans@wur.nl  
Wageningen Environmental Research  
The Netherlands

Project website: [www.systemicproject.eu](http://www.systemicproject.eu)



Horizon 2020

The SYSTEMIC project has received funding from the European Union's Horizon 2020 Framework Programme for Research and Innovation under Grant Agreement no. 730400